

TABLE OF CONTENTS

Note: This Table of Contents has been prepared for the convenience of those using this contract with the sole express purpose of locating quickly the information contained herein; and no claims shall arise due to omissions, additions, deletions, etc., as this Table of Contents shall not be considered part of the contract.

Table of Contents

CONTRACT TIME AND LIQUIDATED DAMAGES	6
NOTICE TO CONTRACTOR - TRAFFIC SIGNALS	7
NOTICE TO CONTRACTOR - CAMPAIGN CONTRIBUTION AND.....	10
SOLICITATION BAN	10
NOTICE TO CONTRACTOR - CODE OF ETHICS	13
NOTICE TO CONTRACTOR - GIFT CERTIFICATION DISCLOSURE.....	21
NOTICE TO CONTRACTOR – CAMPAIGN CONTRIBUTION CERTIFICATION.....	22
NOTICE TO CONTRACTOR - AFFIDAVIT REGARDING CONSULTING AGREEMENTS.....	22
NOTICE TO CONTRACTOR - ETHICS SUMMARY	22
NOTICE TO CONTRACTOR – CONTRACTOR TRAINING	23
REQUIREMENT FOR 10-HOUR OSHA CONSTRUCTION SAFETY AND	23
HEALTH COURSE	23
NOTICE TO CONTRACTOR - VOLUNTARY PARTNERING	24
NOTICE TO CONTRACTOR - REQUIREMENTS OF TITLE 49, CODE OF	25
FEDERAL REGULATIONS PART 26.....	25
NOTICE TO CONTRACTOR - CONNECTICUT DEPARTMENT OF.....	26
TRANSPORTATION DISCLAIMER.....	26
NOTICE TO CONTRACTOR - BIDRIGGING AND/OR FRAUDS	27
NOTICE TO CONTRACTOR - GORE AREAS.....	28
NOTICE TO CONTRACTOR - VEHICLE EMISSIONS	29
NOTICE TO CONTRACTOR - TRAFFIC DRUMS AND TRAFFIC CONES.....	31
NOTICE TO CONTRACTOR - NCHRP 350 REQ. FOR WORK ZONE	32
TRAFFIC CONTROL DEVICES	32
SECTION 1.02 – PROPOSAL REQUIREMENTS AND CONDITIONS	33
SECTION 1.03 - AWARD AND EXECUTION OF CONTRACT.....	34
SECTION 1.05 - CONTROL OF THE WORK.....	36
SECTION 1.06 CONTROL OF MATERIALS.....	37
SECTION 1.07 - LEGAL RELATIONS AND RESPONSIBILITIES	39
SECTION 1.08 - PROSECUTION AND PROGRESS	43
SECTION 10.00 - GENERAL CLAUSES FOR HIGHWAY	49
ILLUMINATION AND TRAFFIC SIGNAL PROJECTS.....	49
SECTION 12.00 – GENERAL CLAUSES FOR HIGHWAY SIGNING.....	50
SECTION 12.08 - SIGN FACE-SHEET ALUMINUM.....	52
SECTION M.04 - BITUMINOUS CONCRETE	53
D.B.E. SUBCONTRACTORS AND MATERIAL SUPPLIERS OR MANUFACTURERS.....	86
ITEM #0921001A - CONCRETE SIDEWALK.....	99
ITEM #0925101A - RELAY BRICK WALK.....	100
ITEM #0952001A – SELECTIVE CLEARING AND THINNING.....	101
ITEM #0970006A - TRAFFICPERSON (MUNICIPAL POLICE OFFICER)	102
ITEM #0970007A - TRAFFICPERSON (UNIFORMED FLAGGER)	102
ITEM #0971001A – MAINTENANCE AND PROTECTION OF TRAFFIC	106
ITEM #0980001A – CONSTRUCTION STAKING	136
ITEM #1008908A - CLEAN EXISTING CONDUIT	138
ITEM #1010052A – CAST IRON HANDHOLE COVER	139
ITEM #1010054A – CAST IRON HANDHOLE COVER – TYPE II	139
ITEM #1017032A - SERVICE (METERED)	140
ITEM #1101303A - POLE ANCHOR	142
ITEM #1105001A - 1 WAY, 1 SECTION SPAN WIRE TRAFFIC SIGNAL	143
ITEM #1105003A - 1 WAY, 3 SECTION SPAN WIRE TRAFFIC SIGNAL	143
ITEM #1105007A - 2 WAY, 3 SECTION SPAN WIRE TRAFFIC SIGNAL	143
ITEM #1105011A - 3 WAY, 3 SECTION SPAN WIRE TRAFFIC SIGNAL	143
ITEM #1105180A - 1 WAY, 1 SECTION BI-COLORED ARROW	143
ITEM #1105203A - 1 WAY, 3 SECTION POLE MOUNTED TRAFFIC SIGNAL	143
ITEM #1105303A - 1 WAY, 3 SECTION PEDESTAL MOUNTED TRAFFIC SIGNAL	143
ITEM #1106001A - 1 WAY PEDESTRIAN SIGNAL POLE MOUNTED.....	147
ITEM #1106003A - 1 WAY PEDESTRIAN SIGNAL PEDESTAL MOUNTED	147
ITEM #1106004A - 2 WAY PEDESTRIAN SIGNAL PEDESTAL MOUNTED	147

ITEM #1107007A - PEDESTRIAN PUSHBUTTON AND SIGN \ (PIEZO)	149
ITEM #1108115A - FULL ACTUATED CONTROLLER 8 PHASE.....	150
ITEM #1108207A - INSTALL STATE FURNISHED TRAFFIC	164
CONTROLLER AND CABINET	164
ITEM #1108645A - AUXILIARY TERMINATION CABINET	166
ITEM #1108722A - VEHICLE EMITTER.....	167
ITEM #1108724A - PHASE SELECTOR	167
ITEM #1112410A - DETECTOR (TYPE A)	167
ITEM #1112470A - PRE-EMPTION SYSTEM CHASSIS	167
ITEM #1113550A - DETECTOR CABLE (OPTICAL)	167
ITEM #1111401A - LOOP VEHICLE DETECTOR	173
ITEM #1111451A - LOOP DETECTOR SAWCUT	173
ITEM #1111470A - TIME CLOCK.....	178
ITEM #1113398A - CABLE CLOSURE (TYPE A)	179
ITEM #1113431A - #16 AWG, 6 TWISTED PAIR, COMMUNICATION	180
CABLE	180
ITEM #1114201A - AUXILIARY EQUIPMENT CABINET	182
ITEM #1118012A - REMOVAL AND/OR RELOCATION OF TRAFFIC.....	183
SIGNAL EQUIPMENT	183
ITEM #1118051A - TEMPORARY SIGNALIZATION (SITE NO. 1)	186
ITEM #1118052A - TEMPORARY SIGNALIZATION (SITE NO. 2)	186
ITEM #1118053A - TEMPORARY SIGNALIZATION (SITE NO. 3)	186
ITEM #1118054A - TEMPORARY SIGNALIZATION (SITE NO. 4)	186
ITEM #1118055A - TEMPORARY SIGNALIZATION (SITE NO. 5)	186
ITEM #1118056A - TEMPORARY SIGNALIZATION (SITE NO. 6)	186
ITEM #1118057A - TEMPORARY SIGNALIZATION (SITE NO. 7)	186
ITEM #1118058A - TEMPORARY SIGNALIZATION (SITE NO. 8)	186
ITEM #1118059A - TEMPORARY SIGNALIZATION (SITE NO. 9)	186
ITEM #1118060A - TEMPORARY SIGNALIZATION (SITE NO. 10)	186
ITEM #1118071A - TEMPORARY SIGNALIZATION (SITE NO. 11)	186
ITEM #1118072A - TEMPORARY SIGNALIZATION (SITE NO. 12)	186
ITEM #1118073A - TEMPORARY SIGNALIZATION (SITE NO. 13)	186
ITEM #1118074A - TEMPORARY SIGNALIZATION (SITE NO. 14)	186
ITEM #1118075A - TEMPORARY SIGNALIZATION (SITE NO. 15)	186
ITEM #1118301A - RELOCATE PRE-EMPTION SYSTEM (SITE NO. 1)	190
ITEM #1118304A - RELOCATE PRE-EMPTION SYSTEM (SITE NO. 4)	190
ITEM #1118305A - RELOCATE PRE-EMPTION SYSTEM (SITE NO. 5)	190
ITEM #1118307A - RELOCATE PRE-EMPTION SYSTEM (SITE NO. 7)	190
ITEM #1118308A - RELOCATE PRE-EMPTION SYSTEM (SITE NO. 8)	190
ITEM #1118309A - RELOCATE PRE-EMPTION SYSTEM (SITE NO. 9)	190
ITEM #1118310A - RELOCATE PRE-EMPTION SYSTEM (SITE NO. 10)	190
ITEM #1118313A - RELOCATE PRE-EMPTION SYSTEM (SITE NO. 13)	190
ITEM #1118314A - RELOCATE PRE-EMPTION SYSTEM (SITE NO. 14)	190
ITEM #1206013A - REMOVAL OF EXISTING SIGNING	194
ITEM #1220011A - CONSTRUCTION SIGNS - TYPE III REFLECTIVE.....	195
SHEETING	195

SUPPLEMENTAL SPECIFICATIONS TO THE STANDARD SPECIFICATIONS FORM 816

FHWA REQUIRED CONTRACT PROVISIONS

Form PR-1273 All Federal Aid Construction Contracts

STATE OF CONNECTICUT REQUIRED CONTRACT PROVISIONS

SUBSTITUTION OF SECURITIES FOR RETAINAGES ON STATE CONTRACTS AND SUBCONTRACTS

NONDISCRIMINATION

NONDISCRIMINATION (SEXUAL ORIENTATION)

RESIDENTS' PREFERENCE IN WORK ON OTHER PUBLIC FACILITIES

CONSTRUCTION, ALTERATION OR REPAIR OF PUBLIC WORKS PROJECTS BY THE STATE OR POLITICAL SUBDIVISION

LIMITATION ON AWARDING OF CONTRACTS

RATE OF WAGES FOR WORK ON STATE HIGHWAYS

ANNUAL ADJUSTMENTS TO PREVAILING WAGES

AWARDING OF CONTRACTS TO OCCUPATIONAL SAFETY AND HEALTH LAW VIOLATORS PROHIBITED

CONSTRUCTION SAFETY AND HEALTH STANDARDS

SERVICE OF PROCESS

AMERICANS WITH DISABILITIES ACT OF 1990

EXECUTIVE ORDER NO. THREE

EXECUTIVE ORDER 7C

EXECUTIVE ORDER 14

EXECUTIVE ORDER NO. 16 - VIOLENCE IN THE WORKPLACE PREVENTION

EXECUTIVE ORDER NO. SEVENTEEN - LISTING ALL EMPLOYMENT OPENINGS WITH THE CONNECTICUT STATE EMPLOYMENT SERVICE

EXECUTIVE ORDER NO. 17

EXECUTIVE ORDER NO. 18

CONNECTICUT REQUIRED EQUAL EMPLOYMENT OPPORTUNITY RESPONSIBILITIES

AFFIRMATIVE ACTION REQUIREMENTS A(76)

PRIVATIZED PUBLIC RECORDS

OVERSIGHT OF LARGE STATE CONTRACTS

CONSTRUCTION SAFETY AND HEALTH COURSE

HEALTH INSURANCE PORTABILITY AND ACCOUNTABILITY ACT OF 1996 (“HIPAA”)

ATTACHMENTS

STANDARD FEDERAL EQUAL EMPLOYMENT OPPORTUNITY CONSTRUCTION SPECIFICATION
(EXECUTIVE ORDER 11246)

CONTRACTOR’S EXEMPT PURCHASE CERTIFICATE

EXECUTIVE ORDER NO. THREE

EXECUTIVE ORDER NO. 14

EXECUTIVE ORDER NO. 16

EXECUTIVE ORDER NO. SEVENTEEN

EXECUTIVE ORDER NO. 17

EXECUTIVE ORDER NO. 18

CONNECTICUT REQUIRED EQUAL EMPLOYMENT OPPORTUNITY RESPONSIBILITIES

STATE AND FEDERAL WAGE SCHEDULE

AUGUST 24, 2011

STATE PROJECT NO. 173-403

INSTALLATION AND REVISION OF TRAFFIC CONTROL SIGNALS IN DISTRICT 3

Towns of :

Branford, Bridgeport, East Haven, Milford, North Haven,
Norwich, Stratford, Weston, West Haven Westport and Woodbridge

The State of Connecticut, Department of Transportation, Standard Specifications for Roads, Bridges and Incidental Construction, Form 816, 2004, as revised by the Supplemental Specifications dated July 2011 (otherwise referred to collectively as "ConnDOT Form 816") is hereby made part of this contract, as modified by the Special Provisions contained herein. . The State of Connecticut Department of Transportation's "Construction Contract Bidding and Award Manual" ("Manual"), May 14, 2010 edition or latest issue, is hereby made part of this contract. If the provisions of this Manual conflict with provisions of other Department documents (not including statutes or regulations), the provisions of the Manual will govern. The Manual is available upon request from the Transportation Manager of Contracts. The Special Provisions relate in particular to the Installation and Revision of Traffic Control Signals in District 3 in the Towns of Branford, Bridgeport, East Haven, Milford, North Haven, Norwich, Stratford, Weston, West Haven Westport and Woodbridge.

CONTRACT TIME AND LIQUIDATED DAMAGES

Three Hundred and Eighty Four (384) calendar days will be allowed for completion of the work on this project and the liquidated damages charge to apply will be One Thousand Six Hundred and Fifty Dollars (\$1,650.00) per calendar day.

NOTICE TO CONTRACTOR - TRAFFIC SIGNALS

The Contractor is hereby notified that certain conditions pertaining to the installation of new signals and maintenance of traffic signal operations are required when relevant, as part of this contract.

Qualified/Unqualified Workers

U.S. Department of Labor

Occupational Safety & Health Administration (OSHA) www.osha.gov

Part Number 1910

Part Title Occupational Safety & Health Administration

Subpart S

Subpart Title Electrical

Standard Number 1910.333

Title Selection and use of work practices

Completion of this project will require Contractor employees to be near overhead utility lines. All workers and their activities when near utility lines shall comply with the above OSHA regulations. In general, unqualified workers are not allowed within 10 feet of overhead, energized lines. It is the contractor's responsibility to ensure that workers in this area are qualified in accordance with OSHA regulations.

The electric distribution company is responsible to provide and install all necessary anchors and guy strands on utility poles. It is the Contractors responsibility to coordinate with the utility company to ensure proper placement of the anchor. The Contractor will also reimburse the utility company the full cost for the installation of the anchor and guy.

This project includes countdown pedestrian signals. The countdown display is allowed only during the flashing don't walk time of the pedestrian movement.

The Controller Unit (CU) shall conform to the 2008-2010 Functional Specifications for Traffic Control Equipment. The Functional Specifications require the CU meet NEMA Standard Publication No. TS2-1992 Type 2. The Functional Specifications are available on the Departments' web site, www.ct.gov/dot/.

Under Maintenance and Protection of Traffic (M&PT) and Temporary Signalization the Contractor is required to keep in operation the following: all vehicle and pedestrian signals including necessary support structures; all vehicle and pedestrian detection; the pre-emption system; and coordination to the master, if in a system.

Existing or new span poles or utility poles cannot be double loaded without proper guying.

The contractor will be held liable for all damage to existing equipment resulting from his or his subcontractor's actions.

Vehicle detection material such as loop detector sawcut, conduit, and lead-in cables that is damaged during construction shall be repaired or replaced within 24 hours unless the Engineer determines otherwise. Loop detector sawcut, cable, and conduit replacements will be paid for under the applicable contract item, as listed below:

- Trenching and Backfilling
- Conduit
- Loop detector Sawcut
- 2 Conductor No. 14 Cable.

A credit will be deducted from monies due the Contractor for all maintenance calls responded to by Department of Transportation personnel.

See standard, "TR-1111_01, Loop Vehicle Detector and Sawcut", sheet. The saw cut installation procedure has changed. When loops are installed in two or more adjacent lanes, the inside lane loops are set back 1 foot (0.3 m) to allow a straight cut from the corner of the curb.

Special provision for Item # 1111451A – LOOP DETECTOR SAW CUT has been revised to reflect the new requirements for loop sealant.

All existing traffic appurtenances, in particular steel span poles, controller cabinets and pedestals shall be removed from the proposed roadway prior to excavation. The Contractor shall work with the utility companies to either relocate or install all traffic signal appurtenances prior to the roadway reconstruction.

The Contractor must install permanent or temporary spans in conjunction with utility company relocations. He then must either install the new signal equipment and controller or relocate the existing equipment.

The 30 Day Test on traffic control equipment, as specified in Section 10.00, Article 10.00.10 - TESTS, will not begin until the items listed below are delivered to the Department of Transportation, Traffic Signal Lab in Rocky Hill.

- Four (4) sets of cabinet wiring diagrams. Leave one set in the controller cabinet.
- All spare load switches and flash relays.

The following notes apply to projects which include Optical or Siren Pre-emption:

- Pre-emption is to operate through the internal pre-emption of the signal controller.
- If not present in a controller cabinet the contractor shall install the following items:
 - Pre-emption disconnect switch.
 - Pre-emption termination panel with “D” harness.
 - Pre-emption test pushbuttons.
- Contractor must provide a chart, or print out of the program steps and settings.
- Detector locations are for illustration only. Exact locations shall be determined by the Manufacturer or his designated representative. Detector cables are to be installed continuous between each detector and the auxiliary equipment cabinet.

Mast arm assemblies and foundations have new specifications and are to be designed based on The AASHTO 2009 Standards. Refer to new Specifications and Typical Detail Sheets.

All Mast Arm mounted signs are to be fixed mounted. Method of mounting must be submitted to the Division of Traffic for approval prior to installation unless otherwise noted.

Prior to the start of fabrication of steel mast arm assemblies, the contractor shall, in the field, verify the location of the foundations, and establish and verify all elevations, dimensions, and longitudinal grades. The contractor shall submit a cross section for each mast arm assembly in accordance with the special provisions of Article 1.05.02, prior to the submission of the shop drawings.

The contractor is advised that signal appurtenances (mast arms, span poles, pedestals and controllers) when in or adjacent to sidewalks, shall be field located to provide a free path of not less than 3 ft. (0.9 meters).

S:\traffic\1406\signal specs\specs\NTC-1 (QC+PA+COUNTDOWN)-rev7-10.doc

NOTICE TO CONTRACTOR - CAMPAIGN CONTRIBUTION AND SOLICITATION BAN

For all State contracts as defined in P.A. 10-1 having a value in a calendar year of \$50,000 or more or a combination or series of such agreements or contracts having a value of \$100,000 or more, the authorized signatory to this agreement/contract expressly acknowledges receipt of the State Elections Enforcement Commission's Notice advising state contractors of state campaign contribution and solicitation prohibitions, and will inform its principals of the contents of the notice. The State Elections Enforcement Commission Notice titled "Notice to Executive Branch State Contractors and Prospective State Contractors of Campaign Contribution and Solicitation Limitations" is attached hereto and hereby made a part of this agreement/contract.

Notice to Executive Branch State Contractors and Prospective State Contractors of Campaign Contribution and Solicitation Limitations

This notice is provided under the authority of Connecticut General Statutes §9-612(g)(2), as amended by P.A. 10-1, and is for the purpose of informing state contractors and prospective state contractors of the following law (italicized words are defined on the reverse side of this page).

CAMPAIGN CONTRIBUTION AND SOLICITATION LIMITATIONS

No *state contractor, prospective state contractor, principal of a state contractor or principal of a prospective state contractor*, with regard to a *state contract or state contract solicitation* with or from a state agency in the executive branch or a quasi-public agency or a holder, or principal of a holder of a valid prequalification certificate, shall make a contribution to (i) an exploratory committee or candidate committee established by a candidate for nomination or election to the office of Governor, Lieutenant Governor, Attorney General, State Comptroller, Secretary of the State or State Treasurer, (ii) a political committee authorized to make contributions or expenditures to or for the benefit of such candidates, or (iii) a party committee (which includes town committees).

In addition, no holder or principal of a holder of a valid prequalification certificate, shall make a contribution to (i) an exploratory committee or candidate committee established by a candidate for nomination or election to the office of State senator or State representative, (ii) a political committee authorized to make contributions or expenditures to or for the benefit of such candidates, or (iii) a party committee.

On and after January 1, 2011, no state contractor, prospective state contractor, principal of a state contractor or principal of a prospective state contractor, with regard to a state contract or state contract solicitation with or from a state agency in the executive branch or a quasi-public agency or a holder, or principal of a holder of a valid prequalification certificate, shall **knowingly solicit** contributions from the state contractor's or prospective state contractor's employees or from a *subcontractor or principals of the subcontractor* on behalf of (i) an exploratory committee or candidate committee established by a candidate for nomination or election to the office of Governor, Lieutenant Governor, Attorney General, State Comptroller, Secretary of the State or State Treasurer, (ii) a political committee authorized to make contributions or expenditures to or for the benefit of such candidates, or (iii) a party committee.

DUTY TO INFORM

State contractors and prospective state contractors are required to inform their principals of the above prohibitions, as applicable, and the possible penalties and other consequences of any violation thereof.

PENALTIES FOR VIOLATIONS

Contributions or solicitations of contributions made in violation of the above prohibitions may result in the following civil and criminal penalties:

Civil penalties—Up to \$2,000 or twice the amount of the prohibited contribution, whichever is greater, against a principal or a contractor. Any state contractor or prospective state contractor which fails to make reasonable efforts to comply with the provisions requiring notice to its principals of these prohibitions and the possible consequences of their violations may also be subject to civil penalties of up to \$2,000 or twice the amount of the prohibited contributions made by their principals.

Criminal penalties—Any knowing and willful violation of the prohibition is a Class D felony, which may subject the violator to imprisonment of not more than 5 years, or not more than \$5,000 in fines, or both.

CONTRACT CONSEQUENCES

In the case of a state contractor, contributions made or solicited in violation of the above prohibitions may resulting the contract being voided.

In the case of a prospective state contractor, contributions made or solicited in violation of the above prohibitions shall result in the contract described in the state contract solicitation not being awarded to the prospective state contractor, unless the State Elections Enforcement Commission determines that mitigating circumstances exist concerning such violation.

The State shall not award any other state contract to anyone found in violation of the above prohibitions for a period of one year after the election for which such contribution is made or solicited, unless the State Elections Enforcement Commission determines that mitigating circumstances exist concerning such violation.

Additional information may be found on the website of the State Elections Enforcement Commission, www.ct.gov/seec. Click on the link to "Lobbyist/Contractor Limitations."

DEFINITIONS

“State contractor” means a person, business entity or nonprofit organization that enters into a state contract. Such person, business entity or nonprofit organization shall be deemed to be a state contractor until December thirty-first of the year in which such contract terminates. “State contractor” does not include a municipality or any other political subdivision of the state, including any entities or associations duly created by the municipality or political subdivision exclusively amongst themselves to further any purpose authorized by statute or charter, or an employee in the executive or legislative branch of state government or a quasi-public agency, whether in the classified or unclassified service and full or part-time, and only in such person's capacity as a state or quasi-public agency employee.

“Prospective state contractor” means a person, business entity or nonprofit organization that (i) submits a response to a state contract solicitation by the state, a state agency or a quasi-public agency, or a proposal in response to a request for proposals by the state, a state agency or a quasi-public agency, until the contract has been entered into, or (ii) holds a valid prequalification certificate issued by the Commissioner of Administrative Services under section 4a-100. “Prospective state contractor” does not include a municipality or any other political subdivision of the state, including any entities or associations duly created by the municipality or political subdivision exclusively amongst themselves to further any purpose authorized by statute or charter, or an employee in the executive or legislative branch of state government or a quasi-public agency, whether in the classified or unclassified service and full or part-time, and only in such person's capacity as a state or quasi-public agency employee.

“Principal of a state contractor or prospective state contractor” means (i) any individual who is a member of the board of directors of, or has an ownership interest of five per cent or more in, a state contractor or prospective state contractor, which is a business entity, except for an individual who is a member of the board of directors of a nonprofit organization, (ii) an individual who is employed by a state contractor or prospective state contractor, which is a business entity, as president, treasurer or executive vice president, (iii) an individual who is the chief executive officer of a state contractor or prospective state contractor, which is not a business entity, or if a state contractor or prospective state contractor has no such officer, then the officer who duly possesses comparable powers and duties, (iv) an officer or an employee of any state contractor or prospective state contractor who has *managerial or discretionary responsibilities with respect to a state contract*, (v) the spouse or a *dependent child* who is eighteen years of age or older of an individual described in this subparagraph, or (vi) a political committee established or controlled by an individual described in this subparagraph or the business entity or nonprofit organization that is the state contractor or prospective state contractor.

“State contract” means an agreement or contract with the state or any state agency or any quasi-public agency, let through a procurement process or otherwise, having a value of fifty thousand dollars or more, or a combination or series of such agreements or contracts having a value of one hundred thousand dollars or more in a calendar year, for (i) the rendition of services, (ii) the furnishing of any goods, material, supplies, equipment or any items of any kind, (iii) the construction, alteration or repair of any public building or public work, (iv) the acquisition, sale or lease of any land or building, (v) a licensing arrangement, or (vi) a grant, loan or loan guarantee. “State contract” does not include any agreement or contract with the state, any state agency or any quasi-public agency that is exclusively federally funded, an education loan, a loan to an individual for other than commercial purposes or any agreement or contract between the state or any state agency and the United States Department of the Navy or the United States Department of Defense.

“State contract solicitation” means a request by a state agency or quasi-public agency, in whatever form issued, including, but not limited to, an invitation to bid, request for proposals, request for information or request for quotes, inviting bids, quotes or other types of submittals, through a competitive procurement process or another process authorized by law waiving competitive procurement.

“Managerial or discretionary responsibilities with respect to a state contract” means having direct, extensive and substantive responsibilities with respect to the negotiation of the state contract and not peripheral, clerical or ministerial responsibilities.

“Dependent child” means a child residing in an individual's household who may legally be claimed as a dependent on the federal income tax of such individual.

“Solicit” means (A) requesting that a contribution be made, (B) participating in any fund-raising activities for a candidate committee, exploratory committee, political committee or party committee, including, but not limited to, forwarding tickets to potential contributors, receiving contributions for transmission to any such committee or bundling contributions, (C) serving as chairperson, treasurer or deputy treasurer of any such committee, or (D) establishing a political committee for the sole purpose of soliciting or receiving contributions for any committee. Solicit does not include: (i) making a contribution that is otherwise permitted by Chapter 155 of the Connecticut General Statutes; (ii) informing any person of a position taken by a candidate for public office or a public official, (iii) notifying the person of any activities of, or contact information for, any candidate for public office; or (iv) serving as a member in any party committee or as an officer of such committee that is not otherwise prohibited in this section.

“Subcontractor” means any person, business entity or nonprofit organization that contracts to perform part or all of the obligations of a state contractor's state contract. Such person, business entity or nonprofit organization shall be deemed to be a subcontractor until December thirty first of the year in which the subcontract terminates. “Subcontractor” does not include (i) a municipality or any other political subdivision of the state, including any entities or associations duly created by the municipality or political subdivision exclusively amongst themselves to further any purpose authorized by statute or charter, or (ii) an employee in the executive or legislative branch of state government or a quasi-public agency, whether in the classified or unclassified service and full or part-time, and only in such person's capacity as a state or quasi-public agency employee.

“Principal of a subcontractor” means (i) any individual who is a member of the board of directors of, or has an ownership interest of five per cent or more in, a subcontractor, which is a business entity, except for an individual who is a member of the board of directors of a nonprofit organization, (ii) an individual who is employed by a subcontractor, which is a business entity, as president, treasurer or executive vice president, (iii) an individual who is the chief executive officer of a subcontractor, which is not a business entity, or if a subcontractor has no such officer, then the officer who duly possesses comparable powers and duties, (iv) an officer or an employee of any subcontractor who has managerial or discretionary responsibilities with respect to a subcontract with a state contractor, (v) the spouse or a dependent child who is eighteen years of age or older of an individual described in this subparagraph, or (vi) a political committee established or controlled by an individual described in this subparagraph or the business entity or nonprofit organization that is the subcontractor.

NOTICE TO CONTRACTOR - CODE OF ETHICS

The Contractor shall comply with the provisions contained in Section 1-86e of the Connecticut General Statutes, which provides as follows:

- (a) No person hired by the state as a Contractor or independent contractor shall:
 - (1) Use the authority provided to the person under the contract, or any confidential information acquired in the performance of the contract, to obtain financial gain for the person, an employee of the person or a member of the immediate family of any such person or employee;
 - (2) Accept another state contract which would impair the independent judgment of the person in the performance of the existing contract; or
 - (3) Accept anything of value based on an understanding that the actions of the person on behalf of the state would be influenced.
- (b) No person shall give anything of value to a person hired by the state as a Contractor or independent contractor based on an understanding that the actions of the Contractor or independent contractor on behalf of the state would be influenced.

The following clause is applicable to those contracts with a value of five hundred thousand dollars (\$500,000) or more:

The Contractor shall comply with the Code of Ethics for Public Officials, Conn. Gen. Stat. §§ 1-79 *et seq.*, and Code of Ethics for Lobbyists, Conn. Gen. Stat. §§1-91 *et seq.*, when and where applicable. Insofar as state contractors are concerned, a summary of the most relevant provisions of the Codes of Ethics is contained in the Summary of State Ethics Laws for Current and Potential State Contractors. The Contractor acknowledges receiving such Summary, which is incorporated herein by reference. The Summary may change from time to time and may be accessed via the Internet at www.ethics.state.ct.us.

The Contractor agrees that the above clause will also be incorporated in all of its contracts with its subcontractors and consultants.

The Contractor agrees that any instance of its violating the Code of Ethics or the Department of Transportation Ethics Policy will be sufficient cause for the Department to terminate any or all of the Contractor's pending contracts with the Department.

In addition, the Contractor hereby acknowledges and agrees to comply with the policies enumerated in "Connecticut Department of Transportation Policy Statement Policy No. F&A-10, Subject: Code of Ethics Policy", dated June 1, 2007, a copy of which is attached hereto and made a part hereof.



CONNECTICUT DEPARTMENT OF TRANSPORTATION POLICY STATEMENT

POLICY NO. F&A-10
June 1, 2007

SUBJECT: Code of Ethics Policy

The purpose of this policy is to establish and maintain high standards of honesty, integrity, and quality of performance for all employees of the Department of Transportation ("DOT" or "Department"). Individuals in government service have positions of significant trust and responsibility that require them to adhere to the highest ethical standards. Standards that might be acceptable in other public or private organizations are not necessarily acceptable for the DOT.

It is expected that all DOT employees will comply with this policy as well as the Code of Ethics for Public Officials, and strive to avoid even the appearance of impropriety in their relationships with members of the public, other agencies, private vendors, consultants, and contractors. This policy is, as is permitted by law, in some cases stricter than the Code of Ethics for Public Officials. Where that is true, employees are required to comply with the more stringent DOT policy.

The Code of Ethics for Public Officials is State law and governs the conduct of all State employees and public officials regardless of the agency in which they serve. The entire Code, as well as a summary of its provisions, may be found at the Office of State Ethics' web site: www.ct.gov/ethics/site/default.asp. For formal and informal interpretations of the Code of Ethics, DOT employees should contact the Office of State Ethics or the DOT's Ethics Compliance Officer or her designee.

All State agencies are required by law to have an ethics policy statement. Additionally, all State agencies are required by law to have an Ethics Liaison or Ethics Compliance Officer. The DOT, because of the size and scope of its procurement activities, has an Ethics Compliance Officer who is responsible for the Department's: development of ethics policies; coordination of ethics training programs; and monitoring of programs for agency compliance with its ethics policies and the Code of Ethics for Public Officials. At least annually, the Ethics Compliance Officer shall provide ethics training to agency personnel involved in contractor selection, evaluation, and supervision. A DOT employee who has a question or is unsure about the provisions of this policy, or who would like assistance contacting the Office of State Ethics, should contact the Ethics Compliance Officer or her designee.

The DOT Ethics Compliance Officer is:

Denise Rodosevich, Managing Attorney
Office of Legal Services

**For questions, contact the Ethics
Compliance Officer's Designee:**

Alice M. Sexton, Principal Attorney
Office of Legal Services
2800 Berlin Turnpike
Newington, CT 06131-7546
Tel. (860) 594-3045

To contact the Office of State Ethics:

Office of State Ethics
20 Trinity Street, Suite 205
Hartford, CT 06106
Tel. (860) 566-4472
Facs. (860) 566-3806
Web: www.ethics.state.ct.us

Enforcement

The Department expects that all employees will comply with all laws and policies regarding ethical conduct. Violations of the law may subject an employee to sanctions from agencies or authorities outside the DOT. Whether or not another agency or authority imposes such sanctions, the Department retains the independent right to review and respond to any ethics violation or alleged ethics violation by its employees. Violations of this policy or ethics statutes, as construed by the DOT, may result in disciplinary action up to and including dismissal from State service.

Prohibited Activities

1. ***Gifts:*** DOT employees (and in some cases their family members) are prohibited by the Code of Ethics and this Policy from accepting a gift from anyone who is: (1) doing business with, or seeking to do business with, the DOT; (2) directly regulated by the DOT; (3) prequalified as a contractor pursuant to Conn. Gen. Stat. §4a-100 by the Commissioner of the Department of Administrative Services (DAS); or (4) known to be a registered lobbyist or a lobbyist's representative. These four categories of people/entities are referred to as "restricted donors." A list of registered lobbyists can be found on the web site of the Office of State Ethics (www.ct.gov/ethics/site/default.asp). A list of prequalified consultants and contractors, *i.e.*, those seeking to do business with the DOT, can be found on the DOT's Internet site under "Consultant Information" and "Doing Business with ConnDOT," respectively.

The term "gift" is defined in the Code of Ethics for Public Officials, Conn. Gen. Stat. §1-79(e), and has numerous exceptions. For example, one exception permits the acceptance of food and/or beverages valued up to \$50 per calendar year from any one donor and consumed on an occasion or occasions while the person paying or his representative is present. Therefore, such food and/or beverage is not a "gift." Another exception permits the acceptance of items having a value up to ten dollars (\$10) provided the aggregate value of all things provided by the donor to the recipient during a calendar year does not exceed fifty dollars (\$50). Therefore, such items are not a "gift." Depending on the circumstances, the "donor" may be an individual if the individual is bearing the expense, or a donor may be the individual's employer/group if the individual is passing the expense back to the employer/group he/she represents.

This policy requires DOT employees to immediately return any gift (as defined in the Code of Ethics) that any person or entity attempts to give to the employee(s). If any such gift or other item of value is received by other than personal delivery from the subject person or entity, the item shall be taken to the Office of Human Resources along with the name and address of the person or entity who gave the item. The Office of Human Resources, along with the recipient of the item of value, will arrange for the donation of the item to a local charity (e.g., Foodshare, local soup kitchens, etc.). The Office of Human Resources will then send a letter to the gift's donor advising the person of the item's donation to charity and requesting that no such gifts be given to DOT employees in the future.

2. ***Contracting for Goods or Services for Personal Use With Department Contractors, Consultants, or Vendors:*** Executive Order 7C provides that: "Appointed officials and state employees in the Executive Branch are prohibited from contracting for goods and services, for personal use, with any person doing business with or seeking business with his or her agency, unless the goods or services are readily available to the general public for the price which the official or state employee paid or would pay."

3. **Gift Exchanges Between Subordinates and Supervisors/Senior Staff:** A recent change in the Code of Ethics prohibits exchanges of gifts valued at \$100 or more between (*i.e.*, to and from) supervisors and employees under their supervision. The Citizen's Ethics Advisory Board has advised that: (1) the monetary limit imposed by this provision is a per-gift amount; (2) gifts given between supervisors and subordinates (or *vice versa*) in celebration of a "major life event," as defined in the Code of Ethics, need not comply with the \$100 limit; and (3) the limitations imposed by this provision apply to a direct supervisor and subordinate *and to any individual up or down the chain of command*. The Citizen's Ethics Advisory Board has also advised that supervisors or subordinates may not pool their money to give a collective or group gift valued at \$100 or more, even though each of the individual contributions is less than \$100.
4. **Acceptance of Gifts to the State:** A recent change to the Code of Ethics for Public Officials modified the definition of the term "gift" to limit the application of the so-called "gift to the State" exception. In general, "gifts to the State" are goods or services given to a State agency for use on State property or to support an event and which facilitate State action or functions. Before accepting any benefit as a "gift to the State," DOT employees should contact the Ethics Compliance Officer.
5. **Charitable Organizations and Events:** No DOT employee shall knowingly accept any gift, discount, or other item of monetary value for the benefit of a charitable organization from any person or entity seeking official action from, doing or seeking business with, or conducting activities regulated by, the Department.
6. **Use of Office/Position for Financial Gain:** DOT employees shall not use their public office, position, or influence from holding their State office/position, nor any information gained in the course of their State duties, for private financial gain (or the prevention of financial loss) for themselves, any family member, any member of their household, nor any "business with which they are associated." In general, a business with which one is associated includes any entity of which a DOT employee or his/her immediate family member is a director, owner, limited or general partner, beneficiary of a trust, holder of 5 percent or more stock, or an officer (president, treasurer, or executive or senior vice president).

DOT employees shall not use or distribute State information (except as permitted by the Freedom of Information Act), nor use State time, personnel, equipment, or materials, for other than State business purposes.

7. **Other Employment:** DOT employees shall not engage in, nor accept, other employment that will either impair their independence of judgment with regard to their State duties or require or induce them to disclose confidential information gained through their State duties.

Any DOT employee who engages in or accepts other employment (including as an independent contractor), or has direct ownership in an outside business or sole proprietorship, shall complete an Employment/Outside Business Disclosure Form (see attached) and submit it to the Department's Human Resources Administrator. Disclosure of other employment to the DOT Human Resources Administrator shall *not* constitute approval of the other employment for purposes of the Code of Ethics for Public Officials.

Inquiries concerning the propriety of a DOT employee's other employment shall be directed to the Office of State Ethics to assure compliance with the Code of Ethics for Public Officials. Employees anticipating accepting other employment as described above should give ample time (at least one month) to the Office of State Ethics to respond to such outside employment inquiries.

No employee of the DOT shall allow any private obligation of employment or enterprise to take precedence over his/her responsibility to the Department.

8. **Outside Business Interests:** Any DOT employee who holds, directly or indirectly, a financial interest in any business, firm, or enterprise shall complete an Employment/Outside Business Disclosure Form (see attached) and submit it to the Department's Human Resources Administrator. An indirect financial interest includes situations where a DOT employee's spouse has a financial interest in a business, firm, or enterprise. A financial interest means that the employee or his spouse is an owner, member, partner, or shareholder in a non-publicly traded entity. Disclosure of such outside business interests to the DOT Human Resources Administrator shall *not* constitute approval of the outside business interest under this Policy or the Code of Ethics for Public Officials. DOT employees shall not have a financial interest in any business, firm, or enterprise which will either impair their independence of judgment with regard to their State duties or require or induce them to disclose confidential information gained through their State duties. Inquiries concerning the propriety of a DOT employee's outside business interests shall be directed to the Office of State Ethics to assure compliance with the Code of Ethics for Public Officials.
9. **Contracts With the State:** DOT employees, their immediate family members, and/or a business with which a DOT employee is associated, may not enter into a contract with the State, other than pursuant to a court appointment, valued at \$100 or more unless the contract has been awarded through an open and public process.
10. **Sanctioning Another Person's Ethics Violation:** No DOT official or employee shall counsel, authorize, or otherwise sanction action that violates any provision of the Code of Ethics.
11. **Certain Persons Have an Obligation to Report Ethics Violations:** If the DOT Commissioner, Deputy Commissioner, or "person in charge of State agency procurement" and contracting has reasonable cause to believe that a person has violated the Code of Ethics or any law or regulation concerning ethics in State contracting, he/she *must* report such belief to the Office of State Ethics. All DOT employees are encouraged to disclose waste, fraud, abuse, and corruption about which they become aware to the appropriate authority (see also Policy Statement EX.O.-23 dated March 31, 2004), including, but not limited to, their immediate supervisor or a superior of their immediate supervisor, the DOT Office of Management Services, the Ethics Compliance Officer, the Auditors of Public Accounts, the Office of the Attorney General, or the Office of the Chief State's Attorney.
12. **Post-State Employment Restrictions:** In addition to the above-stated policies of the Department, DOT employees are advised that the Code of Ethics for Public Officials bars certain conduct by State employees *after they leave State service. Upon leaving State service:*
 - **Confidential Information:** DOT employees must never disclose or use confidential information gained in State service for the financial benefit of any person.
 - **Prohibited Representation:** DOT employees must *never* represent anyone (other than the State) concerning any "particular matter" in which they participated personally and substantially while in State service and in which the State has a substantial interest.

DOT employees also must not, for one year after leaving State service, represent anyone other than the State for compensation before the DOT concerning a matter in which the State has a substantial interest. In this context, the term "represent" has been very broadly defined. Therefore, any former DOT employee contemplating post-State employment work that might involve interaction with any bureau of DOT (or any Board or Commission administratively under the DOT) within

their first year after leaving State employment should contact the DOT Ethics Compliance Officer and/or the Office of State Ethics.

- **Employment With State Vendors:** DOT employees who participated substantially in, or supervised, the negotiation or award of a State contract valued at \$50,000 or more must not accept employment with a party to the contract (other than the State) for a period of one year after resigning from State service, if the resignation occurs within one year after the contract was signed.

13. **Ethical Considerations Concerning Bidding and State Contracts:** DOT employees also should be aware of various provisions of Part IV of the Code of Ethics that affect any person or firm who: (1) is, or is seeking to be, prequalified by DAS under Conn. Gen. Stat. §4a-100; (2) is a party to a large State construction or procurement contract, or seeking to enter into such a contract, with a State agency; or (3) is a party to a consultant services contract, or seeking to enter into such a contract, with a State agency. These persons or firms shall not:

- With the intent to obtain a competitive advantage over other bidders, solicit any information from an employee or official that the contractor knows is not and will not be available to other bidders for a large State construction or procurement contract that the contractor is seeking;
- Intentionally, willfully, or with reckless disregard for the truth, charge a State agency for work not performed or goods not provided, including submitting meritless change orders in bad faith with the sole intention of increasing the contract price, as well as falsifying invoices or bills or charging unreasonable and unsubstantiated rates for services or goods to a State agency; and
- Intentionally or willfully violate or attempt to circumvent State competitive bidding and ethics laws.

Firms or persons that violate the above provisions may be deemed a nonresponsible bidder by the DOT.

In addition, no person with whom a State agency has contracted to provide consulting services to plan specifications for any contract, and no business with which such person is associated, may serve as a consultant to any person seeking to obtain such contract, serve as a contractor for such contract, or serve as a subcontractor or consultant to the person awarded such contract.

DOT employees who believe that a contractor or consultant may be in violation of any of these provisions should bring it to the attention of their manager.

Training for DOT Employees

A copy of this policy will be posted throughout the Department, and provided to each employee either in hard copy or by e-mail. As set forth above, State law requires that certain employees involved in contractor/consultant/vendor selection, evaluation, or supervision must undergo annual ethics training coordinated or provided by the Ethics Compliance Officer. If you believe your duties meet these criteria, you should notify your Bureau Chief to facilitate compilation of a training schedule. In addition, the DOT Ethics Compliance Officer can arrange for periodic ethics training provided by the Office of State Ethics. Finally, the Department will make available, on its web site or otherwise, a copy of this policy to all vendors, contractors, and other business entities doing business with the Department.

Important Ethics Reference Materials

It is strongly recommended that every DOT employee read and review the following:

- Code of Ethics for Public Officials, Chapter 10, Part 1, Conn. General Statutes Sections 1-79 through 1-89a found at: www.ct.gov/ethics/site/default.asp
- Ethics Regulations Sections 1-81-14 through 1-81-38, found at: www.ct.gov/ethics/site/default.asp
- The Office of State Ethics web site includes summaries and the full text of formal ethics advisory opinions interpreting the Code of Ethics, as well as summaries of previous enforcement actions: www.ct.gov/ethics/site/default.asp. DOT employees are strongly encouraged to contact the Department's Ethics Compliance Officer or her designee, or the Office of State Ethics with any questions or concerns they may have.

(This Policy Statement supersedes Policy Statement No. F&A-10 dated January 6, 2006)

Ralph J. Carpenter
COMMISSIONER

Attachment

List 1 and List 3

(Managers and supervisors are requested to distribute a copy of this Policy Statement to all employees under their supervision.)

cc: Office of the Governor, Department of Administrative Services, Office of State Ethics

Department of Transportation Employment & Outside Business Disclosure Form

In accordance with Department of Transportation (Department) Policy Statement No. F&A-10, Code of Ethics Policy, I am hereby advising the Department that in addition to my current DOT position, I have other employment and/or a direct or indirect financial interest in an outside business as follows:

1. Full name of outside employer, or entity in which I or my spouse have a financial interest (e.g., ownership or member/partner): _____

2. Location of Employer/Entity disclosed above: _____

3. Nature of my/my spouse's relationship to employer/entity disclosed above (check at least one):

- Employee or Independent Contractor (circle one)
- Owner/Member/Partner/etc.
- Family Member of Owner/Member/Partner/etc.

4. State agency(ies) with which above employer/entity is doing business or seeking Business (write "N/A" if not applicable): _____

5. Job Title at Outside Employer: _____

6. Job Responsibilities at Outside Employer: _____

7. Current State Title: _____

8. Current State Job Responsibilities: _____

9. Name/Title of Current State Supervisor: _____

I understand that the filing of this Disclosure with the DOT Human Resources Administrator does not relieve me of any obligations I have to comply with the Code of Ethics for Public Officials, and does not constitute approval of my outside employment and/or financial interests under the Code of Ethics for Public Officials. *Employees engaging in outside employment are strongly urged to seek written approval of their outside employment from the Office of State Ethics, 20 Trinity Street, Hartford, CT 06106.* I also understand that if either my State or outside employment/financial interest changes in location or function I am required to notify the Department immediately.

Signed: _____
Printed Name: _____

Date: _____

NOTICE TO CONTRACTOR - GIFT CERTIFICATION DISCLOSURE

Pursuant to Connecticut General Statutes, Section 4-252 and Executive Order No. 7C, paragraph 10, the Contractor is notified of subsections (c) and (d) of this Section as follows. The Contractor must incorporate the planning date indicated below under subsection (e) on Certification Form 1, at the time the Contract is executed.

(c) The official of the person, firm or corporation awarded the contract, who is authorized to execute the contract, shall certify on such form as the State shall provide the following:

(1) That no gifts were made between the date that the state agency or quasi-public agency began planning the project, services, procurement, lease or licensing arrangement covered by the contract and the date of execution of the contract, by (A) such person, firm, corporation, (B) any principals and key personnel of the person, firm or corporation, who participated substantially in preparing the bid or proposal or the negotiation of the contract, or (C) any agent of such person, firm, corporation or principals and key personnel, who participated substantially in preparing the bid or proposal or the negotiation of the contract, to (i) any public official or state employee of the state agency or quasi-public agency soliciting bids or proposals for the contract, who participated substantially in the preparation of the bid solicitation or request for proposals for the contract or negotiation or award of the contract, or (ii) any public official or state employee of any other state agency, who has supervisory or appointing authority over such state agency or quasi-public agency;

(2) That no such principals and key personnel of the person, firm or corporation, or agent of such person, firm or corporation or principals and key personnel, knows of any action by the person, firm or corporation to circumvent such prohibition on gifts by providing for any other principals and key personnel, official, employee or agent of the person, firm or corporation to provide a gift to any such public official or state employee; and

(3) That the person, firm or corporation made the bid or proposal without fraud or collusion with any person.

(d) Any bidder or proposer that does not make the certifications required under subsection (c) of this section shall be disqualified and the state agency or quasi-public agency shall award the contract to the next highest ranked proposer or the next lowest responsible qualified bidder or seek new bids or proposals.

(e) The date that the Department of Transportation began planning the project, services, procurement, lease or licensing arrangement to be covered by this contract is **July 13, 2011**.

NOTICE TO CONTRACTOR – CAMPAIGN CONTRIBUTION CERTIFICATION

A certification of campaign contribution to accompany State Contracts with a value of \$50,000 or more in a calendar or fiscal year, pursuant to Conn. Gen. Stat. §4-250 and Executive Orders No. I, paragraph 8 and No. 7C, paragraph 10, must be completed on the form provided by the Department of Transportation (DOT); and such certification shall cover the two year period preceding the execution of the contract. Each principal of a joint venture, if any, must submit a separate certification. The Department of Transportation will not accept a bid for a large state construction or procurement contract without such certification.

NOTICE TO CONTRACTOR - AFFIDAVIT REGARDING CONSULTING AGREEMENTS

The "Affidavit Regarding Consulting Agreements" must be completed and should be submitted in response to such a request for procurement or solicitation for those contracts having an anticipated total value to the State of more than fifty thousand dollars (\$50,000) in a calendar or fiscal year. Contractors will not be selected if the required Affidavit is not submitted.

This Affidavit is attached to all bid proposals when issued to prospective bidders. Bidders are responsible for the submission of this Affidavit.

NOTICE TO CONTRACTOR - ETHICS SUMMARY

The current "Acknowledgment of Receipt of Summary of State Ethics Laws" must be completed by you and should be submitted with your bid for any large state construction or procurement contract as defined in Section 32 of Public Act 05-287. The Department of Transportation will not accept a bid for a large state construction or procurement contract without such Acknowledgment.

In addition, if you are awarded such a contract, you will be required to obtain from your sub-contractors and consultants a fully and properly executed copy of the attached "Subcontractor and/or Consultant Acknowledgment of Receipt of Summary of State Ethics Laws," and to submit said copies to the initiating unit.

**NOTICE TO CONTRACTOR – CONTRACTOR TRAINING
REQUIREMENT FOR 10-HOUR OSHA CONSTRUCTION SAFETY AND
HEALTH COURSE**

In accordance with Connecticut General Statute 31-53b and Public Act No. 08-83, the Contractor is required to furnish proof that any person performing the work of a mechanic, laborer or worker pursuant to the classifications of labor under section 31-53, has completed a course of at least ten hours in duration in construction safety and health approved by the Federal Occupational Safety and Health Administration or, has completed a new miner training program approved by the Federal Mine Safety and Health Administration in accordance with 30 CFR 48 or, in the case of telecommunications employees, has completed at least ten hours of training in accordance with 29 CFR 1910.268.

Proof of compliance with the provisions of the statute shall consist of a student course completion card issued by the federal Occupational Safety and Health Administration, or other such proof as deemed appropriate by the Commissioner of the Connecticut Department of Labor, dated no earlier than five years prior to the commencement of the project. Each employer shall affix a copy of the construction safety course completion card for each applicable employee to the first certified payroll submitted to the Department of Transportation on which the employee's name first appears.

Any employee required to complete a construction safety and health course as required that has not completed the course, shall have a maximum of fourteen (14) days to complete the course. If the employee has not been brought into compliance, they shall be removed from the project until such time as they have completed the required training.

This section does not apply to employees of public service companies, as defined in section 16-1 of the 2008 supplement to the General Statutes, or drivers of commercial motor vehicles driving the vehicle on the public works project and delivering or picking up cargo from public works projects provided they perform no labor relating to the project other than the loading and unloading of their cargo.

The internet website for the federal Occupational Safety and Health Training Institute is <http://www.osha.gov/fso/ote/training/edcenters>.

Additional information regarding this statute can be found at the Connecticut Department of Labor website, <http://www.ctdol.state.ct.us/wgwkstnd/wgemenu.htm>.

Any costs associated with this notice shall be included in the general cost of the contract. In addition, there shall be no time granted to the contractor for compliance with this notice. The contractor's compliance with this notice and any associated regulations shall not be grounds for claims as outlined in Section 1.11 – "Claims".

NOTICE TO CONTRACTOR - VOLUNTARY PARTNERING

The Connecticut Department of Transportation (ConnDOT) intends to encourage the foundation of a cohesive partnership with the Contractor and its principal subcontractors on this project. This partnership will be structured to draw on the strengths of each organization to identify and achieve reciprocal goals. The objectives are effective and efficient contract performance and completion within budget, on schedule, and in accordance with plans and specifications.

This partnership will be bilateral in makeup, and participation will be totally voluntary. Any cost associated with effectuating this partnering will be agreed to by both parties and will be shared equally.

To implement this partner initiative, the Contractor and ConnDOT will meet and plan a partnering development seminar/team building workshop. At this planning session arrangements will be made to determine attendees at the workshop, agenda of the workshop, duration and location. Persons required to be in attendance will be the ConnDOT District Engineer and key project personnel, the Contractor's on-site project manager and key supervision personnel of both the prime and principal subcontractors. The project design engineers and key local government personnel will also be required to have Regional/District and Corporate/State level managers on the project team.

Follow-up workshops will be held periodically throughout the duration of the Contract as agreed by the Contractor and ConnDOT.

The establishment of a partnership charter on a project will not change the legal relationship of the parties to the Contract nor relieve either party from any of the terms of the Contract.

ConnDOT and the Contractor will jointly select a facilitator to conduct the partnering workshops. The Contractor will obtain the services of the chosen facilitator and ConnDOT will reimburse the Contractor for fifty percent (50%) of the costs agreed to between ConnDOT and the Contractor.

NOTICE TO CONTRACTOR - REQUIREMENTS OF TITLE 49, CODE OF FEDERAL REGULATIONS PART 26

The contractor, subrecipient or subcontractor shall not discriminate on the basis of race, color, national origin, or sex in the performance of this contract. The contractor shall carry out applicable requirements of 49 CFR Part 26 in the award and administration of DOT-assisted contracts. Failure by the contractor to carry out these requirements is a material breach of this contract, which may result in the termination of this contract or such other remedy as the recipient deems appropriate.

**NOTICE TO CONTRACTOR - CONNECTICUT DEPARTMENT OF
TRANSPORTATION DISCLAIMER**

Connecticut Department of Transportation bidding and other information and documents which are obtained through the Internet, World Wide Web Sites or other sources are not to be construed to be official information for the purposes of bidding or conducting other business with the Department.

It is the responsibility of each bidder and all other interested parties to obtain all bidding related information and documents from official sources within the Department.

Persons and/or entities which reproduce and/or make such information available by any means are not authorized by the Department to do so and may be liable for claims resulting from the dissemination of unofficial, incomplete and/or inaccurate information.

NOTICE TO CONTRACTOR - BIDRIGGING AND/OR FRAUDS

The Connecticut Department of Transportation is cooperating with the U.S. Department of Transportation and the Justice Department in their investigation into highway construction contract bidrigging and/or frauds.

A toll-free "HOT LINE" telephone number 800-424-9071 has been established to receive information from contractors, subcontractors, manufacturers, suppliers or anyone with knowledge of bidrigging and/or frauds either past or current. The "HOT LINE" telephone number will be manned during normal working hours (8 A.M. - 5 P.M. EST.), and information will be treated confidentially and anonymity respected.

NOTICE TO CONTRACTOR - GORE AREAS

Gore areas will no longer be available for disposal of surplus material.

NOTICE TO CONTRACTOR - VEHICLE EMISSIONS

All motor vehicles and/or construction equipment (both on-highway and non-road) shall comply with all pertinent State and Federal regulations relative to exhaust emission controls and safety.

The contractor shall establish staging zones for vehicles that are waiting to load or unload at the contract area. Such zones shall be located where the emissions from the vehicles will have minimum impact on abutters and the general public.

Idling of delivery and/or dump trucks, or other equipment shall not be permitted during periods of non-active use, and it should be limited to three minutes in accordance with the Regulations of Connecticut State Agencies Section 22a-174-18(b)(3)(c):

No mobile source engine shall be allowed “to operate for more than three (3) consecutive minutes when the mobile source is not in motion, except as follows:

- (i) When a mobile source is forced to remain motionless because of traffic conditions or mechanical difficulties over which the operator has no control,
- (ii) When it is necessary to operate defrosting, heating or cooling equipment to ensure the safety or health of the driver or passengers,
- (iii) When it is necessary to operate auxiliary equipment that is located in or on the mobile source to accomplish the intended use of the mobile source,
- (iv) To bring the mobile source to the manufacturer’s recommended operating temperature,
- (v) When the outdoor temperature is below twenty degrees Fahrenheit (20 degrees F),
- (vi) When the mobile source is undergoing maintenance that requires such mobile source be operated for more than three (3) consecutive minutes, or
- (vii) When a mobile source is in queue to be inspected by U.S. military personnel prior to gaining access to a U.S. military installation.”

All work shall be conducted to ensure that no harmful effects are caused to adjacent sensitive receptors. Sensitive receptors include but are not limited to hospitals, schools, daycare facilities, elderly housing and convalescent facilities. Engine exhaust shall be located away from fresh air intakes, air conditioners, and windows.

A Vehicle Emissions Mitigation plan will be required for areas where extensive work will be performed in close proximity (less than 50 feet (15 meters)) to sensitive receptors. No work will proceed until a sequence of construction and a Vehicle Emissions Mitigation plan is submitted in writing to the Engineer for review and all comments are addressed prior to the commencement of any extensive construction work in close proximity (less than 50 feet (15 meters)) to sensitive receptors. The mitigation plan must address the control of vehicle emissions from all vehicles and construction equipment.

If any equipment is found to be in non-compliance with this specification, the contractor will be issued a Notice of Non-Compliance and given a 24 hour period in which to bring the equipment into compliance or remove it from the project. If the contractor then does not comply, the Engineer shall withhold all payments for the work performed on any item(s) on which the non-conforming equipment was utilized for the time period in which the equipment was out of compliance.

Any costs associated with this "Vehicle Emissions" notice shall be included in the general cost of the contract. In addition, there shall be no time granted to the contractor for compliance with this notice. The contractor's compliance with this notice and any associated regulations shall not be grounds for claims as outlined in Section 1.11 – "Claims".

NOTICE TO CONTRACTOR - TRAFFIC DRUMS AND TRAFFIC CONES

Traffic Drums and 42-inch (1 m) Traffic Cones shall have four six-inch (150 mm) wide stripes (two - white and two - orange) of flexible bright fluorescent sheeting.

The material for the stripes shall be one of the following, or approved equal:

- 3M Scotchlite Diamond Grade Flexible Work Zone Sheeting, Model 3910 for the white stripes and Model 3914 for the orange stripes,
- Avery Dennison WR-7100 Series Reboundable Prismatic Sheeting, Model WR-7100 for the white stripes and Model WR-7114 for the orange stripes.

NOTICE TO CONTRACTOR - NCHRP 350 REQ. FOR WORK ZONE TRAFFIC CONTROL DEVICES

CATEGORY 1 DEVICES (traffic cones, traffic drums, tubular markers, flexible delineator posts)

Prior to using the Category 1 Devices on the project, the Contractor shall submit to the Engineer a copy of the manufacturer's self-certification that the devices conform to NCHRP Report 350.

CATEGORY 2 DEVICES (construction barricades, construction signs and portable sign supports)

Prior to using Category 2 Devices on the project, the Contractor shall submit to the Engineer a copy of the Letter of Acceptance issued by the FHWA to the manufacturer documenting that the devices (both sign and portable support tested together) conform to NCHRP Report 350 (TL-3).

Specific requirements for these devices are included in the Special Provisions.

Information regarding NCHRP Report 350 devices may be found at the following web sites:

FHWA: http://safety.fhwa.dot.gov/roadway_dept/road_hardware/index.htm

ATSSA: <http://www.atssa.com/resources/NCHRP350Crashtesting.asp>

NOTE: The portable wooden sign supports that have been traditionally used by most contractors in the State of Connecticut do NOT meet NCHRP Report 350 criteria and shall not be utilized on any project advertised after October 01, 2000.

CATEGORY 3 DEVICES (Truck-Mounted Attenuators & Work Zone Crash Cushions)

Prior to using Category 3 Devices on the project, the Contractor shall submit to the Engineer a copy of the Letter of Acceptance issued by the FHWA to the manufacturer documenting that the devices conform to NCHRP Report 350.

SECTION 1.02 – PROPOSAL REQUIREMENTS AND CONDITIONS

Article 1.02.04 – Examination of Plans, Specifications, Special Provisions and Site of Work:

Replace the third sentence of the last paragraph with:

The Department cannot ensure a response to inquiries received later than ten (10) days prior to the original scheduled opening of the related bid.

SECTION 1.03 - AWARD AND EXECUTION OF CONTRACT

Article 1.03.07 – Insurance:

The first paragraph is revised as follows:

Before the Contract is executed, the Contractor must file with the Commissioner a certificate of insurance, fully executed by an insurance company or companies satisfactory to the Commissioner, on a form **acceptable to** the Department, for the insurance policy or policies required below, which policy or policies shall be in accordance with the terms of said Certificate of Insurance. Continuance of the required insurance during the entire term of the Contract shall be the responsibility of the Contractor and is a condition of the Contract.

Add the following after the second paragraph:

The Contractor shall produce, within five (5) business days, a copy or copies of all applicable insurance policies when requested by the State. In providing said policies, the Contractor may redact provisions of the policy that are proprietary. This provision shall survive the suspension, expiration or termination of this Contract.

Replace the like named paragraph with the following:

4. Owner’s and Contractor’s Protective Liability Insurance for and in the Name of the State:

With respect to the Contractor’s Project operations and also those of its subcontractors, the Contractor shall carry, for and on behalf of the State, insurance which shall provide coverage of at least \$1,000,000 for each accident or occurrence resulting in damages from (1) bodily injury to or death of persons and/or (2) injury to or destruction of property. Subject to that limit per accident or occurrence, the policy shall provide an aggregate coverage of at least \$2,000,000 for all pertinent damages arising during the policy period.

Delete subsections 8, 9 and 10 and replace them with the following:

8. Compensation:

There shall be no direct compensation allowed the Contractor on account of any premium or other charge necessary to obtain and keep in effect any insurance or bonds in connection with the Project, but the cost thereof shall be considered included in the general cost of the Project work.

9. Protection and Indemnity Insurance for Marine Construction Operations in Navigable Waters:

If a vessel of any kind will be involved in Project work, the Contractor shall obtain the following additional insurance coverage:

A. Protection and Indemnity Coverage of at least \$300,000 per vessel or equal to at least the value of hull and machinery, whichever is greater.

B. If there is any limitation or exclusion with regard to crew and employees under the protection and indemnity form, the Contractor must obtain and keep in effect throughout the Project a workers' compensation policy, including coverage for operations under admiralty jurisdiction, with a limit of liability of at least \$300,000 per accident or a limit equal to at least the value of the hull and machinery, whichever is greater, or for any amount otherwise required by statute.

SECTION 1.05 - CONTROL OF THE WORK

Article 1.05.02 - Plans, Working Drawings and Shop Drawings
is supplemented as follows:

Subarticle 1.05.02 - (2) is supplemented by the following:

When required by the contract documents or when ordered by the Engineer, The Contractor shall prepare and submit nine (9) sets of catalog cuts and or shop drawings for all traffic signal items to the Division of Traffic for approval before fabrication.

Please forward to:

Lisa N. Conroy, P.E.
Transportation Supervising Engineer
Connecticut Department of Transportation
Division of Traffic Engineering – Electrical
2800 Berlin Turnpike
P.O. Box 317546
Newington, Connecticut 06131-7546
(860) 594-2985

SECTION 1.06 CONTROL OF MATERIALS

Article 1.06.01 - Source of Supply and Quality:

Add the following:

For the following items the contractor shall submit a complete description of the item, with nine (9) copies of shop drawings, cuts and other descriptive literature which completely illustrates such items presented for formal approval. Such approval shall not change the requirements for a certified test report and materials certificate as may be called for. All shop drawings shall be submitted at one time.

Steel Span Poles
Aluminum Pedestals
Traffic Signals
Flasher Cabinet
LED Traffic Signal Lamp Unit
Pedestrian Signals
Pedestrian Pushbuttons and Signs
Controller
 Solid State Time Switch
 Solid State Load Switch
 Conflict Monitor
 Solid State Flasher
Auxiliary Termination Cabinet

Pre-Emption Equipment
 Vehicle Emitter
 Phase Selector
 Detector (Type)
 Pre-Emption System Chassis
Detector Cable (Optical)
Vehicle Detectors
Loop Sawcut Sealant
Time Clock
Communication Cable
Cable Closure
Auxiliary Equipment Cabinet

Article 1.06.07 - Certified Test Reports and Materials Certificate.

1) For the materials in the following items, a Certified Test Report will be required confirming their conformance to the requirements set forth in these plans or specifications or both. Should the consignee noted on a Certified Test Report be other than the Prime Contractor, then Materials Certificates shall be required to identify the shipment.

Steel Span Pole Anchor Bolts
Steel Span Poles

2) For the materials in the following items, a Materials Certificate will be required confirming their conformance to the requirements set forth in these plans or specifications or both.

Steel Span Poles
Aluminum Pedestals
Traffic Signals
Flasher Cabinet
LED Traffic Signal Lamp Unit
Pedestrian Signals
Pedestrian Pushbuttons and Signs
Controller
 Solid State Time Switch
 Solid State Load Switch
 Conflict Monitor
 Solid State Flasher
Auxiliary Termination Cabinet
Pre-Emption Equipment
 Vehicle Emitter
 Phase Selector
 Detector (Type)
 Pre-Emption System Chassis
Detector Cable (Optical)
Vehicle Detectors
Loop Sawcut Sealant
Time Clock
Communication Cable
Cable Closure
Auxiliary Equipment Cabinet

s:\traffic\1406\signal specs\specs\1.06-GENERAL REQUIREMENTS

SECTION 1.07 - LEGAL RELATIONS AND RESPONSIBILITIES

Article 1.07.13 - Contractor's Responsibility for Adjacent Property, Facilities and Services is supplemented as follows:

The following company and representative shall be contacted by the Contractor to coordinate the protection of their utilities on this project 30 days prior to the start of any work on this project involving their utilities:

Mr. Gerard McDonald
District 3 Electrical Supervisor
Department of Transportation
Milford, Connecticut
(203) 882-2033

Northeast Utilities

Mr. John Sochi
Westport
(203) 845-3432

Mr. Jeff Bexter
Norwalk
(203) 845-3469

Mr. Rich Mather
Weston
(203) 845-3487

Mr. Tony Sarubbi
Branford
(203) 245-5412

United Illuminating

Mr. Dominic Yacobino
Bridgeport, Milford, E. Haven & N. Haven
(203) 499-5977

Mr. Thomas Judge
Stratford, Woodbridge, W. Haven
(203) 926-4772

AT&T

Mr. Michael Brecher
(203) 238-5201

S:/1406/signal specs/specs/1.07-LEGAL RELATIONS & RESPONSIBILITY

SECTION 1.07 - LEGAL RELATIONS AND RESPONSIBILITIES

Article 1.07.05 - Load Restrictions:

Delete all three paragraphs and replace them with the following:

“(a) Vehicle Weights: This sub article will apply to travel both on existing pavements and pavements under construction. The Contractor shall comply with all legal load restrictions as to vehicle size, the gross weight of vehicles, and the axle weight of vehicles while hauling materials. Throughout the duration of the contract, the Contractor shall take precautions to ensure existing and newly installed roadway structures and appurtenances are not damaged by construction vehicles or operations.

Unless otherwise noted in contract specifications or plans, on and off road equipment of the Contractor, either loaded or unloaded, will not be allowed to travel across any bridge or on any highway when such a vehicle exceeds the statutory limit or posted limit of such bridge or highway. Should such movement of equipment become necessary the Contractor shall apply for a permit from the Department for such travel, as provided in the Connecticut General Statutes (CGS). The movement of any such vehicles within the project limits or detour routes shall be submitted to the Engineer for project record. Such permit or submittal will not excuse the Contractor from liability for damage to the highway caused by its equipment.

The Contractor is subject to fines, assessments and other penalties that may be levied as a result of violations by its employees or agents of the legal restrictions as to vehicle size and weight.

(b) Storage of Construction Materials/Equipment on Structures: Storage is determined to be non-operating equipment or material. The Contractor shall not exceed the statutory limit or posted limit for either an existing or new structure when storing materials and/or construction equipment. When a structure is not posted, then the maximum weight of equipment or material stored in each 12 foot wide travel lane of any given span shall be limited to 750 pounds per linear foot combined with a 20,000 pound concentrated load located anywhere within the subject lane. If anticipated storage of equipment or material exceeds the above provision, then the Contractor shall submit his proposal of storage supported by calculations stamped by a Professional Engineer registered in the State of Connecticut, to the Engineer for approval 14 days prior to the storage operation. Operations related to structural steel demolition or erection shall follow the guidelines under Section 6.03. All other submittals shall include a detailed description of the material/equipment to be stored, the quantity of storage if it is stockpiled materials, the storage location, gross weight with supporting calculations if applicable, anticipated duration of storage, and any environmental safety, or traffic protection that may be required. Storage location on the structure shall be clearly defined in the field. If structures are in a state of staged construction or demolition, additional structural analysis may be required prior to authorization of storage.”

Article 1.07.10 - Contractor's Duty to Indemnify the State against Claims for Injury or Damage:

Add the following after the only paragraph:

“It is further understood and agreed by the parties hereto, that the Contractor shall not use the defense of Sovereign Immunity in the adjustment of claims or in the defense of any suit, including any suit between the State and the Contractor, unless requested to do so by the State.”

Article 1.07.13 - Contractor's Responsibility for Adjacent Property, Facilities and Services is supplemented as follows:

The following company and representative shall be contacted by the Contractor to coordinate the protection of their utilities on this project 30 days prior to the start of any work on this project involving their utilities:

Mr. Gerard McDonald
District 3 Electrical Supervisor
Department of Transportation
Milford, Connecticut
(203) 882-2033

Northeast Utilities

Mr. John Sochi
Westport
(203) 845-3432

Mr. Jeff Bexter
Norwalk
(203) 845-3469

Mr. Rich Mather
Weston
(203) 845-3487

Mr. Tony Sarubbi
Branford
(203) 245-5412

United Illuminating

Mr. Dominic Yacobino
Bridgeport, Milford, E. Haven & N. Haven
(203) 499-5977

Mr. Thomas Judge
Stratford, Woodbridge, W. Haven
(203) 926-4772

AT&T

Mr. Michael Brecher
(203) 238-5201

S:/1406(signal specs)\specs\1.07-LEGAL RELATIONS & RESPONSIBILITY

SECTION 1.08 - PROSECUTION AND PROGRESS

Article 1.08.01 – Transfer of Work or Contract: *Add the following after the last paragraph:*

The Contractor shall pay the subcontractor for work performed within thirty (30) days after the Contractor receives payment for the work performed by the subcontractor. Also, any retained monies on a subcontractor's work shall be paid to the subcontractor within thirty (30) days after satisfactory completion of all the subcontractor's work.

For the purpose of this Item, satisfactory completion shall have been accomplished when:

- (1) The subcontractor has fulfilled the contract requirements of both the Department and the subcontract for the subcontracted work, including the completion of any specified material and equipment testing requirement or plant establishment period and the submission of all submittals (i.e.: certified payrolls, material samples and certifications, required state and federal submissions, etc.) required by the specifications and the Department, and
- (2) The work done by the subcontractor has been inspected and approved by the Department and the final quantities of the subcontractor's work have been determined and agreed upon.

If the Contractor determines that a subcontractor's work is not complete, the Contractor shall notify the subcontractor and the Engineer, in writing, of the reasons why the subcontractor's work is not complete. This written notification shall be provided to the subcontractor and the Engineer within twenty-one (21) days of the subcontractor's request for release of retainage.

The Engineer will institute administrative procedures to expedite the determination of final quantities for the subcontractor's satisfactorily completed work.

The inspection and approval of a subcontractor's work does not eliminate the Contractor's responsibilities for all the work as defined in Article 1.07.12, "Contractor's Responsibility for Work."

The inspection and approval of the subcontractor's work does not release the subcontractor from its responsibility for maintenance and other periods of subcontractor responsibility specified for the subcontractor's items of work. Failure of a subcontractor to meet its maintenance, warranty and/or defective work responsibilities may result in a finding that the subcontractor is non-responsible on future subcontract assignments.

For any dispute regarding prompt payment or release of retainage, the alternate dispute resolution provisions of this article shall apply.

The above requirements are also applicable to all sub-tier subcontractors and the above provisions shall be made a part of all subcontract agreements.

Failure of the Contractor to comply with the provisions of this section may result in a finding that the Contractor is non-responsible on future projects.

Article 1.08.03 - Prosecution of Work:

Add the following:

The project will be constructed in various phases as described herein.

Phase 1 – Organization Phase up to (168) Calendar Days.

The first phase is to afford the Contractor time for the administrative/engineering/procurement function required for the project. This would include such items as performing construction staking, digging test pits, submitting catalog cuts or shop drawings and purchasing materials. Actual construction is not permitted during the period. The Contractor is to use this time to fully prepare for the successive phases so that construction can proceed quickly and efficiently. During the phase, after the construction staking is complete and underground utilities are marked out the Contractor, the designer and the Engineer will walk the project to determine if there are test pits necessary or if there are any apparent conflicts with private property, utilities, or other roadside appurtenances such as obstructions, rocks, large trees, etc. Those conflicts will be resolved prior to ordering equipment for the specific area where the conflict exists. Calendar days for this phase will run through the winter shutdown (December 1 through March 31 of the following year).

Phase 2 – Construction Phase – (216) Calendar Days

When all apparent conflicts have been identified and resolved, and written commitments have been received from suppliers that all equipment and materials will be received within 30 days, the Contractor may request that the construction phase begin. Once commencement of construction begins, as and when approved by the Engineer, the Contractor will have (216) consecutive calendar days to complete the work, including cleanup. That work, once started, must be completed within the time established for the original construction phase, and liquidated damages, as specified elsewhere in the Contract, will be assessed against the Contractor per calendar day from that day until the date on which the work is complete. If unforeseen situations arise, the Contractor may request an extension of time for an individual location and, if justified, the Engineer may grant an extension of time for that location. Granting an extension of time for one location will not entitle the Contractor to extensions of time for other locations in the project.

Phase 2 will not start prior to the conclusion of Phase 1. If Phase 1 is completed during the winter period Phase 2 will begin on the following April 1. The Contractor may begin Phase 2 only with prior written permission from the Engineer to do so, unless all the work allotted for this phase can be completed prior to the winter period. If the project will not be completed in the one construction season, the contractor shall complete all work started at or between intersections, including cleanup, prior to the winter shutdown.

New Work

Additional work, including work at a separate location, may be added to the contract in accordance with Article 1.04.05 of the Standard Specifications. This work may result in a contract extension, which would require an organization phase and a construction phase for the new location. If a contract extension is granted for the additional work, liquidated damages for this portion of the work will be negotiated with the Contractor. Such an extension of time would not affect the time allowed for the original work in the contract. Original work, once started must be completed within the original construction phase, and liquidated damages will be assessed for any days beyond that phase which the Contractor takes to complete the original work.

s:\traffic\1406\signal specs\specs\1.08.03- prosecution of work.doc

Article 1.08.04 - Limitation of Operations - Add the following:

TIME RESTRICTIONS

In order to provide for traffic operations as outlined in the Special Provision "Maintenance and Protection of Traffic," the Contractor will not be allowed to perform any work that will interfere with existing traffic operations on all project roadways as follows:

On the following State observed Legal Holidays:

New Year's Day
Good Friday, Easter*
Memorial Day
Independence Day
Labor Day
Columbus Day
Thanksgiving Day**
Christmas Day

The following restrictions also apply:

On the day before and the day after any of the above Legal Holidays.

On the Friday, Saturday and Sunday immediately preceding any of the above Holidays celebrated on a Monday.

On the Saturday, Sunday and Monday immediately following any of the above Holidays celebrated on a Friday.

* From 6:00 a.m. the Thursday before the Holiday to 8:00 p.m. the Monday after the Holiday.

** From 6:00 a.m. the Wednesday before the Holiday to 8:00 p.m. the Monday after the Holiday.

STATE/TOWN ROADS

The Contractor will not be allowed to perform any work that will interfere with the existing number of lanes of traffic, including turning lanes at intersections, on:

Monday through Friday between 6:00 a.m. and 9:00 a.m.
and between 3:00 p.m. and 7:00 p.m.

LANE CLOSURE RESTRICTIONS

It is anticipated that work on adjacent projects may be ongoing simultaneously with this project. The Contractor shall be aware of those projects so that coordination is maintained for proper traffic flow at all times on all project roadways and this coordination is acceptable to the Engineer.

The Contractor will not be allowed to close a lane if a Contractor working on an adjacent project has the opposite lane closed unless there is at least a one mile clear area length where the entire roadway is open to traffic, measured from the end of the first work area to the beginning of the signing pattern for the next work area.

OTHER LIMITATIONS

The field installation of a signing pattern shall constitute interference with existing traffic operations and shall not be allowed except during the allowable periods.

No roadway, with the exception of transition areas, shall be open to traffic unless the appropriate pavement markings have been installed. The transition areas shall have pavement markings applied immediately upon opening to traffic.

Replace 1.08.13 – “Termination of the Contractor's Responsibility” with the following:

1.08.13 - Acceptance of Work and Termination of the Contractor's Responsibility:

The Contractor's responsibility for non-administrative Project work will be considered terminated when the final inspection has been held, any required additional work and final cleaning-up have been completed, all final operation and maintenance manuals have been submitted, and all of the Contractor's equipment and construction signs have been removed from the Project site. When these requirements have been met to the satisfaction of the Engineer, the Commissioner will accept the work by certifying in writing to the Contractor, that the non-administrative Project work has been satisfactorily completed.

**SECTION 10.00 - GENERAL CLAUSES FOR HIGHWAY
ILLUMINATION AND TRAFFIC SIGNAL PROJECTS**

Article 10.00.12 - Negotiations with utility company: Add the following:

The contractor shall give notice to utility companies a minimum of 30 days prior to required work or services to the utility company. The following list of utility companies and representatives may be used for the convenience of the contractor.

Mr. Gerard McDonald
District 3 Electrical Supervisor
Department of Transportation
Milford, Connecticut
(203) 882-2033

Northeast Utilities

Mr. John Sochi
Westport
(203) 845-3432

Mr. Jeff Bexter
Norwalk
(203) 845-3469

Mr. Rich Mather
Weston
(203) 845-3487

Mr. Tony Sarubbi
Branford
(203) 245-5412

United Illuminating

Mr. Dominic Yacobino
Bridgeport, Milford, E. Haven & N. Haven
(203) 499-5977

Mr. Thomas Judge
Stratford, Woodbridge, W. Haven
(203) 926-4772

AT&T

Mr. Michael Brecher
(203) 238-5201

All work shall be in conformance with Rules and Regulations of PUCA concerning Traffic Signals attached to Public Service Company Poles. The Contractor is cautioned that there may be energized wires in the vicinity of the specified installations. In addition to ensuring compliance with NESC and OSHA regulations, the Contractor and/or its Sub-Contractors should coordinate with the appropriate utility company for securing/protecting the site during the installation of traffic signal mast arms, span poles or illumination poles.

SECTION 12.00 – GENERAL CLAUSES FOR HIGHWAY SIGNING

Description:

Work under this item shall conform to the requirements of Section 12.00 supplemented as follows:

12.00.06 – Data Labels:

For the purpose of developing and maintaining a highway sign inventory and for the purpose of sampling and testing reflective sheeting, the Contractor shall affix a Data Label(s) to the back of each sign face-extruded aluminum sign and each sign face-sheet aluminum sign in the vicinity of the lower left hand corner or quadrant. Data Labels shall be 2 (two) separate 5 (five) inch by 3 (three) inch, non-reflective weatherproof films with black copy on a yellow background having a pressure sensitive adhesive backing.

A “Fabrication” Data Label is to include information about the sign fabricator, date of fabrication and the sheeting manufacturer - type. An “Installation” Data Label is to include The State Project Number or Maintenance Permit Number that installed the sign and date of installation.

The cost of the data labels coded and in place on the sign shall be included in the unit cost of the respective sign material. Payment for the respective quantities of each sign face-extruded aluminum sign and each sign face-sheet aluminum sign may be withheld until all Data Label(s) have been installed to the satisfaction of the Engineer.

The Data Label designs, with additional notes relative to design requirements are attached herewith.

DATA LABELS

NON REFLECTIVE, WEATHERPROOF FILM
BLACK COPY, YELLOW BACKGROUND

CONN DOT											
SIGN FACE DATA LABEL											
Fabricator: (Insert NAME or State)											
Sheeting Manufacturer - Type (Insert NAME - TYPE)											
Date Fabricated - Month / Year											
J	F	M	A	M	J	J	A	S	O	N	D
11	12	13	14	15	16	17	18	19	20	21	22

CONN DOT											
SIGN FACE DATA LABEL											
Installed By											
Project No: (Insert 000-0000 or State)											
Permit No: (Insert D_-000000)											
Date Installed - Month / Year											
J	F	M	A	M	J	J	A	S	O	N	D
11	12	13	14	15	16	17	18	19	20	21	22

Data Labels To Be 5 Inch By 3 inch Each, With Face Designs As Shown Above.
All Copy Ink Must Be Durable And Not Fade, Discolor or Smudge.
All Variable Legends To Be Included At Label Fabrication.
Only One "Installed By" Permit or Project Number, Should Be Provided
Sign Fabrication and / or Installation by State Forces, Insert "State"
The Month And Year Of Fabrication And Installation;
May Be Punched Or Marked Out.

The Back Of The Data Label Must Contain A Precoated
Pressure-Sensitive Adhesive Covered By A Removable Liner.
At Application, The Liner Must Be Removable Without Soaking In
Water Or Other Solvents.
The Adhesive Must Form A Durable Bond To Surfaces That Are
Smooth, Clean, Corrosion-Free and Weather Resistant.

Completed Data Labels Must Not Discolor, Crack, Craze, Blister,
Delaminate, Peel, Chalk, Or Lose Adhesion When Subjected
To Temperatures From -30 Degrees To 200 Degrees Fahrenheit.

SECTION 12.08 - SIGN FACE-SHEET ALUMINUM

Work under this item shall conform to the requirements of Section 12.08 amended as follows:

General: Delete all references to parapet mounted sign supports.

Article M.18.15 – Sign Mounting Bolts: *Replace with the following:*

Bolts used for sign mounting shall be stainless steel and conform to ASTM F593, Group 1 or 2 (Alloy Types 304 or 316). Locking nuts shall be stainless steel and shall conform to ASTM F594 (Alloy Types 304 or 316). Washers shall also be stainless steel and shall conform to ASTM A240 (Alloy Types 304 or 316).

SECTION M.04 - BITUMINOUS CONCRETE

M.04.01—Bituminous Concrete Materials and Facilities

M.04.02—Mix Design and Job Mix Formula (JMF)

M.04.03—Production Quality Control (QC) Testing and Control of Mixture

M.04.01—Bituminous Concrete Materials and Facilities: Each source of material, and facility used to produce and test bituminous concrete (HMA) must be qualified on an annual basis by the Engineer. The basis of approval for plant machinery, material processing & controls, and field laboratory requirements are available from the Engineer. Test Procedures and Specifications referenced herein are in accordance with the latest AASHTO and ASTM Standard Test Procedures and Specifications. Such references when noted with an (M) have been modified by the Engineer and are detailed in Table M.04.03-6.

The Contractor shall submit to the Engineer all sources of coarse aggregate, fine aggregate, mineral filler and PG binder. The Contractor shall submit a Material Safety Data Sheet (MSDS) for each grade of binder to be used on the Project. The Contractor shall not change material sources without prior approval of the Engineer.

An adequate quantity of each size aggregate, mineral filler and bitumen shall be maintained at the HMA plant site at all times while the plant is in operation to ensure that the plant can consistently produce bituminous concrete mixtures that meet the job mix formula (JMF) as specified in Article M.04.02. The quantity of such material shall be reviewed by the Engineer on an individual plant basis and is dependent upon the plant's daily production capacity, but shall never be less than one day's production capacity. Less than one day's production capacity may be cause for the job mix formula to be rejected.

1. Coarse Aggregate:

- a. **Requirements:** The coarse aggregate shall consist of clean, hard, tough, durable fragments of crushed stone or crushed gravel of uniform quality. Aggregates from multiple sources of supply must not be mixed or stored in the same stockpile.
- b. **Basis of Approval:** The request for approval of the source of supply shall include a washed sieve analysis in accordance with AASHTO T 27. The G_{sa} , G_{sb} , and P_{wa} shall be determined in accordance with AASHTO T 85. The coarse aggregate must not contain more than 1% crusher dust, sand, soft disintegrated pieces, mud, dirt, organic and other injurious materials. When tested for abrasion using AASHTO T 96, the aggregate loss must not exceed 40%. When tested for soundness using AASHTO T 104 with a magnesium sulfate solution, the coarse aggregate must not have a loss exceeding 10% at the end of 5 cycles.

For HMA mixtures, materials shall also meet the coarse aggregate angularity criteria as specified in Tables M.04.02-2 thru M.04.02-4 for blended aggregates retained on the #4 sieve when tested according to ASTM D 5821. The amount of aggregate particles of the

coarse aggregate blend retained on the #4 sieve that are flat or elongated shall be determined in accordance with ASTM D 4791 and shall not exceed 10% by weight when tested to a 3:1 ratio, as shown in Tables M.04.02-2 thru M.04.02-4.

2. Fine Aggregate:

Requirements: The fine aggregate from each source quarry/pit deposit shall consist of clean, hard, tough, rough-surfaced and angular grains of natural sand; manufactured sand prepared from washed stone screenings; stone screenings, slag or gravel; or combinations thereof, after mechanical screening or manufactured by a process approved by the Engineer. The Contractor is prohibited from mixing two or more sources of fine aggregate on the ground for the purpose of feeding into an HMA plant.

- a. All fine aggregate shall meet the listed criteria shown in items #1 thru #7 of Table M.04.01-1. Table M.04.01-1 indicates the quality tests and criteria required for all fine aggregate sources. Individually approved sources of supply shall not be mixed or stored in the same stockpile. The fine aggregates must be free from injurious amounts of clay, loam, and other deleterious materials.

For Superpave mixtures, in addition to the above requirements, the fine aggregate angularity shall be determined by testing the materials passing the #8 sieve in accordance with AASHTO T 304, Method A. Qualification shall be based on the criteria listed in Tables M.04.02-2 thru M.04.02-4. The fine aggregate shall also be tested for clay content as a percentage contained in materials finer than the #8 sieve in accordance with AASHTO T 176.

Table M.04.01-1: Fine Aggregate Criteria by Pit/Quarry Source

Item	Title	AASHTO Protocol	Criteria
1	Grading	T 27 and T 11	100% Passing the 3/8 inch 95% Passing the #4 minimum
2	Absorption	T 84	3% maximum
3	Plasticity limits	T 90	0 or not detectable
4	L.A. Wear	T 96	50% maximum(fine aggregate particle size # 8 and above)
5	Soundness by Magnesium Sulfate	T 104	20% maximum @ 5 cycles
6	Clay Lumps and Friable Particles	T 112	3% maximum
7	Deleterious Criteria	As determined by the Engineer	<u>Deleterious substances include:</u> Organic or inorganic calcite, hematite, shale, clay or clay lumps, friable materials, coal-lignite, shells, loam, mica, clinkers, or organic matter (wood, etc). -Shall not contain more than 3% by mass of any individual listed constituent and not more than 5% by mass in total of all listed constituents.

If Fine aggregate is tested by the CTDOT twice and does not meet above criteria.			
8	Pit/source Petrographic Analysis	C 295 (ASTM)	<ul style="list-style-type: none"> • Required to be performed by the Contractor at no expense to the Department. • Report assignable cause(s), corrective action taken to mitigate source and written request for resample. • If fine aggregate fails upon retest, Contractor may be permitted to request trial use on roadway for evaluation using the subject fine aggregate in HMA, to be monitored for no more than 48 months. • Evaluation location(s); mix size & level; terms and costs related to this application; determination of performance, and approval will be established at the sole discretion of the Engineer.

- b. Basis of Approval: A Quality Control Plan for Fine Aggregate (QCPFA) provided by the Contractor shall be submitted for review and approval for each new source documenting how conformance to Items 1 through 7 as shown in Table M.04.01-1 is monitored. The QCPFA must be resubmitted any time the process, location or manner of how the fine aggregate (FA) is manufactured changes, or as requested by the Engineer. The QCPFA must include the locations and manufacturing processing methods. The QCPFA for any source may be suspended by the Engineer due to the production of inconsistent mixtures.

The Contractor shall submit all test results to the Engineer for review. The Contractor shall also include a washed sieve analysis in accordance with AASHTO T 27/T 11. Any fine aggregate component or final combined product shall have 100% passing the 3/8 inch sieve and a minimum of 95% passing the # 4. The G_{sa}, G_{sb}, and P_{wa} shall be determined in accordance with AASHTO T 84.

The Contractor will be notified by the Engineer if any qualified source of supply fails any portion of Table M.04.01-1. One retest will be allowed for the Contractor to make corrections and/or changes to the process. If, upon retest, the material fails again, the use of the material will not be permitted without additional testing.

The Contractor may solicit additional testing by a third party acceptable to the Engineer to perform a Petrographic analysis (ASTM C 295), at its expense. The Contractor shall submit the results of the analysis with recommended changes to the manufacturing process to the Engineer. The Contractor shall submit fine aggregate samples for testing by the Engineer after the recommended changes have been made.

Upon review of the Petrographic analysis report and identified items that were corrected, the source may be re-sampled and tested by the Engineer.

- c. The Contractor may request that the use of such material not meeting the requirements be considered on select project(s) for certain applications. HMA pavement incorporating such material will be monitored and evaluated for a period not to exceed 48 months, at the direction of the Department and at the expense of the Contractor. Terms of any evaluation and suitable application will be predetermined by the Engineer.

If the Engineer determines, upon evaluation, that the fine aggregate performance is adequate and not harmful to the pavement's serviceability, the Department may approve the material for use in HMA mixtures in similar applications.

3. Mineral Filler:

- a. Requirements: Mineral filler shall consist of finely divided mineral matter such as rock dust, including limestone dust, slag dust, hydrated lime, hydraulic cement, or other accepted mineral matter. At the time of use it shall be freely flowing and devoid of agglomerations. Mineral Filler shall be introduced and controlled at all times during production in a manner acceptable to the Engineer.
- b. Basis of Approval: The request for approval of the source of supply shall include the location, manufacturing process, handling and storage methods for the material. Mineral filler shall conform to the requirements of AASHTO M-17

4. Liquid Bituminous Materials:

- a. Performance grade (PG) binder Requirements:
 - i. Binders shall contain uniformly mixed and blended liquid bituminous materials that are free of contaminants such as fuel oils and other solvents. Such binders shall be properly heated and stored to prevent damage or separation. A PG binder shall be classified by the supplier as a "Neat" binder for each lot and be so labeled on each bill of lading. Neat PG binders shall be asphalts free from modification with: fillers, extenders, reinforcing agents, adhesion promoters, thermoplastic polymers, acid modification and other additives, and shall indicate such information on each bill of lading and certified test report.
 - ii. The blending at mixing plants of PG binder from different suppliers is strictly prohibited. Contractors who blend PG binders will be classified as a supplier and will be required to certify the binder in accordance with AASHTO R-26(M). The asphalt binder shall be Performance Grade 64-22 Neat asphalt. The binder shall meet the requirements of AASHTO M-320(M) and AASHTO R-29(M). The Contractor shall submit a Certified Test Report and bill of lading representing each delivery in

accordance with AASHTO R-26(M). The Certified Test Report must also indicate the binder specific gravity at 77°F; rotational viscosity at 275°F and 329°F and the mixing and compaction viscosity-temperature chart for each shipment.

- iii. The Contractor shall submit the name(s) of personnel responsible for receipt, inspection, and record keeping of PG binder materials. Contractor plant personnel shall document specific storage tank(s) where binder will be transferred and stored until used, and provide binder samples to the Engineer upon request. The person(s) shall assure that each shipment (tanker truck) is accompanied by a statement certifying that the transport vehicle was inspected before loading and was found acceptable for the material shipped and that the binder will be free of contamination from any residual material, along with two (2) copies of the bill of lading.
 - iv. Basis of Approval: The request for approval of the source of supply shall list the location where the material will be manufactured, and the handling and storage methods, along with necessary certification in accordance with AASHTO R-26(M). Only suppliers/refineries that have an approved “Quality Control Plan for Performance Graded Binders” formatted in accordance with AASHTO R-26(M) will be allowed to supply PG binders to Department projects.
- b. Cut-backs (medium cure type)
- i. Requirements: The liquid petroleum materials shall be produced by fluxing an asphalt base with appropriate petroleum distillates to produce the grade specified.
 - ii. Basis of Approval: The request for approval of the source of supply shall be submitted at least seven days prior to its use listing the location where the materials will be produced, and manufacturing, processing, handling and storage methods. The Contractor shall submit a Certified Test Report in accordance with Section 1.06 and a Material Safety Data Sheet (MSDS) for the grade to be used on the Project. The liquid asphalt shall be MC-250 conforming to AASHTO M-82.
- c. Emulsions
- i. Requirements: The emulsified asphalt shall be homogeneous and not be used if exposed to freezing temperatures.
 - ii. Basis of Approval: The request for approval of the source of supply must include the location where the materials will be produced, and manufacturing, processing, handling and storage methods.
 1. Emulsified asphalts shall conform to the requirements of AASHTO M-140. Materials used for tack coat shall not be diluted and meet grade RS-1. When ambient temperatures are 80°F and rising, grade SS-1 or SS-1h may be substituted if accepted by the Engineer. Each shipment shall be accompanied with a Certified Test Report listing Saybolt viscosity, residue by evaporation, penetration of residue, and weight per gallon.

2. Cationic emulsified asphalt shall conform to the requirements of AASHTO M-208(M). Materials used for tack coat shall not be diluted and meet grade CRS-1. The settlement and demulsibility test will not be performed unless deemed necessary by the Engineer. When ambient temperatures are 80°F and rising, grade CSS-1 or CSS-1h may be substituted if accepted by the Engineer. Each shipment shall be accompanied with a Certified Test Report listing Saybolt viscosity, residue by evaporation, penetration of residue, and weight per gallon.

5. Reclaimed Asphalt Pavement (RAP):

- a. Requirements: RAP shall consist of asphalt pavement constructed with asphalt and aggregate reclaimed by cold milling or other removal techniques approved by the Engineer. For bituminous mixtures containing RAP, the Contractor shall submit a JMF in accordance with Article M.04.02 to the Engineer for review.
- b. Basis of Approval: The RAP material will be accepted on the basis of one of the following criteria:
 - i. When the source of all RAP material is from pavements previously constructed on Department projects, the Contractor shall provide a materials certificate listing the detailed locations and lengths of those pavements and that the RAP is only from those locations listed.
 - ii. When the RAP material source or quality is not known, the Contractor shall test the material and provide the following information along with a request for approval to the Engineer at least 30 calendar days prior to the start of the paving operation. The request shall include a material certificate stating that the RAP consists of aggregates that meet the specification requirements of subarticles M.04.01-1 through 3 and that the binder in the RAP is substantially free of solvents, tars and other contaminants. The Contractor is prohibited from using unapproved material on Department projects and shall take necessary action to prevent contamination of approved RAP stockpiles. Stockpiles of unapproved material shall remain separate from all other RAP materials at all times. The request for approval shall include the following:
 1. A 50-pound sample of the RAP to be incorporated into the recycled mixture.
 2. A 25-pound sample of the extracted aggregate from the RAP.
 3. After recovery of binder from the RAP by AASHTO T 170(M), the viscosity test results shall be reported when tested at 140°F by AASHTO T 202 or T 316.
 4. A statement that RAP material has been crushed to 100% passing the ½ inch sieve and remains free from contaminants such as joint compound, wood, plastic, and metals.

6. Crushed Recycled Container Glass (CRCG):

- a. Requirements: The Contractor may propose to use clean and environmentally-acceptable CRCG in an amount not greater than 5% by weight of total aggregate.

- b. Basis of Approval: The Contractor shall submit to the Engineer a request to use CRCG. The request shall state that the CRCG contains no more than 1% by weight of contaminants such as paper, plastic and metal and conform to the following gradation:

CRCG Grading Requirements	
<u>Sieve Size</u>	<u>Percent Passing</u>
3/8-inch	100
No. 4	35-100
No. 200	0.0-10.0

7. Joint Seal Material:

Requirements: Joint seal material shall be a hot-poured rubber compound intended for use in sealing joints and cracks in Asphalt Concrete Pavements. Joint seal material must meet the requirements of AASHTO M-324 – Type 2.

8. Plant production requirements

a. Storage Silos:

- i. The Contractor may use silos for short-term storage of Superpave mixtures with prior notification and approval of the Engineer. A silo must have heated cones and an unheated silo cylinder if it does not contain a separate internal heating system. Prior approval must be obtained for storage times greater than those indicated. When multiple silos are filled, the Contractor shall discharge one silo at a time. Simultaneous discharge of multiple silos is not permitted.

<u>Type of silo cylinder</u>	<u>Maximum storage time for all classes (hr)</u>
Open Surge	4
Unheated – Non-insulated	8
Unheated – Insulated	18
Heated – No inert gas	To be determined by the Engineer

- ii. For all classes of mixture sampled from hauling vehicles at the plant after storage in silos (virgin or mixture containing RAP) except 5, 5A, and 5B, the binder properties of the recovered asphalt shall meet the PG binder grade specified when recovered by AASHTO T 170(M) and tested in accordance with AASHTO R-29 and M-320(M).
- iii. If mixture coming out of a silo continuously does not meet the requirements of M.04.03, or the binder does not meet the PG requirements, the Engineer shall deem that silo unacceptable for use.

- b. Aggregates: The Contractor shall ensure that aggregate stockpiles are managed to provide uniform gradation and particle shape, prevent segregation and cross contamination in a manner acceptable to the Engineer. For drum plants only, the Contractor shall determine the percent moisture content a minimum of twice daily, prior to production and half way through production. The Contractor shall perform cold feed gradation analysis (AASHTO T 27(M) & T 11) for each component aggregate to ensure values remain

within the tolerances stated in Table M.04.02 when compared to the latest JMF for that class.

- c. Mixture: The dry and wet mix times shall be sufficient to provide proper coating (minimum 95% as determined by AASHTO T 195(M)) of all particles with bitumen and produce a uniform mixture. The Contractor shall make necessary adjustments to ensure bituminous concrete mixtures are free from moisture throughout. The Contractor shall make necessary adjustments to ensure all types of bituminous concrete mixtures contain no more than 0.5% moisture throughout when tested in accordance with AASHTO T 329.
- d. RAP: The Contractor shall indicate the percent of RAP, the moisture content (as a minimum, determined twice daily – prior to production and halfway through production), and the net dry weight of RAP added to the mixture on each truck ticket. For each day of production, the production shall conform to the job mix formula and RAP percentage and no change shall be made without the prior approval of the Engineer.
- e. Documentation system: The mixing plant documentation system shall include equipment for accurately proportioning the components of the mixture by weight and in the proper order, controlling the cycle sequence and timing the mixing operations. Recording equipment shall monitor the batching sequence of each component of the mixture and produce a printed record of these operations on each truck ticket, as specified herein. Tolerance controls shall be automatically or manually adjustable to provide proportions within these tolerances for any batch size. The automatic proportioning system shall be capable of consistently delivering mixtures within these limits for the full range of batch sizes.

An asterisk (*) shall be automatically printed next to any individual batch weight(s) exceeding these tolerances. The entire batching and mixing interlock cut-off circuits shall interrupt and stop the automatic batching operations when an error exceeding the acceptable tolerance occurs in proportioning.

Each Aggregate Component:	±1.0 % total target batch weight
Mineral Filler	±0.5 % of the total batch
Bituminous Material	±0.1 % of the total batch
Zero Return (Aggregate)	±0.5 % of the total batch
Zero Return (Bituminous Material)	±0.1 % of the total batch

There must be provisions so that scales are not manually adjusted during the printing process. In addition, the system shall be interlocked to allow printing only when the scale has come to a complete rest. A unique printed character (m) shall automatically be printed on the truck and batch plant printout when the automatic batching sequence is interrupted or switched to auto-manual or full manual during proportioning. For each day's production, each project shall be provided a clear, legible copy of these recordings on each truck ticket.

f. Field Laboratory:

The Contractor shall furnish the Engineer an acceptable field laboratory, to test bituminous mixtures during production and the Engineer shall have priority to use it for testing. The HMA plant production field laboratory shall have a minimum of 300 square feet, have a potable water source and drainage in accordance with the CT Department of Public Health Drinking Water Division, be equipped with all necessary testing equipment as well as with a PC, printer, and telephone with a dedicated hard-wired phone line. In addition, the PC shall have a high speed internet connection with a minimum upstream of 384 Kbps and a functioning web browser with unrestricted access to <https://ctmail.ct.gov>. This equipment shall be maintained in clean and good working order at all times and be made available for use by the Engineer.

The laboratory shall be equipped with a suitable heating system capable of maintaining a minimum temperature of 65°F. It shall be clean and free of all materials and equipment not associated with the laboratory. Windows shall be installed to provide sufficient light and ventilation. During summer months, the laboratory temperature shall not exceed ambient temperature. Light fixtures and outlets shall be installed at convenient locations, and a telephone shall be within audible range of the testing area. The laboratory shall be equipped with an adequate workbench that has a suitable length, width, and sampling tables, and be approved by the Engineer.

The field laboratory testing apparatus, supplies, and safety equipment shall be capable of performing all tests in their entirety that are referenced in AASHTO R 35(M), *Standard Practice for Superpave Volumetric Design for Hot-Mix Asphalt (HMA)* and AASHTO M 323, *Standard Specification for Superpave Volumetric Mix Design*. In addition, the quantity of all equipment and supplies necessary to perform the tests must be sufficient to initiate and complete the number of tests identified in Table M.04.03-2 for the quantity of mixture produced at the plant on a daily basis. The Contractor shall ensure that the Laboratory is adequately supplied at all times during the course of the project with all necessary testing materials and equipment.

g. Mixing Plant and Machinery:

The mixing plant used in the preparation of the bituminous concrete shall comply with AASHTO M-156(M)/ASTM D 995 for a Batch Plant or a Drum Dryer Mixer Plant, and be approved by the Engineer.

M.04.02—Mix design and Job Mix Formula (JMF)

1. Marshall Method - Class 1, 2, 3, 4, 5, 5A, 5B and 12:

- a. Requirements: When specified, the Marshall method shall be employed to develop a bituminous concrete mix design that includes a JMF consisting of target values for gradation and bitumen content for each class of bituminous concrete designated for the project in accordance with the latest Asphalt Institute's MS-2 manual. Each class of bituminous concrete must meet the requirements as shown in Table M.04.02-1.

- b. Basis of Approval: The Contractor shall submit to the Engineer a request for approval of the JMF annually in accordance with one of the methods described herein. Prior to the start of any paving operations, the JMF and production percentage of bitumen must be accepted by the Engineer, and the Contractor must demonstrate the ability to meet the accepted JMF and production percentage of bitumen for each class of mixture. Additionally, the fraction of material retained between any two consecutive sieves shall not be less than 4%.

The Engineer will test each class of mixture for compliance with the submitted JMF and Table M.04.02-1. The maximum theoretical density (Gmm) will be determined by AASHTO T 209(M). If the mixture does not meet the requirements, the JMF shall be adjusted within the ranges shown in Table M.04.02-1 until an acceptable mixture is produced. All equipment, tests and computations shall conform to the Marshall method in accordance with AASHTO T 245(M).

An accepted JMF from the previous operating season may be acceptable to the Engineer provided that there are no changes in the sources of supply for the coarse aggregate, fine aggregate, recycled material (if applicable) and the plant operation had been consistently producing acceptable mixture.

The Contractor shall not change sources of supply after a JMF has been accepted. Before a new source of supply for materials is used, a new JMF shall be submitted to the Engineer for approval.

- c. Marshall mixture (virgin): For bituminous concrete mixtures that contain no recycled material, the limits prescribed in Table M.04.02-1 govern. The Contractor shall submit to the Engineer for approval, a JMF with the individual fractions of the aggregate expressed as percentages of the total weight of the mix and the source(s) of all materials. The JMF shall indicate two bitumen contents; the JMF target percentage and a production percentage (actual amount added to mix) of bitumen for each mix class by total weight. For surface course Class 1, a 0.45 power gradation chart shall also be submitted on which is plotted the percentage passing each sieve. The JMF shall also indicate the target temperature of completed mixture as it is dumped from the mixer and tested in accordance with Article M.04.03.
- d. Marshall mixtures with RAP: In addition to subarticles M.04.02 – 1a through c, RAP in bituminous concrete shall comply with requirements stated in Article M.04.01, and as stated herein. Upon approval of the Engineer, a maximum of 15% RAP may be used with no binder grade modification. RAP material shall not be used with any other recycling option.
- The Contractor may increase the RAP percentage in 5% increments up to a maximum of 30% provided a new JMF is accepted by the Engineer. The following information shall be included in the JMF submittal:
- Gradation and asphalt content of the RAP.
 - Percentage of RAP to be used.
 - Virgin aggregate source(s).

- Total binder content based on total mixture weight.
 - Production pull percentage of added virgin binder based on total mixture weight.
 - Gradation of combined bituminous concrete mixture (including RAP).
 - Grade of virgin added, if greater than 15% of total mix weight.
- e. Marshall mixture with CRCG: In addition to subarticle M.04.02 – 1a through c, for bituminous concrete that contains CRCG, the Contractor shall submit a materials certificate to the Engineer stating that the mixture and its components comply with requirements stated in subarticle M.04.01 - (6). Additionally, 1% hydrated lime, or other accepted non-stripping agent, shall be added to all mixtures containing CRCG. CRCG material shall not be used with any other recycling option.

2. Cold Patch Method - Class 5, 5A, 5B:

- a. Requirements: This mixture must be capable of being stockpiled and workable at all times. A non-stripping agent accepted by the Engineer shall be used in accordance with manufacturer's recommendations. The Contractor shall take necessary steps to ensure that this mixture uses aggregate containing no more than 1% moisture and is not exposed to any rain, snow, or standing water for a period of 6 hours after being mixed. This mixture shall be mixed and stockpiled at the point of production on a paved surface at a height not greater than 4 feet during the first 48 hours prior to its use.
- i. Class 5A mixture shall have 3/8 to 1/2 inch polypropylene fibers that have been approved by the Engineer added at a rate of 6 pounds per ton of mixture.
 - ii. Class 5B mixture shall have 1/4 inch polyester fibers that have been approved by the Engineer added at the rate of 2 1/2 pounds per ton of mixture.
 - iii. Class 5 mixture shall not contain fibers.
- b. Basis of Approval: The aggregates, fibers and binder (MC-250) shall meet the requirements as specified in subarticles M.04.01-1 through 4 and in Table M.04.02-1. The use of recycled material is not permitted with these classes of bituminous concrete. Mixtures not conforming to the binder content as shown in Table M.04.02-1 shall be subject to rejection. There is a two test minimum per day of production. Mixtures not conforming to the gradation as shown in Table M.04.02-1 shall be subject to payment adjustment as specified in Section 4.06.

TABLE M.04.02 – 1 MASTER RANGES FOR MARSHALL BITUMINOUS CONCRETE MIXTURES

Notes: (a) 75 blow (Marshall Criteria). (b) 3-6% when used for a roadway wearing surface. (c) For divided highways with 4 or more lanes, a stability of 1500 lbs is required. (d) Contains an accepted non-stripping compound. (e) To help prevent stripping, the mixed material will be stockpiled on a paved surface and at a height not greater than 4 feet during the first 48 hours. (f) As determined by AASHTO T 245(M). (g) The percent passing the #200 sieve shall not exceed the percentage of bituminous asphalt binder determined by AASHTO T 164(M) or AASHTO T 308(M). (h) Mixture with 5% or more aggregate retained on 3/4" sieve. (i) Mixtures finer than condition (h) above. (j) Class 5 mixture shall contain no fibers. Class 5A mixture shall have 3/8 to 1/2 inch polypropylene fibers that have been previously accepted by the Engineer added at a minimum rate of 6 pounds per ton of mixture. Class 5B mixture shall have 1/4 inch polyester fibers that have been previously accepted by the Engineer added at the minimum rate of 2 1/2 pounds per ton of mixture.

CLASS	1	2	3	4	12	5 (e)(j)	5A (e)(j)	5B (e)(j)	JMF % Tol. (±)
	PG 64-22 5.0 - 6.5	PG 64-22 5.0 - 8.0	PG 64-22 6.5 - 9.0	PG 64-22 4.0 - 6.0	PG 64-22 7.5 - 10.0	MC-250 (d) 6.0 - 7.5	MC-250 (d) 6.0 - 7.5	MC-250 (d) 6.0 - 7.5	
Sieve Size	Percent Passing (%)								
# 200	3.0 - 8.0 (g)	3.0 - 8.0 (g)	3.0 - 8.0 (g)	0.0 - 5.0 (g)	3.0 - 10.0 (g)	0.0 - 2.5	0.0 - 2.5	0.0 - 2.5	2.0
# 50	6 - 26	8 - 26	10 - 30	5 - 18	10 - 40				4
# 30	10 - 32	16 - 36	20 - 40		20 - 60	2 - 15	2 - 15	2 - 15	5
# 8	28 - 50	40 - 64	40 - 70	20 - 40	60 - 95	10 - 45	10 - 45	10 - 45	6
# 4	40 - 65	55 - 80	65 - 87	30 - 55	80 - 95	40 - 100	40 - 100	40 - 100	7
1/4"									
3/8 "	60 - 82	90 - 100	95 - 100	42 - 66	98 - 100	100	100	100	8
1/2 "	70 - 100	100	100		100				8
3/4"	90 - 100			60 - 80					8
1"	100								
2"				100					

Additionally, the fraction of material retained between any two consecutive sieves shall not be less than 4%

Mixture Temperature	
Binder	325° F maximum
Aggregate	280-350° F
Mixtures	265-325° F
	275-325° F
	140-185° F
	100-175° F
	120-175° F
	25° F
Mixture Properties	
VOIDS - %	0 - 4.0
Stability (f) lbs. min.	1000
FLOW (f) in.	.08 - .15
VMA % - min.	15(h) :16 (i)
	0 - 5.0 (a)
	1000
	.08 - .15

3. Superpave Design Method – S0.25, S0.375, S0.5, and S1

- a. Requirements: The Contractor or its representative shall design and submit Superpave mix designs annually for approval. The design laboratory developing the mixes shall be approved by the Engineer. The mix design shall contain the nominal maximum aggregate size and include a JMF consisting of target values for gradation and bitumen content for each HMA mix type designated for the project, as specified in Tables M.04.02-2 thru Table M.04.02-5 and in accordance with the latest requirements of AASHTO M 323(M) and AASHTO R 35(M).

The contractor shall provide a certified test report with supporting documentation from an accredited AASHTO Materials Reference Laboratory (AMRL) with the use of NETTCP Certified Technicians for aggregate consensus properties for each type & level, as specified in Table M.04.02-3. In addition the G_{sa} , G_{sb} , P_{wa} shall also be provided for each component aggregate. New mixes shall be tested in accordance with AASHTO T 283(M) *Standard Method of Test for Resistance of Compacted Hot Mix Asphalt (HMA) to Moisture-Induced Damage*. The AASHTO T 283(M) test results and specimens shall be submitted by the Contractor for review. The tensile strength ratio must be greater than 80 percent, and the specimen shall not show more than minimal evidence of stripping as determined by the Engineer. The mix design shall conform to all criteria applicable to the selected traffic level equivalent single-axle loads (ESAL) as specified in this contract. Each HMA mix type must meet the requirements shown in Tables M.04.02-2 thru Table M.04.02-5.

In addition, minimum binder content values apply to all types of HMA mixtures, as stated in Table M.04.02-5. For mixtures containing RAP, the virgin production and the anticipated proportion of binder contributed by the RAP cannot be less than the total permitted binder content value for that type nor the JMF minimum binder content.

Superpave Mixture (virgin): For HMA mixtures that contain no recycled material, the limits prescribed in Tables M.04.02-2 thru Table M.04.02-5 apply. The Contractor shall submit a JMF, on a form provided by the Engineer, with the individual fractions of the aggregate expressed as percentages of the total weight of the mix and the source(s) of all materials to the Engineer for approval. The JMF shall indicate the corrected target binder content and applicable binder correction factor (ignition oven or extractor) for each mix type by total weight of mix. The mineral filler (dust) shall be defined as that portion of blended mix that passes the #200 sieve by weight when tested in accordance with AASHTO T 30(M). The dust-to-effective asphalt (D/Pbe) ratio shall be between 0.6 and 1.2 by weight. The dry/wet mix times and hot bin proportions (batch plants only) for each type shall be included in the JMF.

The percentage of aggregate passing each sieve shall be plotted on a 0.45 power gradation chart and shall be submitted for all HMA mixtures. This chart shall delineate the percentage of material passing each test sieve size as defined by the JMF. The percentage of aggregate passing each standard sieve shall fall within the specified control

points, but outside the restricted zone limits as shown in Tables M.04.02-2 thru Table M.04.02-5. Mixes with documented performance history which pass through the restricted zone may be permitted for use as long as all other physical and volumetric criteria meets specifications as specified in Tables M.04.02-2 thru Table M.04.02-5 and with prior approval from the Engineer. A change in the JMF requires that a new chart be submitted.

Superpave Mixtures with RAP: In addition to subarticles M.04.02 – 3 a through c, for HMA that contains RAP, the Contractor shall submit a materials certificate to the Engineer stating that the RAP complies with requirements stated in Article M.04.01. Upon approval of the Engineer, the use of RAP will be allowed with the following conditions:

- RAP amounts up to 15% may be used with no binder grade modification.
- RAP amounts up to 20% may be used provided a new JMF is approved by the Engineer. The JMF submittal shall include the grade of virgin binder added and test results that show the combined binder (recovered binder from the RAP and virgin binder at the mix design proportions) meets the requirements of the specified binder grade.

The RAP shall be crushed after milling or other removal method so that 100 % passes the 0.5 inch sieve. Also, under no circumstances shall the top-size aggregate in the RAP exceed the nominal maximum aggregate size allowed by the job mix formula for that mix. The Contractor shall assure that the RAP is free from contaminating substances such as joint seal compound. The aggregate type used, either gravel, trap rock or a blend of the two, shall be maintained and consistent throughout the entire roadway. The final Superpave mixture shall conform to specifications as amended herein. RAP material shall not be used with any other recycling option.

- b. Basis of Approval: On an annual basis the Contractor shall submit to the Engineer a request for approval of the HMA mixture, the mix design, and JMF in accordance with one of the methods described herein. Prior to the start of any paving operations, the JMF must be approved by the Engineer, and the Contractor must demonstrate the ability to meet the accepted JMF and production percentage of bitumen for each type of mixture. HMA mixture supplied to the project without an approved mix design, JMF and approved facility will be rejected. The JMF shall also indicate the target temperature of completed mixture as it is dumped from the mixer and tested in accordance with Article M.04.03. Additionally, the fraction of material retained between any two consecutive sieves shall not be less than 4%.

HMA Plant Trials: Upon submittal and approval of the mix design by the Engineer, the Contractor shall test and evaluate plant-produced mixture (PPT) in accordance with these specifications when required.

The JMF shall be accepted if the HMA Plant mixture and materials meet all criteria as specified in Tables M.04.02-2 thru Table M.04.02-5. If the mixture does not meet the requirements, the contractor shall adjust the JMF within the ranges shown in Tables M.04.02-2 thru Table M.04.02-5 until an acceptable mixture is produced. All equipment, tests, and computations shall conform to the latest AASHTO R-35(M) and AASHTO M-323(M).

Any JMF, once approved, shall only be acceptable for use when it is produced by the designated HMA plant, it utilizes the same component aggregates and binder source, and it continues to meet all criteria as specified herein, and component aggregates are maintained within the tolerances shown in Table M.04.02-2.

The Contractor shall not change any component source of supply including consensus properties after a JMF has been accepted. Before a new source of materials is used, a revised JMF shall be submitted to the Engineer for approval. Any approved JMF applies only to the plant for which it was submitted. Only one mix with one JMF will be approved for production at any one time. Switching between approved JMF mixes with different component percentages or sources of supply is prohibited.

The following information must be included in the mix design submittal:

- a. Gradation, specific gravities and asphalt content of the RAP,
- b. Material Certificate stating that all RAP inventory conforms to all material specifications,
- c. Percentage of RAP to be used.

Superpave mixture with CRCG: In addition to subarticles M.04.02 – 3 a through c, for HMA mixtures that contain CRCG, the Contractor shall submit a materials certificate to the Engineer stating that the CRCG complies with requirements stated in Article M.04.01, as applicable. Additionally, 1% hydrated lime, or other accepted non-stripping agent, shall be added to all mixtures containing CRCG. CRCG material shall not be used with any other recycling option.

- c. Mix Status: Each Plant will have each type of HMA mixture evaluated based on previous years production compliance, for the next construction paving season, as determined by the Engineer. Based on the rating a type receives it will determine whether the mixture can be produced without the prior completion of a PPT. Ratings will be provided to each HMA producer annually at the beginning of the paving season.

- 1) Rating Procedure: Ratings for each type are as follows:

“A” – Approved:

Rating assigned to a mixture type from a producer with a current rating of 70% or better based on specification compliance based on binder content (Pb), air voids (Va), maximum theoretical gravity (G_{mm}), and Voids in Mineral Aggregate (VMA).

“PPT” – Pre-Production Trial:

Rating assigned to a type of mixture when there is no production history from the previous year, has a change in one or more aggregate components from the JMF on record, a change in RAP percentage, or is a new JMF not previously on record.

HMA mixtures rated with a “PPT” cannot be shipped or used on Department projects. A passing “PPT” test shall be performed with NETTCP certified personnel on that type of mixture by the HMA producer and meet all specifications (Table M.04.02-2 thru Table M.04.02-5) before production shipment may be resumed. At no time shall mixture rated “PPT” be shipped to Department projects.

Contractors that have mix types rated a “PPT” may use one of the following methods to change the rating to an “A.”

Option A: Schedule a day when a Department inspector can be at the HMA facility to witness a passing “PPT” test or,

Option B: When the Contractor or their representative performs a “PPT” test without being witnessed by an inspector, the Contractor shall submit the test results and a split sample including 2 gyratory molds, 5,000 grams of boxed HMA for binder and gradation determination, and 5,000 grams of cooled loose HMA for Gmm determination for verification testing and approval. Passing verifications will designate the HMA type to be on an “A” status. Failing verifications will require the contractor to submit additional trials.

Option C: When the Contractor or their representative performs a “PPT” test without being witnessed by a Department inspector, the Engineer may verify the mix in the Contractor’s laboratory. Passing verifications will designate the HMA type to be an “A” status. Failing verifications will require the Contractor to submit additional trials.

When Option (A) is used and the “PPT” test meets all specifications, the “PPT” test is considered a passing test and the rating for that mix is changed to “A”. When the “PPT” test is not witnessed, the “PPT” Option (B) procedure must be followed and the mixtures along with the test results delivered to the Materials Testing Lab. The test results must meet the “B” tolerances established by the Engineer.

“U” – No Acceptable Mix Design on File:

Rating assigned to a type of mixture that does not have a JMF submitted, or the JMF submitted has not been approved, or is incomplete. A mix design or JMF must be submitted annually seven (7) days prior in order to obtain an “A,” or “PPT” status for that mix. A “U” will be used only to designate the mix status until the mix design has been approved, and is accompanied with all supporting data as specified. HMA mixtures rated with a “U” cannot be used on Department projects.

TABLE M.04.02- 2: SUPERPAVE MASTER RANGE FOR MIXTURE DESIGN CRITERIA

Notes: (1) Minimum Pb as specified in Table M.04.02-5. (2) Voids in Mineral Aggregates shall be computed as specified herein. (3) Control point range is also defined as the master range for that mix. (4) Dust is considered to be the percent of materials passing the #200 sieve.

Sieve	S0.25				S0.375				S0.5				S1			
	CONTROL POINTS ⁽³⁾		RESTRICTED ZONE		CONTROL POINTS ⁽³⁾		RESTRICTED ZONE		CONTROL POINTS ⁽³⁾		RESTRICTED ZONE		CONTROL POINTS ⁽³⁾		RESTRICTED ZONE	
inches	Min (%)	Max (%)	Min (%)	Max (%)	Min (%)	Max (%)	Min (%)	Max (%)	Min (%)	Max (%)	Min (%)	Max (%)	Min (%)	Max (%)	Min (%)	Max (%)
2.0	-	-	-	-	-	-	-	-	-	-	-	-	-	-	-	-
1.5	-	-	-	-	-	-	-	-	-	-	-	-	100	-	-	-
1.0	-	-	-	-	-	-	-	-	-	-	-	-	90	100	-	-
3/4	-	-	-	-	-	-	-	-	100	-	-	-	-	90	-	-
1/2	100	-	-	-	100	-	-	-	90	100	-	-	-	-	-	-
3/8	97	100	-	-	90	100	-	-	-	90	-	-	-	-	-	-
#4	-	90	-	-	-	90	-	-	-	-	-	-	-	-	39.5	39.5
#8	32	67	47.2	47.2	32	67	47.2	47.2	28	58	39.1	39.1	19	45	26.8	30.8
#16	-	-	31.6	37.6	-	-	31.6	37.6	-	-	25.6	31.6	-	-	18.1	24.1
#30	-	-	23.5	27.5	-	-	23.5	27.5	-	-	19.1	23.1	-	-	13.6	17.6
#50	-	-	18.7	18.7	-	-	18.7	18.7	-	-	15.5	15.5	-	-	11.4	11.4
#100	-	-	-	-	-	-	-	-	-	-	-	-	-	-	-	-
#200	2.0	10.0	-	-	2.0	10.0	-	-	2.0	10.0	-	-	1.0	7.0	-	-
Pb ⁽¹⁾	-	-	-	-	-	-	-	-	-	-	-	-	-	-	-	-
VMA ⁽²⁾ (%)	16.0 ± 1		16.0 ± 1		16.0 ± 1		16.0 ± 1		15.0 ± 1		15.0 ± 1		13.0 ± 1		13.0 ± 1	
VA (%)	4.0 ± 1		4.0 ± 1		4.0 ± 1		4.0 ± 1		4.0 ± 1		4.0 ± 1		4.0 ± 1		4.0 ± 1	
Gse	JMF value		JMF value		JMF value		JMF value		JMF value		JMF value		JMF value		JMF value	
Gmm	JMF ± 0.030		JMF ± 0.030		JMF ± 0.030		JMF ± 0.030		JMF ± 0.030		JMF ± 0.030		JMF ± 0.030		JMF ± 0.030	
Dust/Pbe ⁽⁴⁾	0.6 - 1.2		0.6 - 1.2		0.6 - 1.2		0.6 - 1.2		0.6 - 1.2		0.6 - 1.2		0.6 - 1.2		0.6 - 1.2	
Agg. Temp	280 - 350F		280 - 350F		280 - 350F		280 - 350F		280 - 350F		280 - 350F		280 - 350F		280 - 350F	
Mix Temp	265 - 325 F		265 - 325 F		265 - 325 F		265 - 325 F		265 - 325 F		265 - 325 F		265 - 325 F		265 - 325 F	

**TABLE M.04.02-3
SUPERPAVE MASTER RANGE FOR CONSENSUS PROPERTIES OF COMBINED AGGREGATE STRUCTURES**

Traffic Level	Design ESALs (80 kN)	Coarse Aggregate Angularity (1) ASTM D 5821	Fine Aggregate Angularity (7) AASHTO T 304	Flat or Elongated Particles ASTM D 4791	Sand Equivalent AASHTO T 176
-----	(million)			> #4	-----
1*	< 0.3	55/- -	40	10	40
2	0.3 to < 3.0	75/- -	40	10	40
3	≥ 3.0	95/90	45	10	45
	Design ESALs are the anticipated project traffic level expected on the design lane, projected over a 20 year period, regardless of the actual expected design life of the roadway.	Criteria presented as minimum values. 95/90 denotes that a minimum of 95% of the coarse aggregate, by mass, shall have one fractured face and that a minimum of 90% shall have two fractured faces.	Criteria presented as minimum percent air voids in loosely compacted fine aggregate passing the #8 sieve.	Criteria presented as maximum Percent by mass of flat or elongated particles of materials retained on the #4 sieve, determined at 3:1 ratio.	Criteria presented as minimum values for fine aggregate passing the #8 sieve.

* NOTE: Level 1 for use by Towns and Municipalities ONLY.

TABLE M.04.02- 4: SUPERPAVE MASTER RANGE FOR TRAFFIC LEVELS AND DESIGN VOLUMETRIC PROPERTIES.

Traffic Level	Design ESALs (million)	Number of Gyration by Superpave Gyrotory Compactor		Percent Density of Gmm from HMA specimen		Voids Filled with Asphalt (VFA) Based on Nominal mix size – inch				
		Nini	Nmax	Nini	Ndes	Nmax	Ndes			
1*	< 0.3	6	75	≤ 91.5	96.0	≤ 98.0	0.25	0.375	0.5	1
2	0.3 to < 3.0	7	115	≤ 90.5	96.0	≤ 98.0	65 - 78	65 - 78	65 - 78	65 - 78
3	≥ 3.0	8	160	≤ 90.0	96.0	≤ 98.0	73 - 76	73 - 76	65 - 75	65 - 75

* NOTE: Level 1 for use by Towns and Municipalities ONLY.

**TABLE M.04.02– 5: SUPERPAVE MINIMUM BINDER CONTENT
BY MIX TYPE & LEVEL.**

Mix Type	Level	Binder Content Minimum ⁽¹⁾
S0.25	1*	5.6
S0.25	2	5.5
S0.25	3	5.4
S0.375	1*	5.6
S0.375	2	5.5
S0.375	3	5.4
S0.5	1*	5.0
S0.5	2	4.9
S0.5	3	4.8
S1	1*	4.6
S1	2	4.5
S1	3	4.4

* NOTE: Level 1 for use by Towns and Municipalities ONLY.

M.04.03—Production Quality Control (QC) Testing, Approval and Control of Mixture:

The Contractor shall submit a Quality Control plan for HMA production specifically for the plant producing the HMA mixture in accordance with subarticle 4.06.03-9 for review and approval of the Engineer. The plan must also include a list of sampling & testing methods and frequencies used during production, and the names of all Quality Control plant personnel and their duties. In addition;

- i. All plant personnel involved with sampling and testing for Quality Control purposes must have a current certification as an NETTCP HMA Plant Technician or Interim HMA Plant Technician and be in good standing. Technicians found by the Engineer to be non-compliant with NETTCP and Department policies may be suspended by the Engineer from participating in the production of mixtures for Department projects until their actions can be reviewed by NETTCP.
- ii. The Contractor shall maintain a list of laboratory equipment used in their quality control processes including but not limited to, balances, scales, manometer/vacuum gauge, thermometers, gyratory compactor, clearly showing calibration and/or inspection dates, in accordance with AASHTO R-18.

In addition, based on the mix design method the following also applies.

1. **Materials Sampling & Testing Methods for Marshall Mixes:** The Contractor shall furnish the Engineer a field laboratory accepted by the Engineer to test bituminous mixtures during production. Material samples will be obtained from the hauling vehicles by the Engineer at the plant during each day's production as indicated in the Department's "Schedule of

Minimum Requirements for Sampling Materials for Test.” The following test procedures will be used:

AASHTO T 30(M)	Mechanical Analysis of Extracted Aggregate
AASHTO T 40(M)	Sampling Bituminous Materials
AASHTO T 164(M)/ AASHTO T 308(M)	Quantitative Extraction/Ignition Oven of Bitumen from Bituminous Paving Mixtures
AASHTO T 245(M)	Resistance to Plastic Flow of Bituminous Mixtures Using Marshall Apparatus
AASHTO T 209(M)	Theoretical Maximum Specific Gravity and Density of Bituminous Paving Mixtures
AASHTO T 269(M)	Percent Air Voids in Compacted Dense and Open Bituminous Paving Mixtures
AASHTO T 329	Moisture Content of Hot-Mix Asphalt (HMA) by Oven Method

- a. Cessation of Supply: Marshall Mix Production shall cease for the Project from any plant that consistently fails to produce mixture that meets the JMF and volumetric properties. The criteria for ceasing the supply of a class of mixture from any plant are as follows:
 - i. Off-Test Status: The results of AASHTO T 164(M) and T 30(M) will be used to determine if the mixture is within the tolerances shown in Table M.04.02-1. The Contractor will be notified that a plant is "off test" for a class of mixture when the test results indicate that any single value for bitumen content or gradation are not within the tolerances shown in Table M.04.02-1 for that class of mixture.
 - ii. When multiple plants and silos are located at one site, mixture supplied to one project is considered as coming from one source for the purpose of applying the “off test” adjusted payment.
 - iii. If a test indicates that the bitumen content or gradation are outside the tolerances, the Contractor may make a single JMF change on classes 1, 2, 3, 4 and 12 as allowed by the Engineer prior to any additional testing. A JMF change shall include the date and name of the Engineer that allowed it. Consecutive test results outside the requirements of Table M.04.02-1 JMF tolerances may result in rejection of the mixture.
 - iv. The Engineer may cease supply of mixture from the plant when the test results from three non-consecutive samples of a class of mixture are not within the JMF tolerances or the test results from two non-consecutive samples not within the master range indicated in Table M.04.02-1 during any one production period, due to inconsistent production.
 - v. Any modification to the JMF shall not exceed 50% of the JMF tolerances indicated in Table M.04.02-1 for any given component of the mixture without approval of the Engineer. When such an adjustment is made to the bitumen, the corresponding production percentage of bitumen shall be revised accordingly.

- b. Adjustments for Off test Mixture under Cessation of Supply: The HMA plant shall cease supplying to the project:
 - i. When the test results from three consecutive samples are “off test” and not within the JMF tolerances or,
 - ii. The test results from two consecutive samples are “off test” and not within the ranges indicated in Table M.04.02 – 1 or,
 - iii. When the percent of material passing the minus #200 sieve material exceeds the percent of extracted bitumen content for three consecutive samples during any production period of the values stated in Table M.04.02-1:
 - a. The quantity of mixtures shipped to the project determined to be “off test” and outside the tolerances will be tabulated by the Engineer and will be adjusted in accordance with Section 4.06.
 - b. Following cessation, a trial production period will be required at the plant for that class of mixture. Use of that class of mixture from that plant will be prohibited on the Project until the plant has demonstrated the ability to consistently produce acceptable mixture.
 - c. When the Engineer has accepted the mixtures from the trial production period, the use of that mixture on the Project may resume.

2. Material Sampling & Testing Methods for Superpave Mixes:

- a. Samples of mixtures will be obtained from the hauling vehicles at the plant during each day's production, as indicated in Table M.04.03– 1. The Contractor shall perform necessary moisture susceptibility testing annually or when material component sources change, and for all levels of HMA S0.5 plant produced mixtures, as specified in the latest version of AASHTO T 283(M). The AASHTO T 283(M) test results and specimens shall be submitted by the Contractor for approval. The tensile strength ratio must be greater than 80 percent, and the specimen shall not show more than minimal evidence of stripping as determined by the Engineer. This shall be completed within 30 days of beginning of production. Superpave mixtures that require anti-strip additives (either liquid or mineral) shall continue to meet all requirements specified herein for binder and HMA. The Contractor shall submit the name, manufacturer, percent used, and MSDS sheet for the anti-strip additive (if applicable) to the Engineer. In addition;
 - i. The Contractor shall maintain all testing equipment within a field laboratory in good working order.
 - ii. The Contractor shall not modify or use the equipment within the field laboratory without the consent of the Engineer. Any such action by the Contractor may be cause for the Engineer to re-inspect equipment, check calibrations, which could delay production at that facility until such checks are completed.
 - iii. The Contractor shall take immediate action to replace, repair, and/or recalibrate any piece of equipment that is deemed by the Engineer to be out of calibration, malfunctioning, or not in operation. If an acceptance test was performed using such

- equipment, split test samples may be retrieved for verification at the discretion of the Engineer.
- iv. Production without the use of required testing equipment will be permitted for only 1 hour. Additional production beyond the first hour may be considered by the Engineer. If permitted to continue production, box samples will be taken, tested, and incorporated as stated in Article M.04.03 and subarticle 4.06.04-1b. No production shall be permitted beyond that day until the subject equipment is repaired or replaced to the satisfaction of the Engineer.
 - v. Compaction of samples shall be accomplished utilizing an accepted Superpave Gyratory Compactor (SGC), supplied by the Contractor. The SGC shall be located at the HMA plant supplying mixture to the project.
 - vi. The Engineer is responsible for determining the acceptance of HMA and will perform verification testing on QC production samples in accordance with the Department's QA Program for Materials..
- b. Additional QC plan Requirements for Plants producing Superpave Mix Design mixture:
- i. The Contractor shall perform all listed component aggregates and Superpave mixture Quality Control testing in accordance with the test procedures and schedule listed in Table M.04.03-1, as a minimum, any day that Superpave mixtures are produced.
 - ii. The Contractor shall propose a QC test frequency for AASHTO T 27(M) on the cold feed material and AASHTO T 308 for RAP binder content.
 - iii. All process control (PC) test data shall be kept on file for the duration of the project for review by the Engineer.
- c. Determination of Off-Test status:
- i. Off Test Status: Superpave mixes shall be considered "*off test*" when any Control Point Sieve, VA, VMA, and Gmm values are outside of the limits specified in Table M.04.03-3 and the computed binder content (Pb) established by AASHTO T308(M) or as documented on the vehicle delivery ticket is below the minimum binder content stated in subarticle M.04.03-5. Note that further testing of samples or portions of samples not initially tested for this purpose cannot be used to change the status.
 - ii. Any time the HMA mixture is considered Off-test:
 1. The Contractor shall notify the Engineer (and project staff) when the plant is "*off test*" for a type of mixture. When multiple plants and silos are located at one site, mixture supplied to one project is considered as coming from one source for the purpose of applying the "*off test*" determination.
 2. The Contractor must take immediate actions to correct the deficiency, minimize "*off test*" production to the project, and obtain an additional Process Control (PC) test after any corrective action to verify production is in conformance to the

specifications. A PC test will not be used for acceptance and is solely for the use of the Contractor in its quality control process.

d. Test Section:

The test section, as specified in Section 4.06, shall be considered acceptable if payment for HMA mixture tested at the plant is no less than 100% and the field density meets the specified requirements.

**Table M.04.03– 1: Contractor Quality Control Testing Procedures
& Minimum Frequency of Test**

Protocol	Reference	Description	Frequency (min)
1	AASHTO T 27	Sieve Analysis of Fine and Coarse Aggregate	Determined by Contractor
2	AASHTO T 329	Moisture content of RAP (before start and halfway thru production - when used)	2/day
3	AASHTO T 255(M)	Moisture content of each cold feed aggregate (before start and halfway thru production - drum plants only)	2/day
4	AASHTO T 308(M)	Binder content of RAP by Ignition Oven method (before start of production when used)	Determined by Contractor
5	AASHTO T 168(M)	Sampling of HMA	See Note (3)
6	AASHTO T 308(M)	Binder content by Ignition Oven method (adjusted for aggregate correction factor)	See Note (3) & Note (4)
7	AASHTO T 30(M)	Gradation of extracted aggregate for HMA mixture	See Note (3)
8	AASHTO T 312(M)	⁽¹⁾ Superpave Gyrotory molds compacted to N_{des}	See Note (3)
9	AASHTO T 166(M)	⁽²⁾ Bulk specific gravity of HMA	See Note (3)
10	AASHTO R 35(M)	⁽²⁾ Air voids, VMA	See Note (3)
11	AASHTO T 209(M)	Maximum specific gravity of HMA (average of two tests)	See Note (3)
12	AASHTO T 329	Moisture content of Production HMA	See Note (3)
<p>Notes: (1) One set equals two six-inch molds. Molds to be compacted to N_{max} for PPTs and N_{des} for production testing (2) Average value of one set of six-inch molds. (3) Test frequency shall be based on HMA quantity produced per day. Table M.04.03-2 denotes the number of tests required for daily QC by the Contractor. (4) The aggregate correction factor will be determined by the Engineer.</p>			

**Table M.04.03 – 2: Contractor Acceptance Testing Required
Based on Daily Production per Type/Level/Plant⁽¹⁾**

Daily quantity produced in tons	Minimum number of tests required ⁽²⁾
0 to 150	No testing required (if mix already accepted) ⁽³⁾
151 to 600	1 test
601 to 1,200	2 tests
1,201 to 1,800	3 tests
1,801 and greater ⁽⁴⁾	4 tests

Notes:

(1) For the purpose of the Contractor complying with the number of tests stated in Table M.04.03-2, tons of the same type/level per plant shall be combined from multiple state projects. A minimum of one (1) acceptance test shall be performed for every four days of production for every same type/level mix (days of production may or may not be consecutive days). An acceptance test shall not be performed within 150 tons of production from a previous acceptance test unless approved by the Engineer.

(2) All testing shall be selected using stratified – random sampling of total estimated daily tons in accordance with ASTM D 3665, except that the first test shall be randomly taken from the first round of trucks, the first 151 tons subplot, or as otherwise ordered by the Engineer. QC samples shall be saved and stored at the HMA facility for 7 days for Engineer retrieval, after which they may be disposed of.

(3) When directed by the Engineer, a minimum of 1 test is required for bridge and critical areas.

(4) An additional random test shall be taken by the Contractor for each additional 600 tons.

- e. Cessation of Supply for Superpave mixtures with no payment adjustment: Production of HMA shall cease for the Project from any plant that consistently fails to produce mixture that meets the JMF and volumetric properties. The quantity of Superpave mixtures shipped to the project that is “off-test” will not be adjusted for deficient mixtures.

An HMA production plant will be required to cease supplying mixtures to the project when:

1. HMA mixture is “off test” on three (3) consecutive tests for VMA or Gmm, regardless of date of production due to inconsistency (i.e., small production requires 1 test per day for multiple days).
2. HMA mixture is “off test” on two (2) consecutive tests for the Control Point sieves in one day’s production.
3. Following cessation, the Contractor shall immediately make necessary material or HMA plant corrections and run a Pre-Production Trial (PPT) for that type of mixture. Use of that type of mixture from that plant will be prohibited to the Project until the plant has demonstrated the ability to consistently produce acceptable mixture. When the Contractor has a passing test and has received approval from the Engineer, the use of that mixture to the Project shall resume.

f. Cessation of Supply for Superpave mixtures with payment adjustment:

Production of HMA shall cease for the Project from any plant that consistently fails to produce mixture that meets the Superpave minimum binder content by mix type and level listed in Table M.04.02-5. The quantity of Superpave mixtures shipped to the project that is “off-test” will be adjusted for deficient mixtures in accordance with Section 4.06.

An HMA production plant will be required to cease supplying mixtures to the project when:

1. The binder content (Pb) is below the requirements of Table M.04.03-5 on the ignition oven test result after two (2) consecutive tests, regardless of date of production.
2. Following cessation, the Contractor shall immediately make necessary material or HMA plant corrections and run a Pre-Production Trial (PPT) for that type of mixture. Use of that type of mixture from that plant will be prohibited to the Project until the plant has demonstrated the ability to consistently produce acceptable mixture. When the Contractor has a passing test and has received approval from the Engineer, the use of that mixture to the Project shall resume.

3. **JMF Changes for Superpave mixtures production:** It is understood that a JMF change is effective from the time it was submitted forward and is not retroactive to the previous test or tests. JMF changes are permitted to allow for trends in aggregate and mix properties but every effort shall be employed by the Contractor to minimize this to ensure a uniform and dense pavement.

- a. JMF changes to the G_{mm} or mix Absorption Correction Factor (A_{cf}) are only permitted prior to or after a production shift for all HMA types of mixtures and only when they:
 - i. Are requested in writing and pre-approved by the Engineer;
 - ii. Are based on a minimum of a two test trend;
 - iii. Are documented with a promptly submitted revised JMF on form provided by the Engineer.
 - iv. A revised JMF submittal shall include the date and name of the Engineer that allowed it.

TABLE M.04.03- 3: SUPERPAVE MASTER RANGE FOR HMA MIXTURE PRODUCTION

Sieve	S0.25		S0.375		S0.5		S1		Tolerances JMF Limits (4)
	Min (%)	Max (%)	Min (%)	Max (%)	Min (%)	Max (%)	Min (%)	Max (%)	
inches									± Tol
2.0	-	-	-	-	-	-	-	-	
1.5	-	-	-	-	-	-	100	-	
1.0	-	-	-	-	-	-	90	100	
3/4	-	-	-	-	100	-	-	90	
1/2	100	-	100	-	90	100	-	-	
3/8	97	100	90	100	-	90	-	-	
#4	-	90	-	90	-	-	-	-	
#8	32	67	32	67	28	58	19	45	
#16	-	-	-	-	-	-	-	-	
#200	2.0	10.0	2.0	10.0	2.0	10.0	1.0	7.0	
Pb(2)	-	-	-	-	-	-	-	-	note (2)
VMA (%)	16.0		16.0		15.0		13.0		1.0
VA (%)	4.0		4.0		4.0		4.0		1.0
Gmm	JMF value		JMF value		JMF value		JMF value		0.030
Agg. Temp	280 – 350F		280 – 350F		280 – 350F		280 – 350F		
Mix Temp	265 – 325 F (1)		265 – 325 F (1)		265 – 325 F (1)		265 – 325 F (1)		

Notes: (1) 300°F minimum after October 15. (2) Minimum Pb as specified in Table M.04.03-5 (3) Control point range is also defined as the master range for that mix. (4) JMF tolerances shall be defined as the limits for production compliance. VA & Pb payment is subject to adjustments, as defined in sub-article 4.06.04 - 2.

TABLE M.04.03– 4: SUPERPAVE MASTER RANGE FOR TRAFFIC LEVELS AND DESIGN VOLUMETRIC PROPERTIES.

Traffic Level	Design ESALs	Number of Gyration by Superpave Gyrotory Compactor	
	(million)	Nini	Ndes
1*	< 0.3	6	50
2	0.3 to < 3.0	7	75
3	≥3.0	8	100

* NOTE: Level 1 for use by Towns and Municipalities ONLY.

TABLE M.04.03– 5: SUPERPAVE MINIMUM BINDER CONTENT BY MIX TYPE & LEVEL.

Mix Type	Level	Binder Content Minimum ⁽¹⁾
S0.25	1*	5.6
S0.25	2	5.5
S0.25	3	5.4
S0.375	1*	5.6
S0.375	2	5.5
S0.375	3	5.4
S0.5	1*	5.0
S0.5	2	4.9
S0.5	3	4.8
S1	1*	4.6
S1	2	4.5
S1	3	4.4

* NOTE: Level 1 for use by Towns and Municipalities ONLY.

**Table M.04.03-6:
Modifications to Standard AASHTO and ASTM Test Specifications and Procedures.**

AASHTO Standard Specification							
Reference	Modification						
AASHTO M 320	<p>1. Mass change for PG 64-22 shall be a maximum loss of 0.5% when tested in accordance with AASHTO T 240.</p> <p>2. The two bottles used for the mass change determination may be re-heated and used for further testing.</p>						
AASHTO Standard Methods of Test							
Reference	Modification						
AASHTO T 27	Section 7.7 Samples are not washed						
AASHTO T 30	Section 6.2 thru 6.5 Samples are not routinely washed						
AASHTO M-156 /ASTM D 995	<p>Section 8.7.3 <i>Accuracy: Batch Plants</i> The automation proportioning system shall be capable of consistently delivering mixtures within the full range of batch sizes within the following tolerances:</p> <table border="0" style="margin-left: auto; margin-right: auto;"> <tr> <td style="text-align: center;"><i>Total Batch Weight Of</i></td> <td></td> </tr> <tr> <td style="text-align: center;"><i>Paving Mix. %</i></td> <td></td> </tr> <tr> <td style="text-align: center;"><i>Batch aggregate component</i></td> <td style="text-align: center;">$\pm 1.0\%$</td> </tr> </table> <p>Note: AASHTO T 40 is modified as follows: Section 9.1.1 Sampling valve is located on bottom third of storage tank.</p>	<i>Total Batch Weight Of</i>		<i>Paving Mix. %</i>		<i>Batch aggregate component</i>	$\pm 1.0\%$
<i>Total Batch Weight Of</i>							
<i>Paving Mix. %</i>							
<i>Batch aggregate component</i>	$\pm 1.0\%$						
AASHTO T 164	<p>Method A APPARATUS: Section 6. ConnDOT in addition to AASHTO apparatus includes infrared lamp and substitutes graduated cylinder with a 1000 ml flask.</p> <p>Section 7. Reagent. Must be Conn D.O.T. approved *****</p> <p>Article 9.2.1 all classes of HMA except Class 4 are scooped from the sample container.</p> <p>Section 10.1 and 10.2 Moisture content is periodically determined on production samples as plant conditions require.</p> <p>Section 12.1 See Section 10</p> <p>Section 12.5 Filter paper is dried and weighed in field using heat lamp or oven when an ash test is performed.</p> <p>Article 12.6.1 Extract is collected if an ash test is to be performed</p> <p>Article 12.6.2 Performed on selected samples only</p>						

	Article 12.6.3 A three test running average is used to correct for total binder in HMA.
AASHTO T 168	<p>Samples are taken at one point in the pile. All types of bituminous concrete except Class 4 are scooped from the sample container instead of remixing and quartering. (Method verified by laboratory study).</p> <p>Samples from a hauling vehicle are taken from only one point instead of three as specified.</p> <p>Selection of Samples: Sampling is equally important as the testing, and the sampler shall use every precaution to obtain samples that are truly representative of the bituminous mixture.</p> <p>Box Samples: In order to enhance the rate of processing samples taken in the field by construction or maintenance personnel the samples will be tested in the order received and data processed to be determine conformance to material specifications and to prioritize inspections by laboratory personnel.</p>
AASHTO T 170	<p>Recovery of Asphalt from Solution by Abson Method</p> <p>Delete the referenced section and replace with the language shown:</p> <p>5.0 Apparatus</p> <p>5.1 Centrifuge- batch unit capable of exerting a minimum centrifugal force of 770 times gravity or a continuous unit capable of exerting a minimum force of 3000 times gravity.</p> <p>5.2. Centrifuge tubes- a 250mL wide mouth bottles</p> <p>5.3.1. Extraction Flasks- a 500mL three angle necks and joints flask with 24/40 side necks.</p> <p>5.3.2. Glass Tubing- Heat resistant glass tubing, having 10mm inside diameter and a gooseneck shaped delivery tube, for connecting the flask to the condenser.</p> <p>5.3.3. Inlet Aeration Tube- 180mm in length having a 6mm outside diameter with a 10-mm bulb carrying six staggered holes approximately 1.5 mm in diameter.</p> <p>5.3.4. Electric Heating Mantle- Variable transformer to fit a 500 mL flask.</p> <p>5.3.5 Water-jacketed Condenser- Allihn type, with 200 mm minimum jacket length.</p> <p>5.3.6. Thermometer- an ASTM low distillation thermometer having a range of -2 to 300°C (30 to 580°F), respectively, and conforming to the requirements in ASTM specification E 1</p> <p>5.3.7. Gas Flow Meter- A type capable of indicating a gas flow of up to 1000 mL per minute.</p> <p>5.3.8. Corks- No. 20</p> <p>5.3.9. Flexible Elastomeric Tubing</p> <p>5.3.10. Separatory Funnel-500 ml capacity or larger</p> <p>6.0. Reagents and Materials</p> <p>6.1. Carbon Dioxide Gas- A pressurized tank, with pressure-reducing valve. The solvent for extracting the asphalt from the mixtures should be reagent grade</p>

	<p>trichloroethylene or methylene chloride. Other solvents may affect the bitumen to change its properties significantly from that as it exists in the mixture.</p> <p>8. Sample</p> <p>8.1. The sample shall consist of the solution from previous extraction of a sample of sufficient mass to result in approximately 105 to 110 g of recovered bitumen.</p> <p>9. Procedure</p> <p>9.1. The entire procedure, from the start of the extraction to the final recovery, must be completed within 8 hours.</p> <p>9.2 Centrifuge the solution from the previous extraction for a minimum of 30 minutes at 770 times gravity (approx. 2700rpm) in 250 mL wide mouth bottles. Assemble the apparatus as shown in Figure 1 with the separatory funnel in the thermometer hole in the cork. Lower the aeration tube so that the bulb is in contact with the bottom of the flask. Fill the separatory funnel with the centrifuged solution and open the stopcock to fill the flask approximately one-half full of solvent mixture. Apply low heat to the flask and start distillation. Introduce carbon dioxide gas at a low rate (approx. 100mL/minute) to provide agitation and prevent foaming. Adjust the funnel stopcock to introduce fresh solvent at a rate that will keep the flask approximately one half full during distillation, adding additional solvent mixture to the funnel into all solvent has been introduced into the distillation flask. When the temperature reaches 157 to 160°C (315 to 320°F), increase the carbon dioxide gas flow to approximately 900mL/minute. Maintain this gas flow rate for 20 minutes while also maintaining the temperature of the residue in the flask at 160 to 166°C (320 to 330°F).</p>
<p>AASHTO T 195</p>	<p>Section 4.3 only one truck load of mixture is sampled. Samples are taken from opposite sides of the load.</p>
<p>AASHTO T 209</p>	<p>Article 9.5.1 Bowl is suspended 2 minutes prior to reading rather than 10 minutes. This makes no significant difference in results.</p> <p>Section 7.2 The average of two bowls is used proportionally in order to satisfy minimum mass requirements.</p> <p>8.3 Omit Pycnometer method.</p>
<p>AASHTO T 245</p>	<p>Article 3.3.2 A compacting temperature of 140 to 146°C (284 to 295°F) is used</p> <p>Article 3.5.2 Seventy-five (75) blows per side are used on Classes 1 and 12, per ConnDOT design requirements</p> <p>Section 3.1 for production testing: one specimen is molded for each extraction test for production over 275 metric tons/day (300 tons/day). Other mixtures: two specimens per extraction test.</p>

<p>AASHTO T 283</p>	<p>This protocol shall be performed at the HMA plant in accordance with section 7 on HMA S0.5 (all design levels) by the Contractor or their representative at a time designated by the Division Chief. TSR testing is required on all classes and design levels during the design phase and on all HMA S0.5 design levels during the production phase.</p>
<p>AASHTO T 308</p>	<p>In addition to the standard testing procedure, the Department has adopted a procedure that addresses a correction factor that is calculated using the composite aggregate percentages (Composite Aggregate Correction Factor Method (CACF)).</p> <p>The aggregate is burned in compliance with the standard AASHTO procedure Method A exclusively. All modifications are listed for this method only.</p> <p>A2.2 Omit A2.3 Omit A2.4 Omit. Replace with: Determine an aggregate gradation for each aggregate component “blank” in accordance with T30. A2.5 Omit. Replace with: The individual aggregate samples are to be dried in an oven at a maximum temperature of $148 \pm 5^{\circ}\text{C}$ ($300 \pm 9^{\circ}\text{F}$) to a constant weight. RAP samples are to be oven dried at a maximum temperature of $110 \pm 5^{\circ}\text{C}$ ($230 \pm 9^{\circ}\text{F}$) to a constant weight. RAP samples will be burned for total binder content only and not to arrive at a correction factor for a mixture. A2.6 Omit. A2.7 Omit A2.8 Omit A2.8.1 Omit Note 2 A2.9 Omit. Replace with: Perform a gradation analysis on the residual aggregate in accordance with T30 and compare it to the gradation performed prior to burning. A2.9.1 Omit A2.9.2 Omit</p> <p>The correction factors for each size aggregate are provided by the Contractor to the Engineer prior to the Annual Plant Inspection. The Composite Aggregate Correction Factor (CACF) for any mixture may be calculated by summing the result of the correction factor for each individual aggregate multiplied by the percentage of that aggregate in the overall mixture. (Note: All correction factors must be re-calculated every time the percentage of any aggregate changes within the mixture.)</p> <p>In addition to the standard testing procedure, the Department has adopted a procedure that addresses the time involved between sampling the hot mix asphalt specimen and the beginning of the test. 6.3 Omit. Replace with: The test specimen must be ready to be placed in an approved ignition furnace for testing within ten minutes of being obtained from the hauling vehicle and the test shall start immediately after.</p>

AASHTO T 331	6.1 Cores are dried to a constant mass prior to testing using a core-dry machine.
AASHTO Standard Recommended Practices	
Reference	Modification
AASHTO R 35	<p><u>Volumetric Calculations of VMA and Correction Factor</u> VMA_a - Voids in Mineral Aggregate from (V_a + V_be) the mix:</p> <p>A. VMA calculated from the mix shall be determined in accordance with <i>Formula 5.16.1A</i>. It can be correlated that the VMA calculated from AASHTO R-35 is equivalent to VMA_a when the $Pb_a \times (100 - Pb_t) / 100$ is known and substituted for A_{cf}, as shown in <i>Formula 5.16.1A (ii)</i>. Test results from VMA_a shall therefore be required to meet all contract specifications. Values of VMA_a that are out of specifications during production may be cause for the contractor to determine assignable reason, take corrective action, and modify the Job Mix Formula (JMF), as needed. Continued VMA_a data that is out of specifications may be cause for the Engineer to order cessation of supply.</p> <p><i>Formula 5.16.1A</i>. Determining the VMA of HMA by the mix or air voids & effective binder method:</p> $VMA_a = V_a + \left[\frac{(Gmb_d \times (Pb_t - A_{cf}))}{G_b} \right]$ <p>Where: VMA_a = VMA calculated from plant production mix(V_a + V_be) Gmb_d = Bulk specific gravity as determined by AASHTO T 166(M) Pb_t = Total Binder Content (corrected) by AASHTO T 308(M) A_{cf} = Absorption correction factor provided by Contractor (refer to B. i and ii)</p> <p>B. Determining the HMA mix binder correction factor for each class by use of percent absorption of water by AASHTO T 84/85, AASHTO M 323 and D_f method. This value shall be performed by the Contractor during the mix design only and submitted as a JMF value. Two methods for determining the A_{cf} are shown, although method (i) will be the desired method to be used. Both methods are equivalent when the G_{sa}, G_{sb} and P_{wa} are recent and valid for the mix.</p> <p style="margin-left: 40px;">i. $A_{cf} = Df \times Pwa \times (100 - Pb_t) / 100$</p> <p style="margin-left: 40px;">ii. $A_{cf} = (Pb_a \text{ from annual JMF submittal}) \times (100 - Pb_t) / 100$</p> <p>Where: D_f = as determined by Formula 5.16.1B. P_{wa} = as determined by AASHTO T 84/85 Pb_a = as determined by AASHTO M 323 (from annual JMF submittal) D_f (Density Factor): The Contractor shall calculate the HMA mix design D_f</p>

	<p>(derived from formula XI.2 APPENDIX XI of AASHTO R 35) for each class of material, in accordance with Formula 5.16.1B.</p> <p>Formula 5.16.1B. Determining the Density Factor (D_f) of mix design HMA:</p> $D_f = \left(\frac{G_{se} - G_{sb}}{G_{sa} - G_{sb}} \right)$ <p>Where: D_f = Density Factor or multiplier determined by AASHTO R-35(M) G_{se} = Effective Specific Gravity determined by AASHTO M-323 at plant G_{sa} = Apparent Specific Gravity determined by AASHTO T 84/85 of mix design G_{sb} = Bulk Specific Gravity determined by AASHTO T 84/85 of mix design</p>
<p>AASHTO R 26</p>	<p>Quality Control Plans must be formatted in accordance with AASHTO R 26, certifying suppliers of performance-graded asphalt binders, Section 9.0, Suppliers Quality Control Plan, and “NEAUPG Model PGAB QC Plan.”</p> <ol style="list-style-type: none"> 1. The Department requires that all laboratory technician(s) responsible for testing PG-binders be certified or Interim Qualified by the New England Transportation Technician Certification Program (NETTCP) as a PG Asphalt Binder Lab Technician. 2. Sampling of asphalt binders should be done under the supervision of qualified technician. NECTP “Manual of Practice,” Chapter 2 Page 2-4 (Key Issues 1-8). 3. A copy of the Manual of Practice for testing asphalt binders in accordance with the Superpave PG Grading system shall be in the testing laboratory. 4. All laboratories testing binders for the Department are required to be accredited by the AASHTO Materials Reference Laboratory (AMRL). 5. Sources interested in being approved to supply PG-binders to the Department by use of an “in-line blending system,” must record properties of blended material, and additives used. 6. Each source of supply of PG-binder must indicate that the binders contain no additives used to modify or enhance their performance properties. Binders that are manufactured using additives, modifiers, extenders etc., shall disclose the type of additive, percentage and any handling specifications/limitations required. <p>Suppliers shall provide AASHTO M-320 Table 2 testing at a minimum of once per month on one sample of material. Each supplier shall rotate the PG grade each month (including PMA), so that data can be collected for all the grades produced.</p>

D.B.E. SUBCONTRACTORS AND MATERIAL SUPPLIERS OR MANUFACTURERS

Revised – May 2000

NOTE: Certain of the requirements and procedures stated in this special provision are applicable prior to the award and execution of the contract document.

I. ABBREVIATIONS AND DEFINITIONS AS USED IN THIS SPECIAL PROVISION

- A. "CDOT" means the Connecticut Department of Transportation.
- B. "DOT" means the U.S. Department of Transportation, including the Office of the Secretary, the Federal Highway Administration ("FHWA"), the Federal Transit Administration ("FTA"), and the Federal Aviation Administration ("FAA").
- C. "Broker" is acting as an agent for others in negotiating contracts, agreements, purchases, sales, etc., in return for a fee or commission.
- D. "Contract," "agreement" or "subcontract" means a legally binding relationship obligating a seller to furnish supplies or services (including, but not limited to, construction and professional services) and the buyer to pay for them. For the purposes of this provision a lease for equipment or products is also considered to be a contract.
- E. "Contractor," means consultant, second party or any other entity doing business with CDOT or, as the context may require, with another contractor.
- F. "Disadvantaged Business Enterprise" ("DBE") means a small business concern:
 1. That is at least 51 percent owned by one or more individuals who are both socially and economically disadvantaged or, in the case of a corporation, in which 51 percent of the stock of which is owned by one or more such individuals; and
 2. Whose management and daily business operations are controlled by one or more of the socially and economically disadvantaged individuals who own it.
- G. "DOT-assisted contract" means any contract between a recipient and a contractor (at any tier) funded in whole or in part with DOT financial assistance, including letters of credit or loan guarantees.

- H. "Good Faith Efforts" means efforts to achieve a DBE goal or other requirement of this part which, by their scope, intensity, and appropriateness to the objective, can reasonably be expected to fulfill the program requirement. Refer to Appendix A of 49 CFR Part 26 – "Guidance Concerning Good Faith Efforts," a copy of which is attached to this provision, for guidance as to what constitutes good faith efforts.
- I. "Small Business Concern" means, with respect to firms seeking to participate as DBEs in DOT-assisted contracts, a small business concern as defined pursuant to Section 3 of the Small Business Act and Small Business Administration ("SBA") regulations implementing it (13 CFR Part 121) that also does not exceed the cap on average annual gross receipts specified in 49 CFR Part 26 Section 26.65(b).
- J. "Socially and Economically Disadvantaged Individuals" means any individual who is a citizen (or lawfully admitted permanent resident) of the United States and who is—
1. Any individual who CDOT finds on a case-by-case basis to be a socially and economically disadvantaged individual.
 2. Any individuals in the following groups, members of which are rebuttably presumed to be socially and economically disadvantaged:
 - i. "Black Americans," which includes persons having origins in any of the Black racial groups of Africa;
 - ii. "Hispanic Americans," which includes persons of Mexican, Puerto Rican, Cuban, Dominican, Central or South American, or other Spanish or Portuguese culture or origin, regardless of race;
 - iii. "Native Americans," which includes persons who are American Indians, Eskimos, Aleuts, or Native Hawaiians;
 - iv. "Asian-Pacific Americans," which includes persons whose origins are from Japan, China, Taiwan, Korea, Burma (Myanmar), Vietnam, Laos, Cambodia (Kampuchea), Thailand, Malaysia, Indonesia, the Philippines, Brunei, Samoa, Guam, the U.S. Trust Territories of the Pacific Islands (Republic of Palau), the Commonwealth of the Northern Marianas Islands, Macao, Fiji, Tonga, Kirbati, Juvalu, Nauru, Federated States of Micronesia, or Hong Kong;
 - v. "Subcontinent Asian Americans," which includes persons whose origins are from India, Pakistan, Bangladesh, Bhutan, the Maldives Islands, Nepal or Sri Lanka;
 - vi. Women;
 - vii. Any additional groups whose members are designated as socially and economically disadvantaged by the SBA, at such time as the SBA designation becomes effective.

II. GENERAL REQUIREMENTS

- A. The Contractor, sub recipient or subcontractor shall not discriminate on the basis of race, color, national origin, or sex in the performance of this Contract. The Contractor shall carry out applicable requirements of 49 CFR Part 26 in the award and administration of DOT-assisted contracts. Failure by the Contractor to carry out these requirements is a material breach of this Contract, which may result in the termination of this Contract or such other remedy, as the DOT deems appropriate.
- B. The Contractor shall cooperate with CDOT and DOT in implementing the requirements concerning DBE utilization on this contract in accordance with Title 49 of the Code of Federal Regulations, Part 26 entitled Participation by Disadvantaged Business Enterprises in Department of Transportation Financial Assistance Programs (“49 CFR Part 26”) as revised. The Contractor shall also cooperate with CDOT and DOT in reviewing the Contractor's activities relating to this provision. This Special Provision is in addition to all other equal opportunity employment requirements of this Contract.
- C. The Contractor shall designate a liaison officer who will administer the Contractor's DBE program. Upon execution of this contract, the name of the liaison officer shall be furnished to the Division of Contract Compliance of CDOT, in writing.
- D. For the purpose of this Special Provision, DBEs to be used to satisfy the DBE goal must be certified by CDOT's Division of Contract Compliance for the type(s) of work they will perform.
- E. If the Contractor allows work designated for DBE participation required under the terms of this Contract and required under Paragraph III-B to be performed by other than the named DBE organization without concurrence from the Office of Construction, CDOT will not pay the Contractor for the value of the work performed by organizations other than the designated DBE.
- F. At the completion of all Contract work, the Contractor shall submit a final report to CDOT's unit administering the Contract indicating the work done by, and the dollars paid to DBEs. If the Contractor does not achieve the specified Contract goals for DBE participation, the Contractor shall also submit written documentation to the CDOT unit administering the Contract detailing its good faith efforts to satisfy the goal that were made during the performance of the Contract. Documentation is to include but not be limited to the following:
 - 1. A detailed statement of the efforts made to select additional subcontracting opportunities to be performed by DBEs in order to increase the likelihood of achieving the stated goal.
 - 2. A detailed statement, including documentation of the efforts made to contact and solicit bids with CDOT certified DBEs, including the names, addresses, dates and telephone numbers of each DBE contacted, and a description of the information provided to each DBE regarding the scope of services and anticipated time schedule of work items proposed to be subcontracted and nature of response from firms contacted.

3. Provide a detailed statement for each DBE that submitted a subcontract proposal, which the Contractor considered not to be acceptable stating the reasons for this conclusion.
 4. Provide documents to support contacts made with CDOT requesting assistance in satisfying the Contract specified goal.
 5. Provide documentation of all other efforts undertaken by the Contractor to meet the defined goal.
- G. Failure of the Contractor at the completion of all Contract work to have at least the specified percentage of this Contract performed by DBEs as required in Paragraph III-B will result in the reduction in Contract payments to the Contractor by an amount determined by multiplying the total Contract value by the specified percentage required in Paragraph III-B and subtracting from that result, the dollar payments for the work actually performed by DBEs. However, in instances where the Contractor can adequately document or substantiate its good faith efforts made to meet the specified percentage to the satisfaction of CDOT, no reduction in payments will be imposed.
- H. All records must be retained for a period of three (3) years following acceptance by CDOT of the Contract and shall be available at reasonable times and places for inspection by authorized representatives of CDOT and Federal agencies. If any litigation, claim, or audit is started before the expiration of the three (3) year period, the records shall be retained until all litigation, claims, or audits findings involving the records are resolved.
- I. Nothing contained herein, is intended to relieve any Contractor or subcontractor or material supplier or manufacturer from compliance with all applicable Federal and State legislation or provisions concerning equal employment opportunity, affirmative action, nondiscrimination and related subjects during the term of this Contract.

III. SPECIFIC REQUIREMENTS:

In order to increase the participation of DBEs, CDOT requires the following:

- A. The Contractor shall assure that certified DBEs will have an opportunity to compete for subcontract work on this Contract, particularly by arranging solicitations, time for the preparation of proposals for services to be provided so as to facilitate the participation of DBEs regardless if a Contract goal is specified or not.
- B. Contract goal for DBE participation equaling 5 percent of the total Contract value has been established for this Contract. Compliance with this provision may be fulfilled when a DBE or any combination of DBEs perform work under contract in accordance with 49 CFR Part 26 Subpart C

Section 26.55, as revised. **Only work actually performed by and/or services provided by DBEs which are certified for such work and/or services can be counted toward the DBE goal. Supplies and equipment a DBE purchases or leases from the prime contractor or its affiliate can not be counted toward the goal.**

If the Contractor does not document commitments, by subcontracting and/or procurement of material and/or services that at least equal the goal, it must document the good faith efforts that outline the steps it took to meet the goal in accordance with VII.

- C. The low bidder shall indicate, in writing on the forms provided by CDOT, to the Manager of Contracts within 7 days after the bid opening, the DBE(s) it will use to achieve the goal indicated in III-B. The submission shall include the name and address of each DBE that will participate in this Contract, a description of the work each will perform, the dollar amount of participation, and the percentage this is of the bid amount. This information shall be signed by the named DBE and the low bidder. The named DBE shall be from a list of certified DBEs available from CDOT. **In addition, the named DBE(s) shall be certified to perform the type of work they will be contracted to do.**
- D. The prime Contractor shall submit to the Manager of Construction Operations all requests for subcontractor approvals on the standard forms provided by CDOT.

If the request for approval is for a DBE subcontractor for the purpose of meeting the Contract DBE goal, a copy of the legal contract between the prime and the DBE subcontractor must be submitted along with the request for subcontractor approval. Any subsequent amendments or modifications of the contract between the prime and the DBE subcontractor must also be submitted to the Manager of Construction Operations with an explanation of the change(s). The contract must show items of work to be performed, unit prices and, if a partial item, the work involved by all parties.

In addition, the following documents are to be attached:

1. An explanation indicating who will purchase material.
 2. A statement explaining any method or arrangement for renting equipment. If rental is from a prime, a copy of the Rental Agreement must be submitted.
 3. A statement addressing any special arrangements for manpower.
- E. The Contractor is required, should there be a change in a DBE they submitted in III-C, to submit documentation to CDOT's Office of Construction which will substantiate and justify the change, (i.e., documentation to provide a basis for the change for review and approval by CDOT's Office of Construction) prior to the implementation of the change. The Contractor must demonstrate that the originally named DBE is unable to perform in conformity to the scope of service or is unwilling to perform, or is in default of its contract, or is overextended on other jobs. **The Contractor's ability to negotiate a more advantageous agreement with another**

subcontractor is not a valid basis for change. Documentation shall include a letter of release from the originally named DBE indicating the reason(s) for the release.

- F. Contractors subcontracting with DBEs to perform work or services as required by this Special Provision shall not terminate such firms without advising CDOT's Office of Construction in writing, and providing adequate documentation to substantiate the reasons for termination if the DBE has not started or completed the work or the services for which it has been contracted to perform.
- G. When a DBE is unable or unwilling to perform or is terminated for just cause the contractor shall make good faith efforts to find other DBE opportunities to increase DBE participation to the extent necessary to at least satisfy the goal required by III-B.
- H. In instances where an alternate DBE is proposed, a revised submission to CDOT's Office of Construction together with the documentation required in III-C, III-D, and III-E, must be made for its review and approval.
- I. Each quarter after execution of the Contract, the Contractor shall submit a report to CDOT's unit administering the Contract indicating the work done by, and the dollars paid to the DBE for the current quarter and to date.

IV. MATERIAL SUPPLIERS OR MANUFACTURERS

- A. If the Contractor elects to utilize a DBE supplier or manufacturer to satisfy a portion or all of the specified DBE goal, the Contractor must provide the CDOT with:
 - 1. An executed Affidavit "Connecticut Department of Transportation (Office of Construction) Bureau of Highway" (sample attached), and
 - 2. Substantiation of payments made to the supplier or manufacturer for materials used on the project.
- B. Credit for DBE suppliers is limited to 60% of the value of the material to be supplied, provided such material is obtained from a regular DBE dealer. A regular dealer is a firm that owns, operates, or maintains a store, warehouse or other establishment in which the materials or supplies required for the performance of the contract are bought, kept in stock and regularly sold or leased to the public in the usual course of business. To be a regular dealer, the firm must engage in, as its principal business, and in its own name, the purchase and sale of the products in question. A regular dealer in such bulk items as steel, cement, gravel, stone and petroleum products, need not keep such products in stock if it owns or operates distribution equipment. Brokers and packagers shall not be regarded as material suppliers or manufacturers.
- C. Credit for DBE manufacturers is 100% of the value of the manufactured product. A manufacturer is a firm that operates or maintains a factory or establishment that produces on the premises the materials or supplies obtained by the Department of Transportation or contractor.

V. NON-MANUFACTURING OR NON-SUPPLIER DBE CREDIT:

Contractors may count towards its DBE goals the following expenditures with DBEs that are not manufacturers or suppliers:

1. Reasonable fees or commissions charged for providing a bona fide service such as professional, technical, consultant or managerial services and assistance in the procurement of essential personnel, facilities, equipment materials or supplies necessary for the performance of the contract provided that the fee or commission is determined by the CDOT to be reasonable and consistent with fees customarily allowed for similar services.
2. The fees charged for delivery of materials and supplies required on a job site (but not the cost of the materials and supplies themselves) when the hauler, trucker, or delivery service is a DBE but is not also the manufacturer of or a regular dealer in the materials and supplies, provided that the fee is determined by the CDOT to be reasonable and not excessive as compared with fees customarily allowed for similar services.
3. The fees or commissions charged for providing bonds or insurance specifically required for the performance of the contract, provided that the fee or commission is determined by the CDOT to be reasonable and not excessive as compared with fees customarily allowed for similar services.

VI. BROKERING

- A. Brokering of work by DBEs who have been approved to perform subcontract work with their own workforce and equipment is not allowed, and is a contract violation.
- B. DBEs involved in the brokering of subcontract work that they were approved to perform may be decertified.
- C. Firms involved in the brokering of work, whether they are DBEs and/or majority firms who engage in willful falsification, distortion or misrepresentation with respect to any facts related to the project shall be referred to the U.S. Department of Transportation's Office of the Inspector General for prosecution under Title 18, U.S. Code, Section 10.20.

VII. REVIEW OF PRE-AWARD GOOD FAITH EFFORTS

- A. If the Contractor does not document pre-award commitments, by subcontracting and/or procurement of material and/or services that at least equal the goal stipulated in III-B, the Contractor must document the good faith efforts that outline the specific steps it took to meet the

goal. The Contract will be awarded to the Contractor if its good faith efforts are deemed satisfactory and approved by CDOT. To obtain such an exception, the Contractor must submit an application to CDOT's Manager of Contracts, which documents the specific good faith efforts that were made to meet the DBE goal. Application forms for Review of Pre-Award Good Faith Efforts are available from CDOT's Division of Contract Administration.

The application must include the following documentation:

1. a statement setting forth in detail which parts, if any, of the contract were reserved by the contractor and not available for bid from subcontractors;
2. a statement setting forth all parts of the contract that are likely to be sublet.
3. a statement setting forth in detail the efforts made to select subcontracting work in order to likely achieve the stated goal.
4. copies of all letters sent to DBEs;
5. a statement listing the dates and DBEs that were contacted by telephone and the result of each contact;
6. a statement listing the dates and DBEs that were contacted by other means other than telephone and the result of each contact;
7. copies of letters received from DBEs in which they decline to bid;
8. a statement setting forth the facts with respect to each DBE bid received and the reason(s) any such bid was declined;
9. a statement setting forth the dates that calls were made to CDOT's Division of Contract Compliance seeking DBE referrals and the result of each such call; and
10. any information of a similar nature relevant to the application.

The review of the Contractor's good faith efforts may require an extension of time for award of the Contract. In such a circumstance and in the absence of other reasons not to grant the extension or make the award CDOT will agree to the needed extension(s) of time for the award of the Contract, provided the Contractor and the surety also agree to such extension(s).

- B. Upon receipt of the submission of an application for review of pre-award good faith efforts, CDOT's Manager of Contracts shall submit the documentation to the Division of Contract Compliance who will review the documents and determine if the package is complete and accurate and adequately documents the Contractor's good faith efforts. Within 14 days of receipt of the documentation the

Division of Contract Compliance shall notify the Contractor by certified mail of the approval or denial of its good faith efforts.

- C. If the Contractor's application is denied, the Contractor shall have seven (7) days upon receipt of written notification of denial to request administrative reconsideration. The Contractor's request for administrative reconsideration should be sent in writing to: Manager of Contracts, P.O. Box 317546, Newington, CT 06131-7546. The Manager of Contracts will forward the Contractor's reconsideration request to the DBE Screening Committee. The DBE Screening Committee will schedule a meeting within 14 days from receipt of the Contractor's request for administrative reconsideration and advise the Contractor of the date, time and location of the meeting. At this meeting the Contractor will be provided with the opportunity to present written documentation and/or argument concerning the issue of whether it made adequate good faith efforts to meet the goal. Within seven (7) days following the reconsideration meeting, the chairperson of the DBE Screening Committee will send the contractor via certified mail a written decision on its reconsideration request, explaining the basis of finding either for or against the request. **If the reconsideration is denied the Contractor shall indicate in writing to the Manager of Contracts within 14 days of receipt of written notification of denial, the DBEs it will use to achieve the goal indicated in III-B.**
- D. Approval of pre-award good faith efforts does not relieve the Contractor from its obligation to make additional good faith efforts to achieve the DBE goal should contracting opportunities arise during actual performance of the Contract work.

APPENDIX A TO 49 CFR PART 26 -- GUIDANCE CONCERNING GOOD FAITH EFFORTS

- I. When, as a recipient, you establish a contract goal on a DOT-assisted contract, a bidder must, in order to be responsible and/or responsive, make good faith efforts to meet the goal. The bidder can meet this requirement in either of two ways. First, the bidder can meet the goal, documenting commitments for participation by DBE firms sufficient for this purpose. Second, even if it doesn't meet the goal, the bidder can document adequate good faith efforts. This means that the bidder must show that it took all necessary and reasonable steps to achieve a DBE goal or other requirement of this part which, by their scope, intensity, and appropriateness to the objective, could reasonably be expected to obtain sufficient DBE participation, even if they were not fully successful.
- II. In any situation in which you have established a contract goal, part 26 requires you to use the good faith efforts mechanism of this part. As a recipient, it is up to you to make a fair and reasonable judgment whether a bidder that did not meet the goal made adequate good faith efforts. It is important for you to consider the quality, quantity, and intensity of the different kinds of efforts that the bidder has made. The efforts employed by the bidder should be those that one could reasonably expect a bidder to take if the bidder were actively and aggressively trying to obtain DBE participation sufficient to meet the DBE contract goal. Mere pro forma efforts are not good faith efforts to meet the DBE contract requirements. We emphasize, however, that your determination concerning the sufficiency of the firm's good faith efforts is a judgment call: meeting quantitative formulas is not required.
- III. The Department also strongly cautions you against requiring that a bidder meet a contract goal (i.e., obtain a specified amount of DBE participation) in order to be awarded a contract, even though the bidder makes an adequate good faith efforts showing. This rule specifically prohibits you from ignoring bona fide good faith efforts.
- IV. The following is a list of types of actions which you should consider as part of the bidder's good faith efforts to obtain DBE participation. It is not intended to be a mandatory checklist, nor is it intended to be exclusive or exhaustive. Other factors or types of efforts may be relevant in appropriate cases.
 - A. Soliciting through all reasonable and available means (e.g. attendance at pre-bid meetings, advertising and/or written notices) the interest of all certified DBEs who have the capability to perform the work of the contract. The bidder must solicit this interest within sufficient time to allow the DBEs to respond to the solicitation. The bidder must determine with certainty if the DBEs are interested by taking appropriate steps to follow up initial solicitations.
 - B. Selecting portions of the work to be performed by DBEs in order to increase the likelihood that the DBE goals will be achieved. This includes, where appropriate, breaking out contract work items into economically feasible units to facilitate DBE

- participation, even when the prime contractor might otherwise prefer to perform these work items with its own forces.
- C. Providing interested DBEs with adequate information about the plans, specifications, and requirements of the contract in a timely manner to assist them in responding to a solicitation.
 - D. (1) Negotiating in good faith with interested DBEs. It is the bidder's responsibility to make a portion of the work available to DBE subcontractors and suppliers and to select those portions of the work or material needs consistent with the available DBE subcontractors and suppliers, so as to facilitate DBE participation. Evidence of such negotiation includes the names, addresses, and telephone numbers of DBEs that were considered; a description of the information provided regarding the plans and specifications for the work selected for subcontracting; and evidence as to why additional agreements could not be reached for DBEs to perform the work.
 - (2) A bidder using good business judgment would consider a number of factors in negotiating with subcontractors, including DBE subcontractors, and would take a firm's price and capabilities as well as contract goals into consideration. However, the fact that there may be some additional costs involved in finding and using DBEs is not in itself sufficient reason for a bidder's failure to meet the contract DBE goal, as long as such costs are reasonable. Also, the ability or desire of a prime contractor to perform the work of a contract with its own organization does not relieve the bidder of the responsibility to make good faith efforts. Prime contractors are not, however, required to accept higher quotes from DBEs if the price difference is excessive or unreasonable.
 - E. Not rejecting DBEs as being unqualified without sound reasons based on a thorough investigation of their capabilities. The contractor's standing within its industry, membership in specific groups, organizations, or associations and political or social affiliations (for example union vs. non-union employee status) are not legitimate causes for the rejection or non-solicitation of bids in the contractor's efforts to meet the project goal.
 - F. Making efforts to assist interested DBEs in obtaining bonding, lines of credit, or insurance as required by the recipient or contractor.
 - G. Making efforts to assist interested DBEs in obtaining necessary equipment, supplies, materials, or related assistance or services.
 - H. Effectively using the services of available minority/women community organizations; minority/women contractors' groups; local, state, and Federal minority/women business assistance offices; and other organizations as allowed on a case-by-case basis to provide assistance in the recruitment and placement of DBEs.

- V. In determining whether a bidder has made good faith efforts, you may take into account the performance of other bidders in meeting the contract. For example, when the apparent successful bidder fails to meet the contract goal, but others meet it, you may reasonably raise the question of whether, with additional reasonable efforts, the apparent successful bidder could have met the goal. If the apparent successful bidder fails to meet the goal, but meets or exceeds the average DBE participation obtained by other bidders, you may view this, in conjunction with other factors, as evidence of the apparent successful bidder having made good faith efforts.

**CONNECTICUT DEPARTMENT OF TRANSPORTATION
(OFFICE OF CONSTRUCTION)
BUREAU OF ENGINEERING AND HIGHWAY OPERATIONS**

This affidavit must be completed by the State Contractor's DBE notarized and attached to the contractor's request to utilize a DBE supplier or manufacturer as a credit towards its DBE contract requirements; failure to do so will result in not receiving credit towards the contract DBE requirement.

State Project No.

Federal Aid Project No.

Description of Project

I, _____, acting in behalf of _____
(Name of person signing Affidavit) (DBE person, firm, association or corporation)
of which I am the _____ certify and affirm that _____
(Title of Person) (DBE person, firm, association or corporation)

is a certified Connecticut Department of Transportation DBE. I further certify and affirm that I have read and understand 49 CFR, Sec. 26.55(e)(2), as the same may be revised.

I further certify and affirm that _____ will assume the actual and
(DBE person, firm, association or Corporation)

for the provision of the materials and/or supplies sought by _____
(State Contractor)

If a manufacturer, I produce goods from raw materials or substantially alter them before resale, or if a supplier, I perform a commercially useful function in the supply process.

I understand that false statements made herein are punishable by Law (Sec. 53a-157), CGS, as revised).

(Name of Corporation or Firm)

(Signature & Title of Official making the Affidavit)

Subscribed and sworn to before me, this _____ day of _____ 20 _____.

Notary Public (Commissioner of the Superior Court)

My Commission Expires

CERTIFICATE OF CORPORATION

I, _____, certify that I am the
(Official)

of the Corporation named in the foregoing instrument; that I have been duly authorized to affix the seal of the Corporation to such papers as require the seal; that _____, who signed said instrument on behalf of the Corporation, was then of said corporation; that said instrument was duly signed for and in behalf of said Corporation by authority of its governing body and is within the scope of its corporation powers.

(Signature of Person Certifying)

(Date)

ITEM #0921001A - CONCRETE SIDEWALK

Concrete sidewalks shall be constructed in accordance with Article 9.21, supplemented as follows:

Article 9.21.01 - Description: Add the following:

This item shall include furnishing and installing Detectable Warning Strips in the locations and to the dimensions and details shown on the plans or as ordered by the Engineer.

Article 9.21.02 – Materials: Add the following:

The Detectable Warning Strip shall be a prefabricated detectable warning surface tile as manufactured from Engineered Plastics Inc. 300 International Drive, Suite 100 Williamsville, NY 14221, telephone number (800) 682-2525 or the approved equal from ADA Fabricators, INC. P.O Box 179 North Billerica, MA 01862 telephone number (978) 262-9900. The tile shall conform to the dimensions shown on the plans and have a brick red homogeneous color throughout in compliance with Federal Standard 595A Color #22144 or approved equal.

Article 9.21.03 – Construction Methods: Add the following:

The Detectable Warning Strip for new construction shall be set directly in poured concrete according to the plans and the manufacturer's specifications or as directed by the Engineer. The contractor shall place two 25 pound concrete blocks or sandbags on each tile to prevent the tile from floating after installation in wet concrete.

Article 9.21.04 - Method of Measurement: Add the following:

The Detectable Warning strip will not be measured for payment. All materials, equipment, tools and labor incidental thereto shall be included in the Bid price for Concrete Sidewalk.

ITEM #0925101A - RELAY BRICK WALK

Description:

Work under this item shall consist of removing and reconstructing brick walk which has been disturbed by excavation at the locations shown on the plans or as directed by the Engineer in conformance with these specifications.

Materials:

Gravel for base shall conform to Article M.02.01 for gravel fill. Leveling base material shall be concrete sand conforming to ASTM C-33 for fine aggregates or No. 10 as shown in AASHTO M 43-54 (1974) as specified in table II.

Construction Methods:

Existing bricks shall be carefully removed. If any bricks are broken during removal, the Contractor shall be responsible for replacing them. Upon reconstruction of the brick walk, all soft and yielding material and other portions of the subbase which will not readily compact shall be removed and replaced with suitable materials. The surface of the subbase shall be compacted with mechanical equipment capable of delivering a ground pressure of not less than 300 pounds per linear inch (54 kilograms per linear centimeter) of contact width. The amount of compaction shall be as specified by the Engineer but in no case shall that amount be less than four complete passes of the compacting equipment. The dry density after compaction shall conform to Article 2.02.03-6 of the standard specifications, Form 816. After compaction, the subbase shall be trued to the required line and grade. No additional payment will be made for any materials which are required to bring the subbase to the lines, grade and cross-sections of the site. The Contractor shall protect the subbase from damage by exercising such precautions as the Engineer deems necessary. The subbase surface shall be maintained in such condition as to permit proper drainage. It shall be checked and approved prior to placement of the leveling base. The leveling base shall be screeded loose to a thickness of approximately 2" (50mm). The leveling shall be treated with a soil sterilizer, of a type to be approved by the Engineer, prior to the placement of the bricks. The exact thickness of the leveling base is to be determined at the job site.

Care shall be taken by the Contractor to insure the screeded leveling base is loose and undisturbed placement. Bricks are to be installed "Hand-tight" with care being taken not to disturb the leveling bed. Mason string lines shall be used to insure proper lines and grades. Bricks are to be vibrated into the leveling base with a vibratory plate capable of achieving a 3500 to 5000 pounds (1590 to 2268 kilograms) compaction force. Such vibratory compaction shall be accomplished on all bricks prior to the end of operations on each working day. Compaction of the bricks shall continue until finish grade, as directed by the Engineer, is achieved. All joints shall be filled after final compaction with the same material used for the leveling base.

Method of Measurement:

This work will be measured for payment by the actual number of square feet (square meters) of complete and accepted relayed brick walk.

Basis of Payment:

This work will be paid for at the contract unit price per square foot (square meter) for "Relay Brick Walk" complete and accepted in place which price shall include removing, storing and reconstruction of Brick Walk and all material, labor, equipment and work incidental thereto.

ITEM #0952001A – SELECTIVE CLEARING AND THINNING

Section 9.52 is amended as follows:

Article 9.52.03 – Construction Methods is supplemented as follows:

Where directed by the Engineer, materials to be cut, trimmed or removed shall be those items that restrict continuous visibility to traffic signal faces approaching a signalized intersection to less than the minimum sight distance required for the 85th percentile speed based on Table 4D-2 in the 2009 Edition of the FHWA's Manual on Uniform Traffic Control Devices.

ITEM #0970006A - TRAFFICPERSON (MUNICIPAL POLICE OFFICER)
ITEM #0970007A - TRAFFICPERSON (UNIFORMED FLAGGER)

9.70.01—Description: Under this item the Contractor shall provide the services of Trafficpersons of the type and number, and for such periods, as the Engineer approves for the control and direction of vehicular traffic and pedestrians. Traffic persons requested solely for the contractor's operational needs will not be approved for payment.

9.70.03—Construction Method: On a weekly basis, the Contractor shall inform the Engineer of their scheduled operations for the following week and the number of Trafficpersons requested. The Engineer shall review this schedule and approve the type and number of Trafficpersons required.

If the Contractor changes or cancels any scheduled operations without prior notice of same as required by the agency providing the Trafficpersons, and such that Trafficperson services are no longer required, the Contractor will be responsible for payment at no cost to the Department of any show-up cost for any Trafficperson not used because of the change. Exceptions, as approved by the Engineer, may be granted for adverse weather conditions and unforeseeable causes beyond the control and without the fault or negligence of the Contractor.

Trafficpersons assigned to a work site are to only take direction from the Engineer.

Trafficpersons shall wear a high visibility safety garment that complies with OSHA, MUTCD, ASTM Standards and the safety garment shall have the words "Traffic Control" clearly visible on the front and rear panels (minimum letter size 2 inches (50 millimeters)). Worn/faded safety garments that are no longer highly visible shall not be used. The Engineer shall direct the replacement of any worn/faded garment at no cost to the State.

A Trafficperson shall assist in implementing the traffic control specified in the Maintenance and Protection of Traffic contained elsewhere in these specifications or as directed by the Engineer. Any situation requiring a Trafficperson to operate in a manner contrary to the Maintenance and Protection of Traffic specification shall be authorized in writing by the Engineer.

Prior to the start of operations on the project requiring the use of Trafficpersons, a meeting will be held with the Contractor, Trafficperson agency or firm, and Engineer to review the Trafficperson operations, lines of responsibility, and operating guidelines which will be used on the project. A copy of the municipality's billing rates for Municipal Police Officers and vehicles, if applicable, will be provided to the Engineer prior to start of work. In the event of an unplanned, emergency, or short term operation, the Engineer may approve the temporary use of properly clothed persons for traffic control until such time as an authorized Trafficperson may be obtained. In no case shall this temporary use exceed 8 hours for any particular operation.

Trafficpersons shall consist of the following types:

1. Uniformed Law Enforcement Personnel: Law enforcement personnel shall wear the high visibility safety garment provided by their law enforcement agency. If no high visibility safety garment is provided, the Contractor shall provide the law enforcement personnel with a garment meeting the requirements stated below for the Uniformed Flaggers' garment.

Law Enforcement Personnel may be also be used to conduct motor vehicle enforcement operations in and around work areas as directed and approved by the Engineer.

A. State Police Officer: State Police Officers shall be uniformed off-duty sworn Connecticut State Police Officers. Their services will also include the use of official State Police vehicles and associated equipment.

State Police Officers will be used on all limited access highways. State Police Officers will not be used on non-limited access highways unless specifically under their jurisdiction or authorized in writing by the Engineer. State Police Officers with official State Police vehicles will be used at such locations and for such periods as the Engineer deems necessary to control traffic operations and promote increased safety to motorists through the construction sites. On limited access highways, the Engineer may determine that State Police Officers will be utilized for regional work zone traffic safety and enforcement operations in addition to project-related work zone assignments.

B. Municipal Police Officers: Uniformed Municipal Police Officers shall be sworn Municipal Police Officers or Uniformed Constables who perform criminal law enforcement duties from the Municipality in which the project is located. Their services will also include an official Municipal Police vehicle when requested by the Engineer. Uniformed Municipal Police Officers will be used on non-limited access highways. If Uniformed Municipal Police Officers are unavailable, other Trafficpersons may be used when authorized in writing by the Engineer. Uniformed Municipal Police Officers and requested Municipal Police vehicles will be used at such locations and for such periods as the Engineer deems necessary to control traffic operations and promote increased safety to motorists through the construction sites.

2. Uniformed Flagger: Uniformed Flaggers shall be persons who have successfully completed flagger training by the American Traffic Safety Services Association (ATTSA), National Safety Council (NSC) or other programs approved by the Engineer. A copy of the Flagger's training certificate shall be provided to the Engineer before the Flagger performs any work on the project. Uniformed Flaggers shall conform to Chapter 6E, Flagger Control, in the Manual of Uniformed Traffic Control Devices (MUTCD) and shall wear high-visibility safety apparel, use a STOP/SLOW paddle that is at least 18 inches (450 millimeters) in width with letters at least 6 inches (150 millimeters) high. The paddle shall be mounted on a pole of sufficient length to be 6 feet (1.8 meters) above the ground as measured from the bottom of the sign.

Uniformed Flaggers will only be used on non-limited access highways to control traffic operations when authorized in writing by the Engineer.

9.70.04—Method of Measurement: Services of Trafficpersons will be measured for payment by the actual number of hours for each person rendering services approved by the Engineer. These services shall include, however, only such trafficpersons as are employed within the limits of construction, project right of way of the project or along detours authorized by the Engineer to assist the motoring public through the construction work zone. Services for continued use of a detour or bypass beyond the limitations approved by the Engineer, for movement of construction vehicles and equipment, or at locations where traffic is unnecessarily restricted by the Contractor's method of operation, will not be measured for payment.

Trafficpersons shall not work more than twelve hours in any one 24 hour period. In case such services are required for more than twelve hours, additional Trafficpersons shall be furnished and measured for payment. In cases where the Trafficperson is an employee on the Contractor's payroll, payment under the item "Trafficperson (Uniformed Flagger)" will be made only for those hours when the Contractor's employee is performing Trafficperson services.

Travel time charged by State Police Officers, will be measured for payment. The maximum amount to be measured for payment will be one hour per shift per assignment. Officers splitting assignments in a shift shall only be given one half hour each.

Travel time will not be measured for payment for services provided by Uniformed Municipal Police Officers or Uniformed Flaggers.

Mileage fees associated with Trafficperson services will not be measured for payment.

Safety garments and STOP/SLOW paddles will not be measured for payment.

9.70.05—Basis of Payment: Trafficpersons will be paid in accordance with the schedule described herein.

There will be no direct payment for safety garments or STOP/SLOW paddles. All costs associated with furnishing safety garments and STOP/SLOW paddles shall be considered included in the general cost of the item.

1. Uniformed Law Enforcement Personnel: The sum of money shown on the Estimate and in the itemized proposal as "Estimated Cost" for this work will be considered the bid price even though payment will be made as described below. The estimated cost figure is not to be altered in any manner by the bidder. Should the bidder alter the amount shown, the altered figures will be disregarded and the original price will be used to determine the total amount for the contract.

The Department will pay the Contractor its actual costs for "Trafficperson (State Police Officer)" and "Trafficperson (Municipal Police Officer)" plus an additional 5% as reimbursement for the Contractor's administrative expense in connection with the services provided.

Payment, not to exceed 80%, will be made to the Contractor based on an approved invoice for services provided. Remaining payment and the 5% administrative expense will be paid once the receipted bill or cancelled check is submitted to the Engineer.

The invoice must include a breakdown of each officer's actual hours of work and actual rate applied. Mileage fees associated with Trafficperson services are not reimbursable expenses and are not to be included in the billing invoice. The use of a municipal police vehicle authorized by the Engineer will be paid at the actual rate charged by the municipality. The invoice will be reviewed and approved by the Engineer prior to any payments. The rate charged by the municipality for use of a uniformed municipal police officer and/or a municipal police vehicle shall not be greater than the rate it normally charges others for similar services.

2. Uniformed Flagger: Uniformed flaggers will be paid for at the contract unit price per hour for "Trafficperson (Uniformed Flagger)", which price shall include all compensation, insurance benefits and any other cost or liability incidental to the furnishing of the trafficpersons ordered.

Pay Item	Pay Unit
Trafficperson (State Police Officer)	est.
Trafficperson (Municipal Police Officer)	est.
Trafficperson (Uniformed Flagger)	Hr.

ITEM #0971001A – MAINTENANCE AND PROTECTION OF TRAFFIC

Article 9.71.01 – Description is supplemented by the following:

The Contractor shall maintain and protect traffic as follows and as limited in the Special Provision "Prosecution and Progress":

The Contractor shall maintain and protect existing traffic operations.

Excepted therefrom will be those periods, during the allowable periods, when the Contractor is actively working, at which time the Contractor shall maintain and protect on at least one lane of through traffic in each direction on a paved travel path not less than 11 feet in width.

Excepted therefrom will be those periods, during the allowable periods, when the Contractor is actively working on installing loop detectors or hanging signal heads, at which time the contractor shall maintain and protect at least an alternating one-way traffic operation on a paved travel path not less than 12 feet in width. The length of alternating one-way traffic operation shall not exceed 300 feet in length.

Excepted therefrom will be those periods, during the allowable periods, when the Contractor is actively working on installing spans or mast arms, at which time the Contractor will be permitted to halt traffic for a period not to exceed ten minutes. The Contractor shall allow all stored vehicles to proceed through the work area before halting traffic for another ten-minute period.

COMMERCIAL AND RESIDENTIAL DRIVEWAYS

The Contractor shall maintain access to and egress from all commercial and residential driveways throughout the project limits. The Contractor will be allowed to close said driveways to perform the required work during those periods when the businesses are closed unless permission is granted from the business owner to close the driveway during business hours. If a temporary closure of a residential driveway is necessary, the Contractor shall coordinate with the owner to determine the time period of the closure.

Article 9.71.03 - Construction Method is supplemented as follows:

SIGNING

The Contractor shall maintain all existing overhead and side-mounted signs throughout the project limits during the duration of the project. The Contractor shall temporarily relocate existing signs and sign supports as many times as deemed necessary and install temporary sign supports and foundations if necessary and as directed by the Engineer. The temporary relocation of any existing signs and supports, and the furnishing, installation and removal of any temporary

supports and foundations, shall be paid for under the item “Maintenance and Protection of Traffic.”

When all work is completed, the Contractor shall remove existing signs and install new signs as shown on the Signing and Pavement Marking Plans contained in the contract plans.

TRAFFIC SIGNALS

The Contractor shall keep each traffic signal in the project limits operational at all times during construction in accordance with the Special Provision “Temporary Signalization.”

The Contractor shall install final pavement markings and signing prior to the proposed traffic signal being made fully operational.

REQUIREMENTS FOR WINTER

The Contractor shall schedule a meeting with representatives of the Engineer, Maintenance, and Traffic to determine what interim traffic control measures the Contractor must accomplish for the winter to provide safety to the motorist and permit adequate snow removal procedures.

SIGNING PATTERNS

The Contractor shall erect and maintain all signing patterns in accordance with the traffic control plans contained herein. Proper distances between advance warning signs and proper taper lengths are mandatory.

Pavement Markings - Limited Access Highways, Turning Roadways and Ramps

During construction, the Contractor shall maintain all pavement markings throughout the limits of the project.

Interim Pavement Markings

The Contractor shall install painted pavement markings, which shall include lane lines (broken lines), shoulder edge lines, stop bars, lane-use arrows and gore markings, on each intermediate course of bituminous concrete pavement and on any milled surface by the end of the work day/night. All painted pavement markings will be paid under the appropriate items.

If the Contractor does not install permanent Epoxy Resin Pavement Markings by the end of the work day/night on exit ramps where the final course of bituminous concrete pavement has been installed, the Contractor shall install temporary 12 inch wide white stop bars. The temporary stop bars shall consist of Temporary Plastic Pavement Marking Tape and shall be installed by the end of the work day/night. Stop bars may consist of two 6 inch wide white markings or three 4 inch wide white markings placed side by side. The Contractor shall remove and dispose of these markings when the permanent Epoxy Resin Pavement Markings are installed. The cost of furnishing, installing and removing the Temporary Plastic Pavement Marking Tape shall be at the Contractor's expense.

If an intermediate course of bituminous concrete pavement will be exposed throughout the winter, then Epoxy Resin Pavement Markings should be installed unless directed otherwise by the Engineer.

Final Pavement Markings

In accordance with the Special Provision contained elsewhere in the contract documents, the Contractor shall install inlaid Plastic Pavement Markings at the time of installation of the final course of bituminous concrete pavement.

In accordance with Section 12.10 entitled "Epoxy Resin Pavement Markings, Symbols and Legends," the Contractor should install permanent Epoxy Resin Pavement Markings on the final course of bituminous concrete pavement by the end of the work day/night. If the permanent pavement markings are not installed by the end of the work day/night, then temporary stop bars shall be installed as described above and the permanent Epoxy Resin Pavement Markings shall be installed by the end of the work day/night on Friday of that week.

NOTE: Painted pavement markings will not be allowed as a substitution for either the permanent inlaid Plastic Pavement Markings or the permanent Epoxy Resin Pavement Markings on the final course of bituminous concrete pavement.

Pavement Markings -Non-Limited Access Multilane Roadways
Secondary and Local Roadways

During construction, the Contractor shall maintain all pavement markings on paved surfaces on all roadways throughout the limits of the project.

Interim Pavement Markings

The Contractor shall install painted pavement markings, which shall include centerlines, shoulder edge lines, lane lines (broken lines), lane-use arrows, and stop bars, on each intermediate course of bituminous concrete pavement and on any milled surface by the end of the work day/night. If the next course of bituminous concrete pavement will be placed within seven days, shoulder edge lines are not required. The painted pavement markings will be paid under the appropriate items.

If the Contractor will install another course of bituminous concrete pavement within 24 hours, the Contractor may install Temporary Plastic Pavement Marking Tape in place of the painted pavement markings by the end of the work day/night. These temporary pavement markings shall include centerlines, lane lines (broken lines) and stop bars; shoulder edge lines are not required. Centerlines shall consist of two 4 inch wide yellow markings, 2 feet in length, side by side, 4 to 6 inches apart, at 40-foot intervals. No passing zones should be posted with signs in those areas where the final centerlines have not been established on two-way roadways. Stop bars may consist of two 6 inch wide white markings or three 4 inch wide white markings placed side by side. The Contractor shall remove and dispose of the Temporary Plastic Pavement Marking Tape when another course of bituminous concrete pavement is installed. The cost of furnishing, installing and removing the Temporary Plastic Pavement Marking Tape shall be at the Contractor's expense.

If an intermediate course of bituminous concrete pavement will be exposed throughout the winter, then Epoxy Resin Pavement Markings should be installed unless directed otherwise by the Engineer.

Final Pavement Markings

In accordance with Section 12.10 entitled "Epoxy Resin Pavement Markings, Symbols, and Legends," the Contractor should install permanent Epoxy Resin Pavement Markings on the final course of bituminous concrete pavement by the end of the work day/night. If the permanent pavement markings are not installed by the end of the work day/night, then Temporary Plastic Pavement Marking Tape shall be installed as described above and the permanent Epoxy Resin Pavement Markings shall be installed by the end of the work day/night on Friday of that week.

If Temporary Plastic Pavement Marking Tape is installed, the Contractor shall remove and dispose of these markings when the permanent Epoxy Resin Pavement Markings are installed. The cost of furnishing, installing and removing the Temporary Plastic Pavement Marking Tape shall be at the Contractor's expense.

NOTE: Painted pavement markings will not be allowed as a substitution for either the permanent Epoxy Resin Pavement Markings or the Temporary Plastic Pavement Marking Tape on the final course of bituminous concrete pavement.

TRAFFIC CONTROL DURING CONSTRUCTION OPERATIONS (English Version)

The following guidelines shall assist field personnel in determining when and what type of traffic control patterns to use for various situations. These guidelines shall provide for the safe and efficient movement of traffic through work zones and enhance the safety of work forces in the work area.

TRAFFIC CONTROL PATTERNS: Traffic control patterns shall be used when a work operation requires that all or part of any vehicle or work area protrudes onto any part of a travel lane or shoulder. For each situation, the installation of traffic control devices shall be based on the following:

- Speed and volume of traffic
- Duration of operation
- Exposure to hazards

Traffic control patterns shall be uniform, neat and orderly so as to command respect from the motorist.

In the case of a horizontal or vertical sight restriction in advance of the work area, the traffic control pattern shall be extended to provide adequate sight distance for approaching traffic.

If a lane reduction taper is required to shift traffic, the entire length of the taper should be installed on a tangent section of roadway so that the entire taper area can be seen by the motorist.

Any existing signs that are in conflict with the traffic control patterns shall be removed, covered, or turned so that they are not readable by oncoming traffic.

When installing a traffic control pattern, a Buffer Area should be provided and this area shall be free of equipment, workers, materials and parked vehicles.

Typical traffic control plans 20 through 25 may be used for moving operations such as line striping, pot hole patching, mowing, or sweeping when it is necessary for equipment to occupy a travel lane.

Traffic control patterns will not be required when vehicles are on an emergency patrol type activity or when a short duration stop is made and the equipment can be contained within the shoulder. Flashing lights and appropriate trafficperson shall be used when required.

Although each situation must be dealt with individually, conformity with the typical traffic control plans contained herein is required. In a situation not adequately covered by the typical traffic control plans, the Contractor must contact the Engineer for assistance prior to setting up a traffic control pattern.

PLACEMENT OF SIGNS: Signs must be placed in such a position to allow motorists the opportunity to reduce their speed prior to the work area. Signs shall be installed on the same side

of the roadway as the work area. On multi-lane divided highways, advance warning signs may be installed on both sides of the highway. On directional roadways (on-ramps, off-ramps, one-way roads), where the sight distance to signs is restricted, these signs should be installed on both sides of the roadway.

Allowable Adjustment of Signs and Devices
Shown on the Traffic Control Plans

The traffic control plans contained herein show the location and spacing of signs and devices under ideal conditions. Signs and devices should be installed as shown on these plans whenever possible.

The proper application of the traffic control plans and installation of traffic control devices depends on actual field conditions.

Adjustments to the traffic control plans shall be made only at the direction of the Engineer to improve the visibility of the signs and devices and to better control traffic operations. Adjustments to the traffic control plans shall be based on safety of work forces and motorists, abutting property requirements, driveways, side roads, and the vertical and horizontal curvature of the roadway.

The Engineer may require that the traffic control pattern be located significantly in advance of the work area to provide better sight line to the signing and safer traffic operations through the work zone.

Table I indicates the minimum taper length required for a lane closure based on the posted speed limit of the roadway. These taper lengths shall only be used when the recommended taper lengths shown on the traffic control plans cannot be achieved.

TABLE I – MINIMUM TAPER LENGTHS

POSTED SPEED LIMIT MILES PER HOUR	MINIMUM TAPER LENGTH IN FEET FOR A SINGLE LANE CLOSURE
30 OR LESS	180
35	250
40	320
45	540
50	600
55	660
65	780

SECTION 1. WORK ZONE SAFETY MEETINGS

- 1.a) Prior to the commencement of work, a work zone safety meeting will be conducted with representatives of DOT Construction, Connecticut State Police (Local Barracks), Municipal Police, the Contractor (Project Superintendent) and the Traffic Control Subcontractor (if different than the prime Contractor) to review the traffic operations, lines of responsibility, and operating guidelines which will be used on the project. Other work zone safety meetings during the course of the project should be scheduled as needed.
- 1.b) A Work Zone Safety Meeting Agenda, (see Section 9), shall be developed and used at the meeting to outline the anticipated traffic control issues during the construction of this project. Any issues that can't be resolved at these meetings will be brought to the attention of the District Engineer and the Office of Construction.

SECTION 2. INSTALLING AND REMOVING TRAFFIC CONTROL PATTERNS

- 2.a) Lane Closures shall be installed beginning with the advanced warning signs and proceeding forward toward the work area.
- 2.b) Lane Closures shall be removed in the reverse order, beginning at the work area, or end of the traffic control pattern, and proceeding back toward the advanced warning signs.
- 2.c) Stopping traffic may be allowed:
 - As per the contract for such activities as blasting, steel erection, etc.
 - During paving, milling operations, etc. where, in the middle of the operation, it is necessary to flip the pattern to complete the operation on the other half of the roadway and traffic should not travel across the longitudinal joint or difference in roadway elevation.
 - To move slow moving equipment across live traffic lanes into the work area.
- 2.d) Under certain situations when the safety of the traveling public and/or that of the workers may be compromised due to conditions such as traffic volume, speed, roadside obstructions, or sight line deficiencies, as determined by the Engineer and/or State Police, traffic may be briefly impeded while installing and/or removing the advanced warning signs and the first ten traffic cones/drums only. Appropriate measures shall be taken to safely slow traffic. If required, State Police may use traffic slowing techniques, including the use of Truck Mounted Impact Attenuators (TMAs) as appropriate, for a minimum of one mile in advance of the pattern starting point. Once the advanced warning signs and the first ten traffic cones/drums are installed/removed, the two TMAs and sign crew should continue to install/remove the pattern as described in Section 4c and traffic shall be allowed to resume their normal travel.

- 2.e) The Contractor must adhere to using the proper signs, placing the signs correctly, and ensuring the proper spacing of signs.
- 2.f) Additional devices are required on entrance ramps, exit ramps, and intersecting roads to warn and/or move traffic into the proper travel path prior to merging/exiting with/from the main line traffic. This shall be completed before installing the mainline pattern past the ramp or intersecting roadway.
- 2.g) Prior to installing a pattern, any conflicting existing signs shall be covered with an opaque material. Once the pattern is removed, the existing signs shall be uncovered.
- 2.h) On limited access roadways, workers are prohibited from crossing the travel lanes to install and remove signs or other devices on the opposite side of the roadway. Any signs or devices on the opposite side of the roadway shall be installed and removed separately.

**SECTION 3. USE OF HIGH MOUNTED INTERNALLY ILLUMINATED FLASHING
ARROW**

- 3.a) On limited access roadways, one Flashing Arrow shall be used for each lane that is closed. The Flashing Arrow shall be installed concurrently with the installation of the traffic control pattern and its placement shall be as shown on the traffic control plan. For multiple lane closures, one Flashing Arrow is required for each lane closed. If conditions warrant, additional Flashing Arrows should be employed (i.e.: curves, major ramps, etc.).
- 3.b) On non-limited access roadways, the use of a Flashing Arrow for lane closures is optional. The roadway geometry, sight line distance, and traffic volume should be considered in the decision to use the Flashing Arrow.
- 3.c) The Flashing Arrow shall not be used on two lane, two-way roadways for temporary alternating one-way traffic operations.
- 3.d) The Flashing Arrow board display shall be in the “arrow” mode for lane closure tapers and in the “caution” mode (four corners) for shoulder work, blocking the shoulder, or roadside work near the shoulder. The Flashing Arrow shall be in the “caution” mode when it is positioned in the closed lane.
- 3.e) The Flashing Arrow shall not be used on a multi-lane roadway to laterally shift all lanes of traffic, because unnecessary lane changing may result.
- 3.f) If the required number of Flashing Arrows is not available, the traffic control pattern shall not be installed.

SECTION 4. USE OF TRUCK MOUNTED IMPACT ATTENUATOR VEHICLES (TMAs)

- 4.a) For lane closures on limited access roadways, a minimum of two TMAs shall be used to install and remove traffic control patterns. If two TMAs are not available, the pattern shall not be installed.
- 4.b) On non-limited access roadways, the use of TMAs to install and remove patterns closing a lane(s) is optional. The roadway geometry, sight line distance, and traffic volume should be considered in the decision to utilize the TMAs.
- 4.c) Generally, to establish the advance and transition signing, one TMA shall be placed on the shoulder and the second TMA shall be approximately 1,000 feet ahead blocking the lane. The flashing arrow board mounted on the TMA should be in the “flashing arrow” mode when taking the lane. The sign truck and workers should be immediately ahead of the second TMA. In no case shall the TMA be used as the sign truck or a work truck. Once the transition is in place, both TMAs shall travel in the closed lane until all Changeable Message Signs, signs, Flashing Arrows, and cones/drums are installed. The flashing arrow board mounted on the TMA should be in the “caution” mode when traveling in the closed lane.
- 4.d) A TMA shall be placed prior to the first work area in the pattern. If there are multiple work areas within the same pattern, then additional TMAs may be positioned at each additional work area as needed. The flashing arrow board mounted on the TMA should be in the “caution” mode when in the closed lane.
- 4.e) TMAs shall be positioned a sufficient distance prior to the workers or equipment being protected to allow for appropriate vehicle roll-ahead in the event that the TMA is hit, but not so far that an errant vehicle could travel around the TMA and into the work area. For additional placement and use details, refer to the specification entitled “Type ‘D’ Portable Impact Attenuation System”. Some operations, such as paving and concrete repairs, do not allow for placement of the TMA(s) within the specified distances. In these situations, the TMA(s) should be placed at the beginning of the work area and shall be advanced as the paving or concrete operations proceed.
- 4.f) TMAs should be paid in accordance with how the unit is utilized. When it is used as a TMA and is in the proper location as specified, then it should be paid at the specified hourly rate for “Type ‘D’ Portable Impact Attenuation System”. When the TMA is used as a Flashing Arrow, it should be paid at the daily rate for “High Mounted Internally Illuminated Flashing Arrow”. If a TMA is used to install and remove a pattern and then is used as a Flashing Arrow, the unit should be paid as a “Type ‘D’ Portable Impact Attenuation System” for the hours used to install and remove the pattern, typically 2 hours (1 hour to install and 1 hour to remove), and is also paid for the day as a “High Mounted Internally Illuminated Flashing Arrow”.
- 4.g) If the required number of TMAs is not available, the pattern shall not be installed.

SECTION 5. USE OF STATE POLICE OFFICERS

- 5.a) On limited access highways, the Engineer may determine that State Police Officers will be utilized for regional work zone traffic safety and enforcement operations in addition to project-related work zone assignments. State Police Officers shall be uniformed off-duty sworn Connecticut State Police Officers. Their services will also include the use of official State Police vehicles and associated equipment. State Police Officers will be used on all limited access highways. State Police Officers will not be used on non-limited access highways unless specifically under their jurisdiction or authorized in writing by the Engineer. State Police Officers with official State Police vehicles will be used at such locations and for such periods as the Engineer deems necessary to control traffic operations and promote increased safety to motorists through the construction sites.
- 5.b) On a weekly basis, the Contractor shall submit to the Engineer the state police request form (DPS-0691-C) as an indication of their scheduled operations for the following week. This form shall be submitted no later than Wednesday Morning of the week prior to the scheduled operations. The Engineer shall review this schedule and approve the type and number of Officers required by signing off under the "Completed by DOT's Authorized Representative" line on Department of Public Safety Form DPS-0691-C. Once the Engineer has approved the number of Officers requested the Engineer will fax the order to the Department of Public Safety's Overtime Office.
- 5.c) Prior to the start of operations, a meeting will be held with the Contractor, Trooper in charge and Engineer to review the Trafficperson operations, lines of responsibility, and operating guidelines which will be used for the scheduled work.
- 5.d) At least one Officer should be used per critical sign pattern. Shoulder closures and right lane closures can generally be implemented without the presence of a State Police Officer. Likewise in areas with moderate traffic and wide, unobstructed medians, left lane closures can be implemented without State Police presence. Certain situations may require State Police presence, if one is available, even though the general guidelines above indicate otherwise. Examples of this include: nighttime lane closures; left lane closures with minimal width for setting up advance signs and staging; lane and shoulder closures on turning roadways/ramps or mainline where sight distance is minimal; and closures where extensive turning movements or traffic congestion regularly occur.
- 5.e) Once the pattern is in place, the State Police Officer should be positioned in a non-hazardous location at the beginning of the pattern or at one of the work areas not protected by a TMA. If traffic backs up beyond the beginning of the pattern, then the State Police Officer should be repositioned prior to the backup to give warning to the oncoming motorists. Where State Police Officer and TMA are in close proximity to each other, the TMA should be placed to protect the State Police Officer's vehicle from oncoming traffic.
- 5.f) Other functions of the State Police Officer(s) shall include:
- *Assisting entering/exiting construction vehicles within the work area.

- *Enhancing worker visibility/safety for workers in close proximity to the open travel lane(s).
- Speed control of traffic within the work area.
- Enforcement of speed and other motor vehicle laws within the work area.

Typically, the State Police Officer should be out of the vehicle for the functions marked with an asterisk (*).

- 5.g) State Police Officers assigned to a work site are to only take direction from the Engineer.
- 5.h) There will be no separate payment to the Contractor for State Police Services. The direct cost of such services will be paid by the Department. Indirect costs associated with scheduling and coordinating State Police shall be included under the Item – Maintenance and Protection of Traffic.

SECTION 6. USE OF (REMOTE CONTROLLED) CHANGEABLE MESSAGE SIGNS

- 6.a) For lane closures on limited access roadways, one Changeable Message Sign shall be used in advance of the traffic control pattern. Prior to installing the pattern, the Changeable Message Sign shall be installed and in operation, displaying the appropriate lane closure information (i.e.: Left Lane Closed - Merge Right). The Changeable Message Sign shall be positioned ½ - 1 mile ahead of the lane closure taper. If the nearest Exit ramp is greater than the specified ½ - 1 mile distance, than an additional Changeable Message Sign shall be positioned a sufficient distance ahead of the Exit ramp to alert motorists to the work and therefore offer them an opportunity to take the exit.
- 6.b) On non-limited access roadways, the use of Changeable Message Signs for lane closures is optional. The roadway geometry, sight line distance, and traffic volume should be considered in the decision to use the Changeable Message Sign.
- 6.c) The advance Changeable Message Sign is typically placed off the right shoulder, 5 feet from the edge of pavement. In areas where the Changeable Message Sign cannot be placed beyond the edge of pavement, it may be placed on the paved shoulder with a minimum of five (5) traffic drums placed in a taper in front of it to delineate its position. The advance Changeable Message Sign shall be adequately protected if it is used for a continuous duration of 36 hours or more.
- 6.d) When the Changeable Message Signs are no longer required, they should be removed from the clear zone and have the display screen cleared and turned 90° away from the roadway.
- 6.e) The Changeable Message Sign generally should not be used for generic messages (ex: Road Work Ahead, Bump Ahead, Gravel Road, etc.).

- 6.f) The Changeable Message Sign should be used for specific situations that need to command the motorist's attention which cannot be conveyed with standard construction signs (Examples include: Exit 34 Closed Sat/Sun - Use Exit 35, All Lanes Closed - Use Shoulder, Workers on Road - Slow Down).
- 6.g) Messages that need to be displayed for long periods of time, such as during stage construction, should be displayed with construction signs. For special signs, please coordinate with the Office of Construction and the Division of Traffic Engineering for the proper layout/dimensions required.
- 6.h) Section 11 contains the messages that are allowed on the Changeable Message Sign. For any other message(s), approval must be received from the Office of Construction prior to their use. No more than two (2) displays shall be used within any message cycle.
- 6.i) If the required number of Changeable Message Signs is not available, the pattern shall not be installed.

SECTION 7. USE OF (REMOTE CONTROL) CHANGEABLE MESSAGE SIGNS WITH RADAR

- 7.a) (Remote Control) Changeable Message Signs with Radar shall be used when specified, or as directed by the Engineer.
- 7.b) The typical placement of a (Remote Control) Changeable Message Sign with Radar is in the work zone portion of the traffic control pattern.
- 7.c) The typical usage of the (Remote Control) Changeable Message Sign with Radar is to display a message when a preset speed is exceeded. The sign will blank when no vehicles are present.
- 7.d) The preset speed for activating the message should be set 5-10 MPH above the posted, or desired, speed.
- 7.e) Section 12 contains the messages that are allowed on the (Remote Controlled) Changeable Message Sign with Radar. For any other message(s), approval must be received from the Office of Construction prior to their use. No more than two (2) displays shall be used within any message cycle.

SECTION 8. USE OF TRAFFIC DRUMS AND TRAFFIC CONES

- 8.a) Traffic drums shall be used for taper channelization on limited-access roadways, ramps, and turning roadways and to delineate raised catch basins and other hazards.
- 8.b) Traffic drums shall be used in place of traffic cones in traffic control patterns that are in effect for more than a 72-hour duration.

- 8.c) Traffic Cones less than 42 inches in height shall not be used on limited-access roadways or on non-limited access roadways with a posted speed limit of 45 mph and above.
- 8.d) Typical spacing of traffic drums and/or cones shown on the Traffic Control Plans in the Contract are maximum spacings and may be reduced to meet actual field conditions as required.

SECTION 9. GENERAL

- 9.a) If the required minimum number of signs and equipment (i.e. one High Mounted Internally Illuminated Flashing Arrow for each lane closed, two TMAs, Changeable Message Sign, etc.) are not available, the traffic control pattern shall not be installed.
- 9.b) The Contractor shall have back-up equipment (TMAs, High Mounted Internally Illuminated Flashing Arrow, Changeable Message Sign, construction signs, cones/drums, etc.) available at all times in case of mechanical failures, etc. The only exception to this is in the case of sudden equipment breakdowns in which the pattern may be installed but the Contractor must provide replacement equipment within 24 hours.
- 9.c) Failure of the Contractor to have the required minimum number of signs and equipment, which results in the not being installed, shall not be a reason for a time extension.
- 9.d) In cases of legitimate differences of opinion between the Contractor and the Inspection staff, the Inspection staff shall err on the side of safety. The matter shall be brought to the District Office for resolution immediately or, in the case of work after regular business hours, on the next business day.

SECTION 10. WORK ZONE SAFETY MEETING AGENDA

- 1) Review Project scope of work and time.
- 2) Review Section 1.08, Prosecution and Progress of the Special Provisions.
- 3) Review Section 9.70, Trafficperson of the Specifications.
- 4) Review Section 9.71, Maintenance and Protection of Traffic of the Special Provisions, including "Work Zone Safety Procedures".
- 5) Review Contractor's schedule and method of operations.
- 6) Review areas of special concern: ramps, turning roadways, medians, lane drops, etc.
- 7) Open discussion of work zone questions and issues.
- 8) Discussion of review and approval process for changes in contract requirements as they relate to work zone areas.

SECTION 11. WORK ZONE SAFETY PROCEDURES - ALLOWABLE MESSAGES FOR CHANGEABLE MESSAGE SIGNS

<u>Message No.</u>	<u>Frame 1</u>	<u>Frame 2</u>	<u>Message No.</u>	<u>Frame 1</u>	<u>Frame 2</u>
1	LEFT LANE CLOSED	MERGE RIGHT	9	LANES CLOSED AHEAD	REDUCE SPEED
2	2 LEFT LANES CLOSED	MERGE RIGHT	10	LANES CLOSED AHEAD	USE CAUTION
3	LEFT LANE CLOSED	REDUCE SPEED	11	WORKERS ON ROAD	REDUCE SPEED
4	2 LEFT LANES CLOSED	REDUCE SPEED	12	WORKERS ON ROAD	SLOW DOWN
5	RIGHT LANE CLOSED	MERGE LEFT	13	EXIT XX CLOSED	USE EXIT YY
6	2 RIGHT LANES CLOSED	MERGE LEFT	14	EXIT XX CLOSED USE YY	FOLLOW DETOUR
7	RIGHT LANE CLOSED	REDUCE SPEED	15	2 LANES SHIFT AHEAD	USE CAUTION
8	2 RIGHT LANES CLOSED	REDUCE SPEED	16	3 LANES SHIFT AHEAD	USE CAUTION

SECTION 12. WORK ZONE SAFETY PROCEDURES - ALLOWABLE MESSAGES FOR CHANGEABLE MESSAGE SIGN WITH RADAR

<u>Message No.</u>	<u>Frame 1</u>	<u>Frame 2</u>	<u>Message No.</u>	<u>Frame 1</u>	<u>Frame 2</u>
1	TOO FAST	SLOW DOWN	4		
2	TOO FAST SLOW DOWN		5		
3	YOU'RE SPEEDING	FINES DOUBLE	6		

SERIES 16 SIGNS

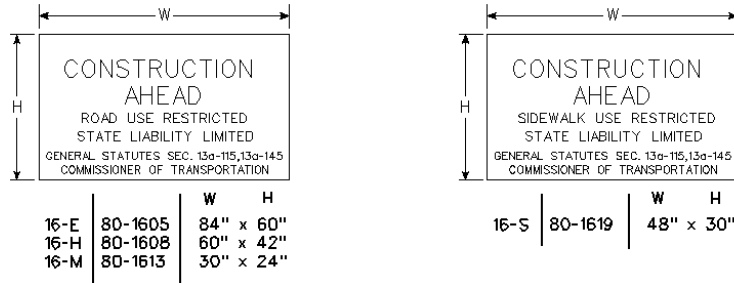

THE 16-S SIGN SHALL BE USED ON ALL PROJECTS THAT REQUIRE SIDEWALK RECONSTRUCTION OR RESTRICT PEDESTRIAN TRAVEL ON AN EXISTING SIDEWALK.

SERIES 16 SIGNS SHALL BE INSTALLED IN ADVANCE OF THE TRAFFIC CONTROL PATTERNS TO ALLOW MOTORISTS THE OPPORTUNITY TO AVOID A WORK ZONE. SERIES 16 SIGNS SHALL BE INSTALLED ON ANY MAJOR INTERSECTING ROADWAYS THAT APPROACH THE WORK ZONE. ON LIMITED- ACCESS HIGHWAYS, THESE SIGNS SHALL BE LOCATED IN ADVANCE OF THE NEAREST UPSTREAM EXIT RAMP AND ON ANY ENTRANCE RAMP PRIOR TO OR WITHIN THE WORK ZONE LIMITS.

THE LOCATION OF SERIES 16 SIGNS CAN BE FOUND ELSEWHERE IN THE PLANS OR INSTALLED AS DIRECTED BY THE ENGINEER.

SIGNS 16-E AND 16-H SHALL BE POST MOUNTED.

SIGN 16-E SHALL BE USED ON ALL EXPRESSWAYS.

SIGN 16-H SHALL BE USED ON ALL RAMPS, OTHER STATE ROADWAYS, AND MAJOR TOWN/CITY ROADWAYS.

SIGN 16-M SHALL BE USED ON OTHER TOWN ROADWAYS.

REGULATORY SIGN "ROAD WORK AHEAD, FINES DOUBLED"

THE REGULATORY SIGN "ROAD WORK AHEAD, FINES DOUBLED" SHALL BE INSTALLED FOR ALL WORK ZONES THAT OCCUR ON ANY STATE HIGHWAY IN CONNECTICUT WHEN THERE ARE WORKERS ON THE HIGHWAY OR WHEN THERE IS OTHER THAN EXISTING TRAFFIC OPERATIONS.

THE "ROAD WORK AHEAD, FINES DOUBLED" REGULATORY SIGNS SHALL NOT BE INSTALLED ON TOWN ROADS.

THE "ROAD WORK AHEAD FINES DOUBLED" REGULATORY SIGN SHALL BE PLACED AFTER THE SERIES 16 SIGN AND IN ADVANCE OF THE "ROAD WORK AHEAD" SIGN.

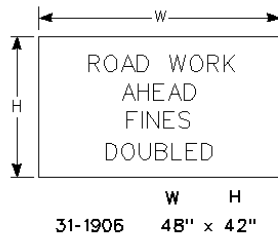

"END ROAD WORK" SIGN

THE LAST SIGN IN THE PATTERN MUST BE THE "END ROAD WORK" SIGN.

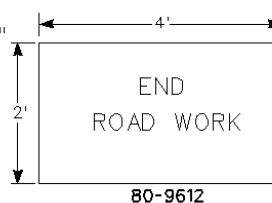

REV'D 1-02



CONNECTICUT
DEPARTMENT OF TRANSPORTATION
BUREAU OF ENGINEERING &
HIGHWAY OPERATIONS
DIVISION OF TRAFFIC ENGINEERING

CONSTRUCTION
TRAFFIC CONTROL PLAN
REQUIRED SIGNS

APPROVED J. Carey DATE 1-02
PRINCIPAL ENGINEER

NOTES FOR TRAFFIC CONTROL PLANS

1. IF A TRAFFIC STOPPAGE OCCURS IN ADVANCE OF SIGN (A), THEN AN ADDITIONAL SIGN (A) SHALL BE INSTALLED IN ADVANCE OF THE STOPPAGE.
2. SIGNS (AA), (A) AND (D) SHOULD BE OMITTED WHEN THESE SIGNS HAVE ALREADY BEEN INSTALLED TO DESIGNATE A LARGER WORK ZONE THAN THE WORK ZONE THAT IS ENCOMPASSED ON THIS PLAN.
3. SEE TABLE #1 FOR ADJUSTMENT OF TAPERS IF NECESSARY.
4. A CHANGEABLE MESSAGE SIGN MAY BE UTILIZED ONE HALF TO ONE MILE IN ADVANCE OF THE LANE CLOSURE TAPER.
5. IF THIS PLAN REMAINS IN CONTINUOUS OPERATION FOR MORE THAN 72 HOURS, THEN TRAFFIC DRUMS SHALL BE USED IN PLACE OF TRAFFIC CONES.
6. ANY LEGAL SPEED LIMIT SIGNS WITHIN THE LIMITS OF A ROADWAY / LANE CLOSURE AREA WILL BE COVERED WITH AN OPAQUE MATERIAL WHILE THE CLOSURE IS IN EFFECT AND UNCOVERED WHEN THE ROADWAY / LANE CLOSURE IS REOPENED TO ALL LANES OF TRAFFIC.
7. IF THIS PLAN REMAINS IN CONTINUOUS OPERATION FOR MORE THAN 36 HOURS, THEN THE EXISTING CONFLICTING PAVEMENT MARKINGS SHALL BE ERADICATED OR COVERED AND TEMPORARY PAVEMENT MARKINGS THAT DEPICT THE PROPER TRAVEL PATHS SHALL BE INSTALLED.
8. DISTANCES BETWEEN SIGNS IN THE ADVANCE WARNING AREA MAY BE REDUCED TO 200' ON LOW SPEED URBAN ROADS (SPEED LIMIT < 40 MPH).
9. FOR LANE CLOSURES ONE (1) MILE OR LONGER, A "REDUCE SPEED TO 45 MPH" SIGN SHALL BE PLACED AT THE ONE MILE POINT AND AT EACH MILE THEREAFTER.
10. IF THIS PLAN IS TO REMAIN IN OPERATION DURING THE HOURS OF DARKNESS, INSTALL BARRICADE WARNING LIGHTS - HIGH INTENSITY ON ALL POST-MOUNTED DIAMOND SIGNS IN THE ADVANCE WARNING AREA.
11. A CHANGEABLE MESSAGE SIGN SHALL BE INSTALLED ONE HALF TO ONE MILE IN ADVANCE OF THE LANE CLOSURE TAPER.



REV'D 1-02

CONNECTICUT
DEPARTMENT OF TRANSPORTATION
BUREAU OF ENGINEERING &
HIGHWAY OPERATIONS
DIVISION OF TRAFFIC ENGINEERING

CONSTRUCTION
TRAFFIC CONTROL PLAN
NOTES

NOTES.DGN

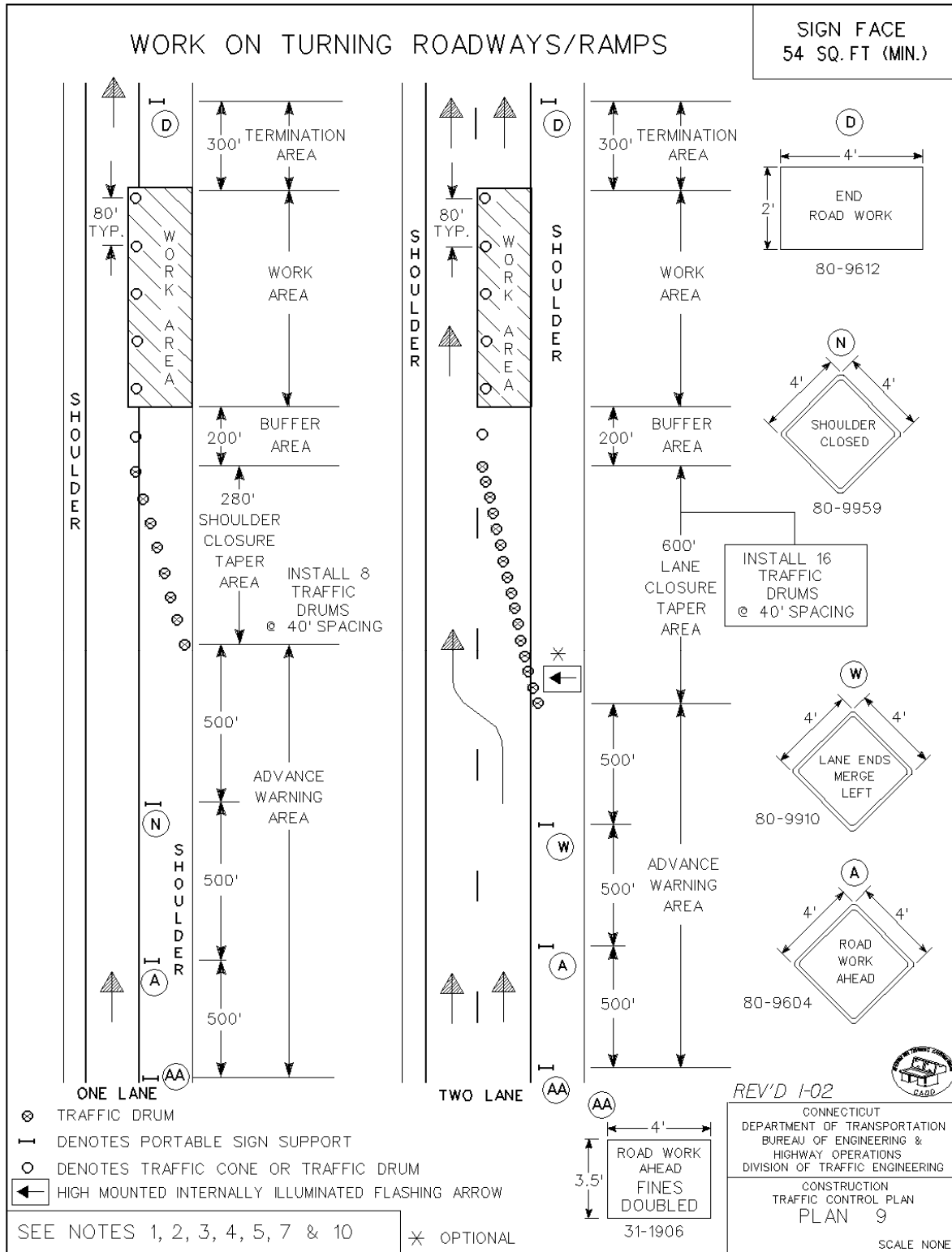

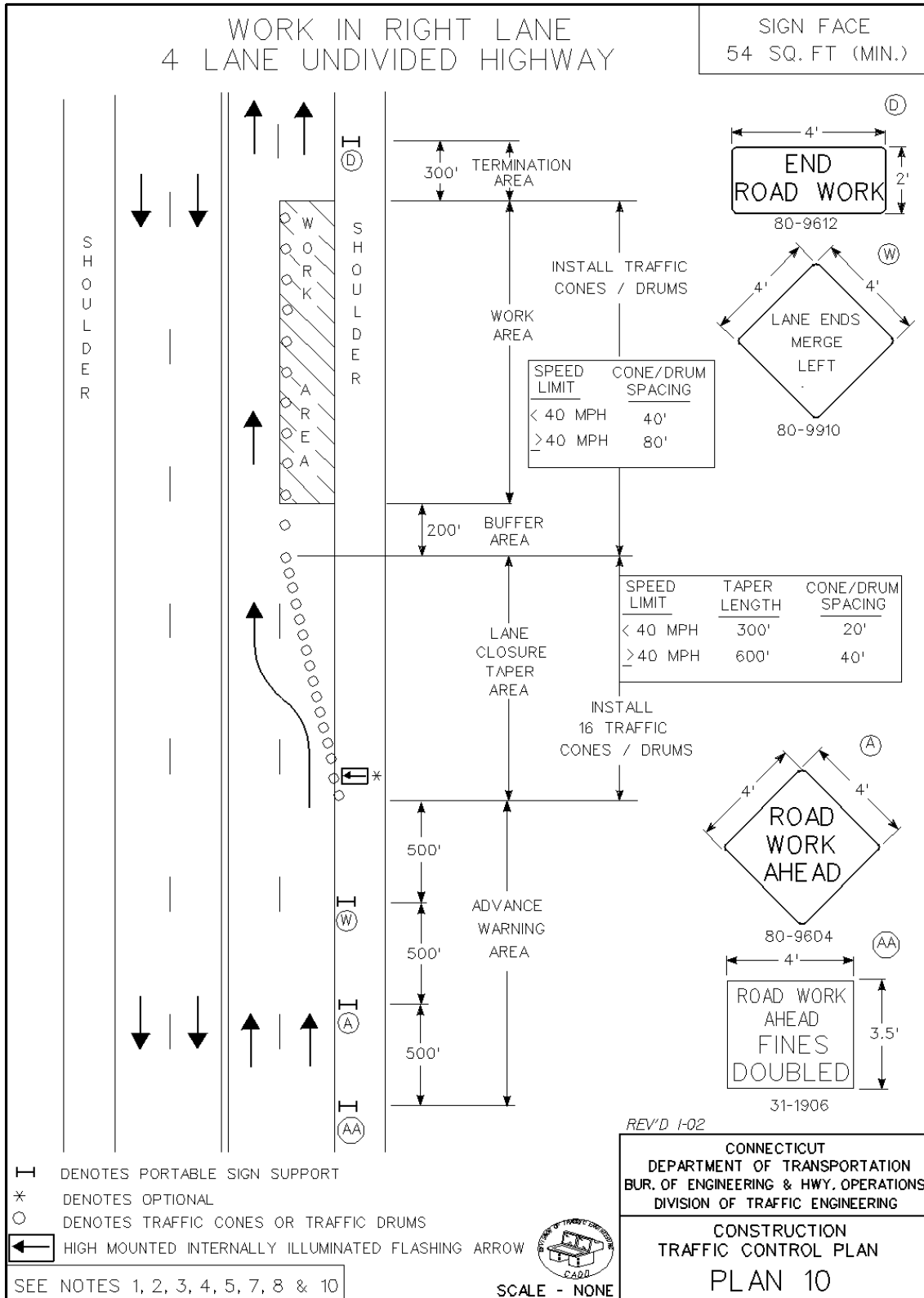

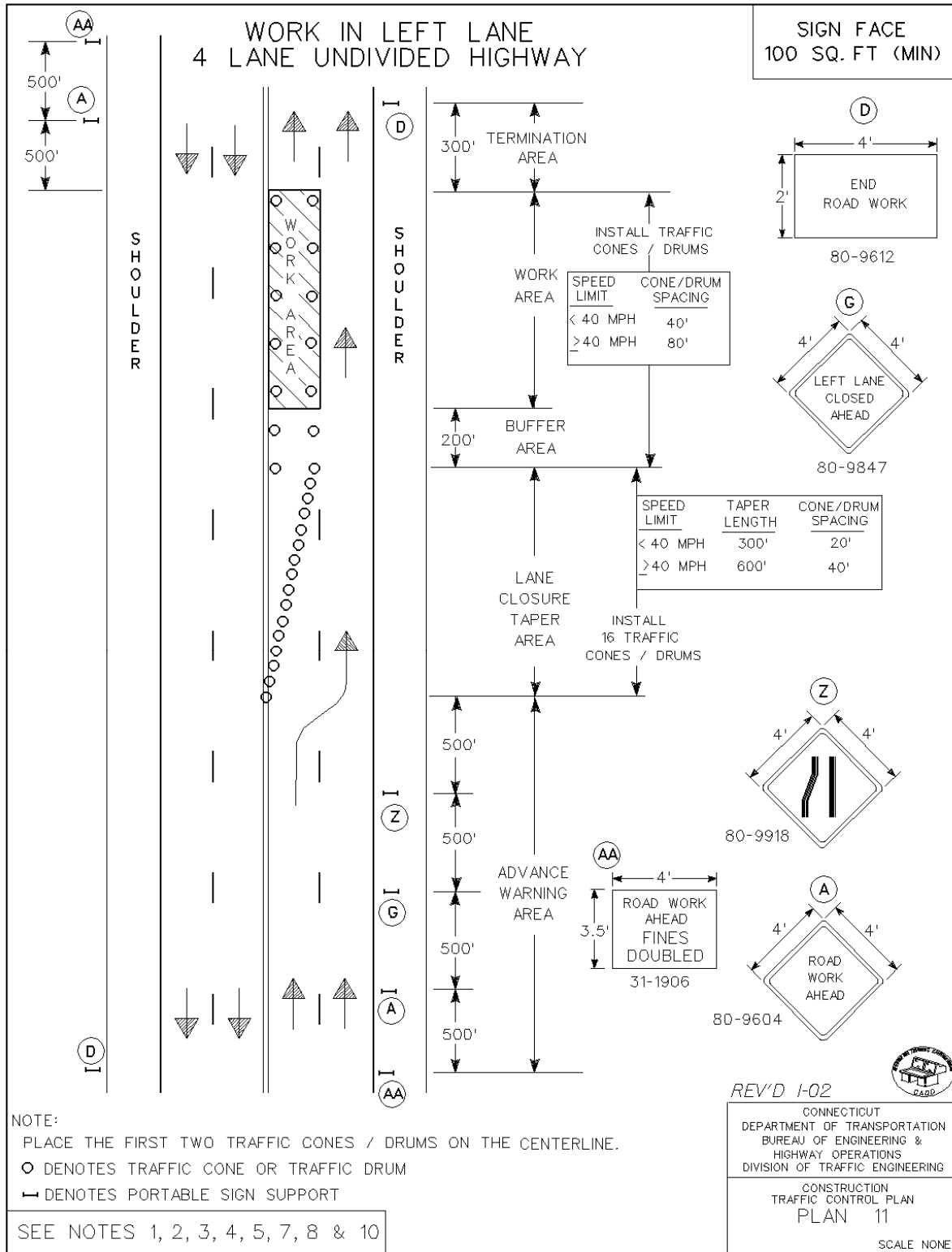

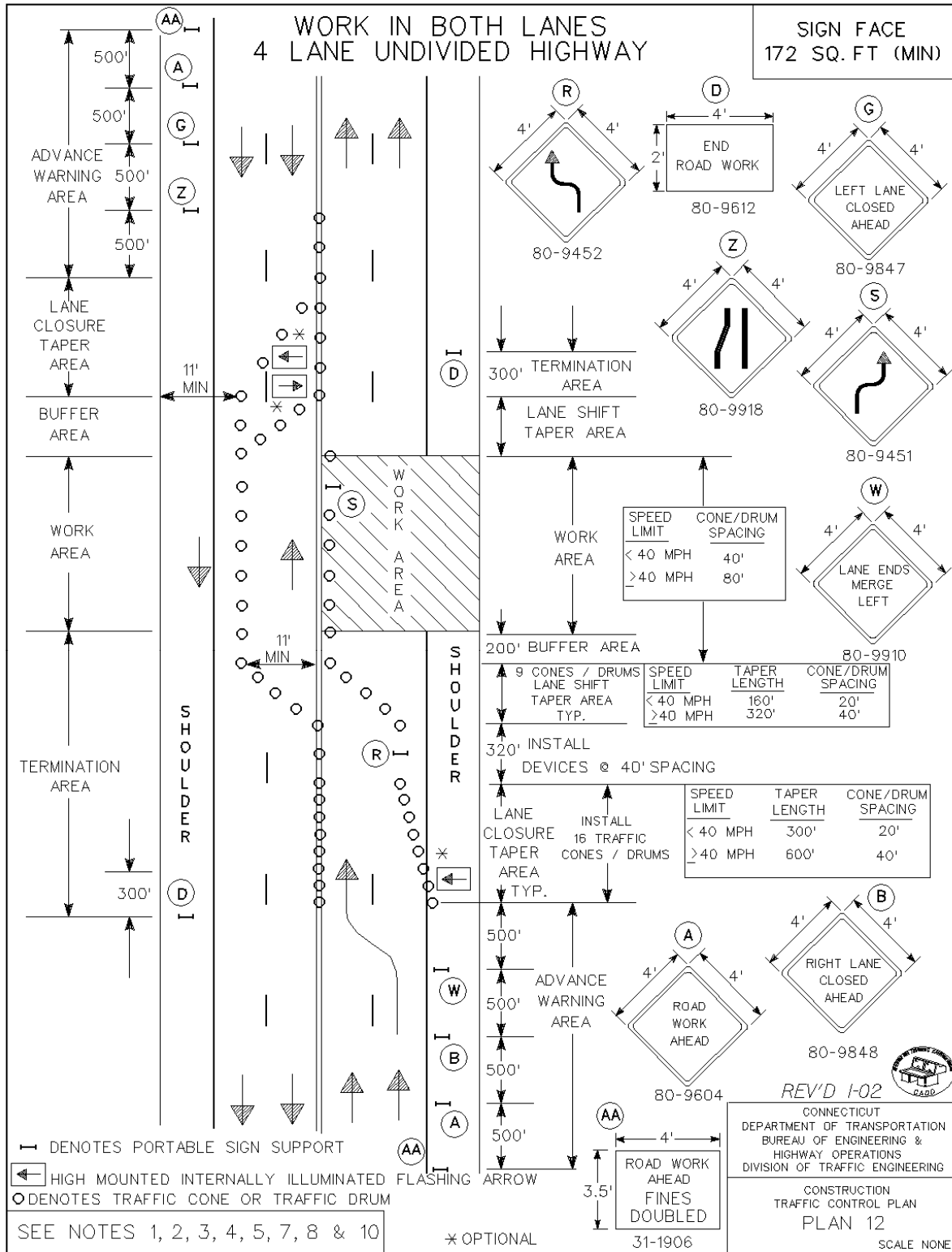

APPROVED J. Carey DATE I-02
PRINCIPAL ENGINEER

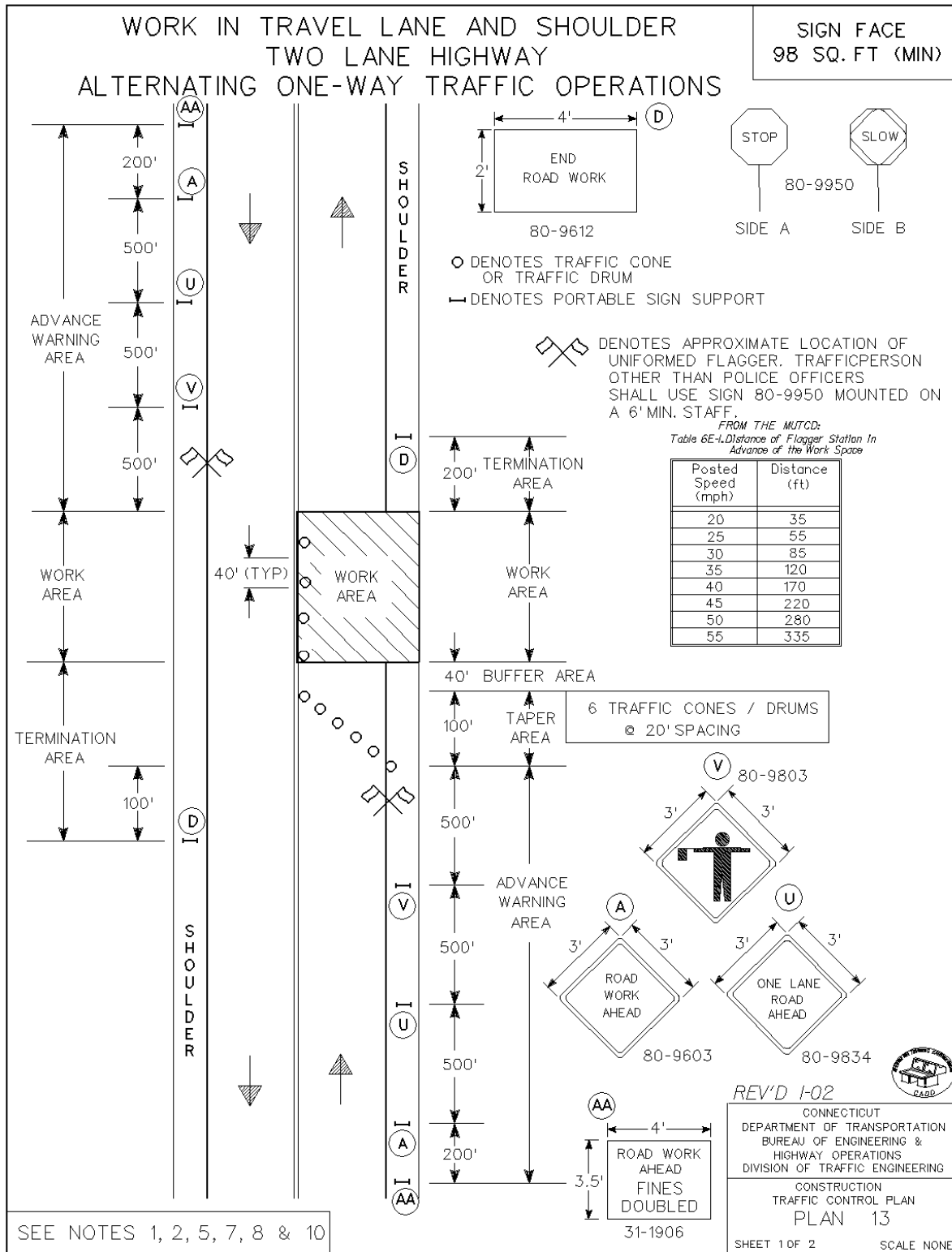

APPROVED J. Carey DATE 1-02
PRINCIPAL ENGINEER

WORK IN TRAVEL LANE AND SHOULDER TWO LANE HIGHWAY ALTERNATING ONE-WAY TRAFFIC OPERATIONS

HAND SIGNAL METHODS TO BE USED BY UNIFORMED FLAGGERS

THE FOLLOWING METHODS FROM SECTION 6E.04 FLAGGER PROCEDURES IN THE "MANUAL ON UNIFORM TRAFFIC CONTROL DEVICES" SHALL BE USED BY UNIFORMED FLAGGERS WHEN DIRECTING TRAFFIC THROUGH A WORK AREA. THE STOP/SLOW SIGN PADDLE (SIGN NO. 80-9950) SHOWN ON THE TYPICAL DETAIL SHEET ENTITLED "SIGNS FOR CONSTRUCTION AND PERMIT OPERATIONS" SHALL BE USED.

A. TO STOP TRAFFIC

TO STOP ROAD USERS, THE FLAGGER SHALL FACE ROAD USERS AND AIM THE STOP PADDLE FACE TOWARD ROAD USERS IN A STATIONARY POSITION WITH THE ARM EXTENDED HORIZONTALLY AWAY FROM THE BODY. THE FREE ARM SHALL BE HELD WITH THE PALM OF THE HAND ABOVE SHOULDER LEVEL TOWARD APPROACHING TRAFFIC.

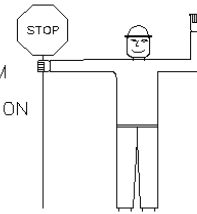

B. TO DIRECT TRAFFIC TO PROCEED

TO DIRECT STOPPED ROAD USERS TO PROCEED, THE FLAGGER SHALL FACE ROAD USERS WITH THE SLOW PADDLE FACE AIMED TOWARD ROAD USERS IN A STATIONARY POSITION WITH THE ARM EXTENDED HORIZONTALLY AWAY FROM THE BODY. THE FLAGGER SHALL MOTION WITH THE FREE HAND FOR ROAD USERS TO PROCEED.

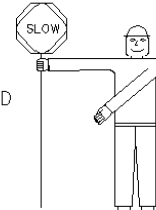

C. TO ALERT OR SLOW TRAFFIC

TO ALERT OR SLOW TRAFFIC, THE FLAGGER SHALL FACE ROAD USERS WITH THE SLOW PADDLE FACE AIMED TOWARD ROAD USERS IN A STATIONARY POSITION WITH THE ARM EXTENDED HORIZONTALLY AWAY FROM THE BODY. TO FURTHER ALERT OR SLOW TRAFFIC, THE FLAGGER HOLDING THE SLOW PADDLE FACE TOWARD ROAD USERS MAY MOTION UP AND DOWN WITH THE FREE HAND, PALM DOWN.

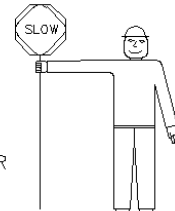

SEE NOTES 1, 2, 5, 7, 8 & 10

REV'D 1-02



CONNECTICUT
DEPARTMENT OF TRANSPORTATION
BUREAU OF ENGINEERING &
HIGHWAY OPERATIONS
DIVISION OF TRAFFIC ENGINEERING

CONSTRUCTION
TRAFFIC CONTROL PLAN
PLAN 13
SHEET 2 OF 2 SCALE NONE

APPROVED J. Carey DATE 1-02
PRINCIPAL ENGINEER

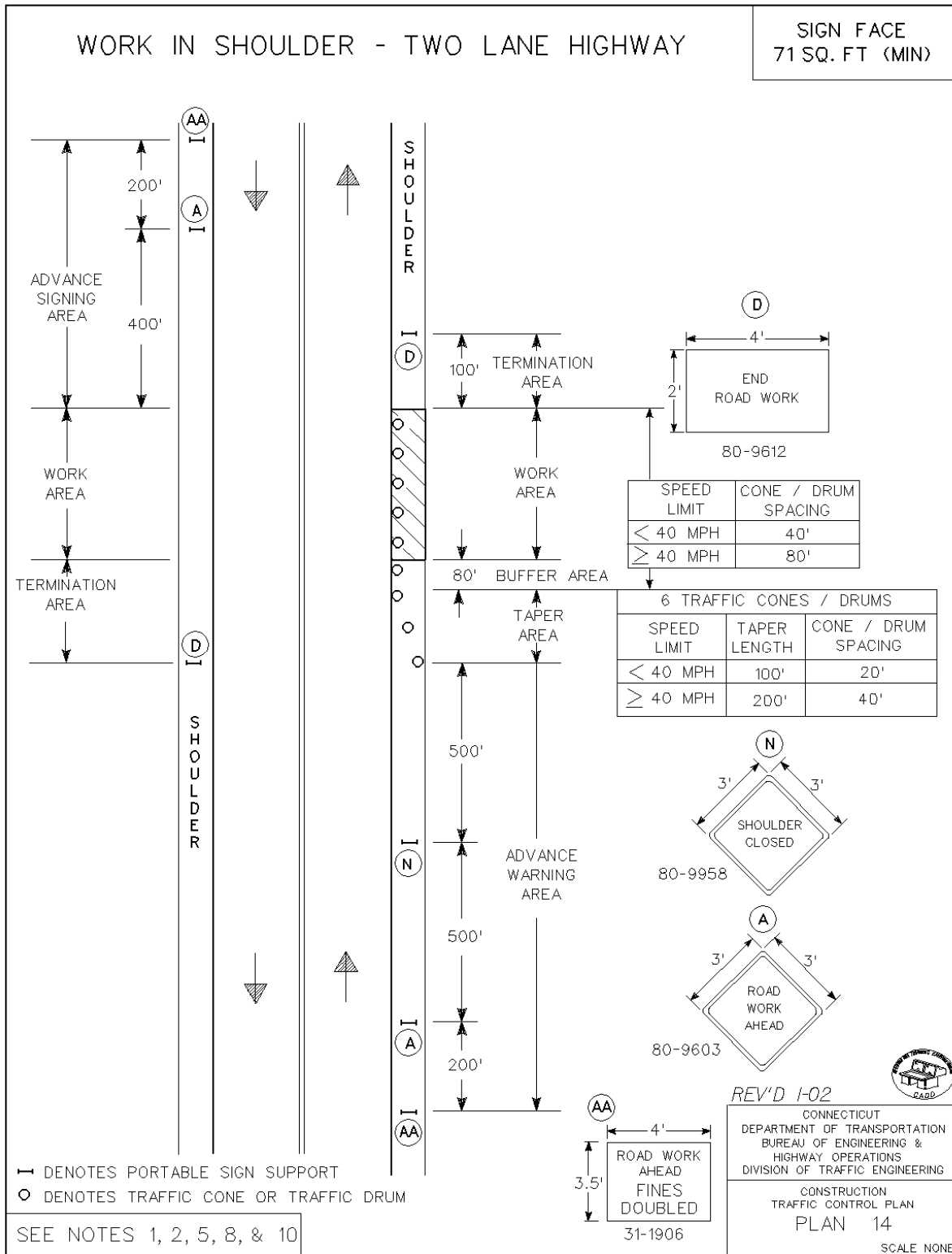

APPROVED J. Carey DATE I-02
 PRINCIPAL ENGINEER

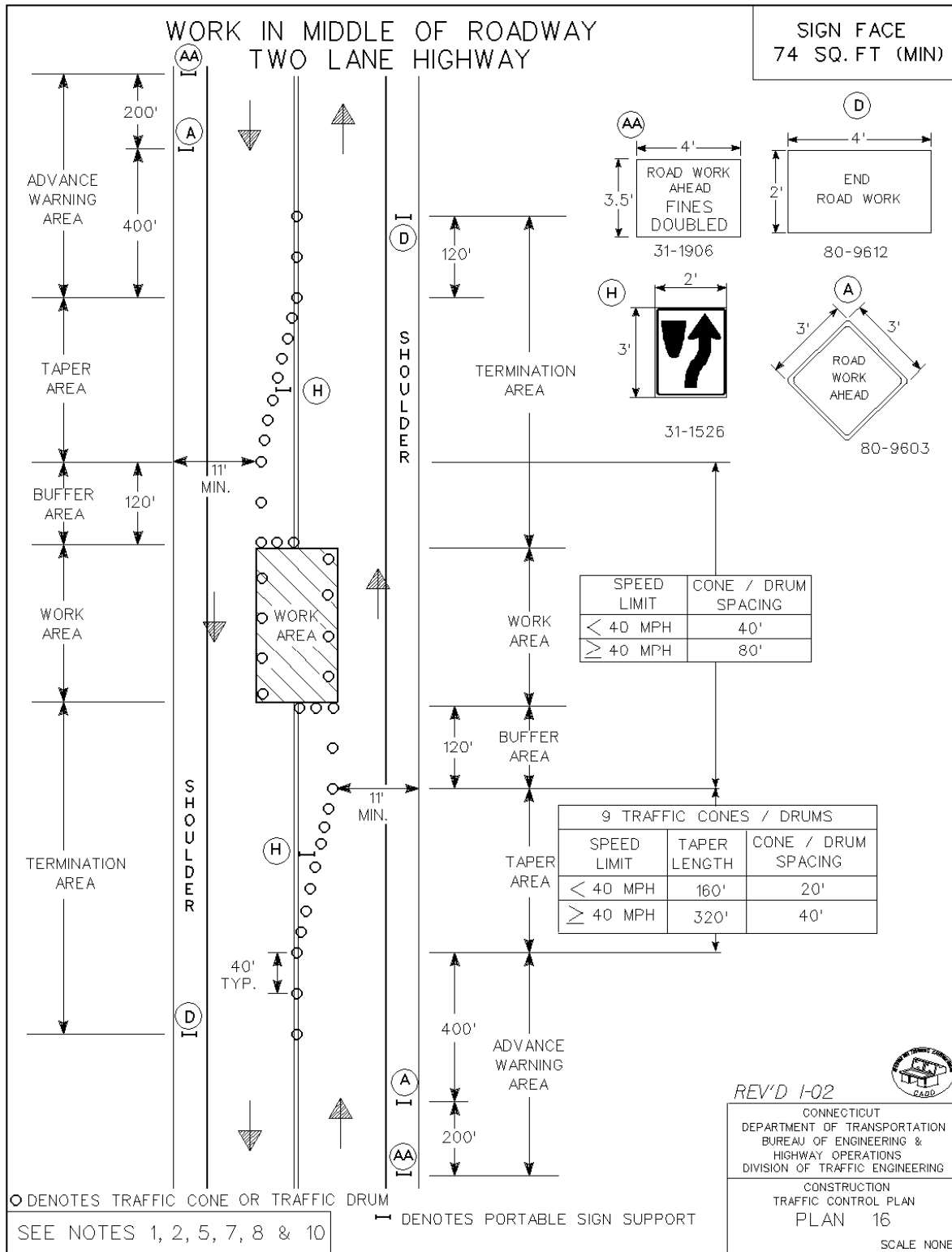

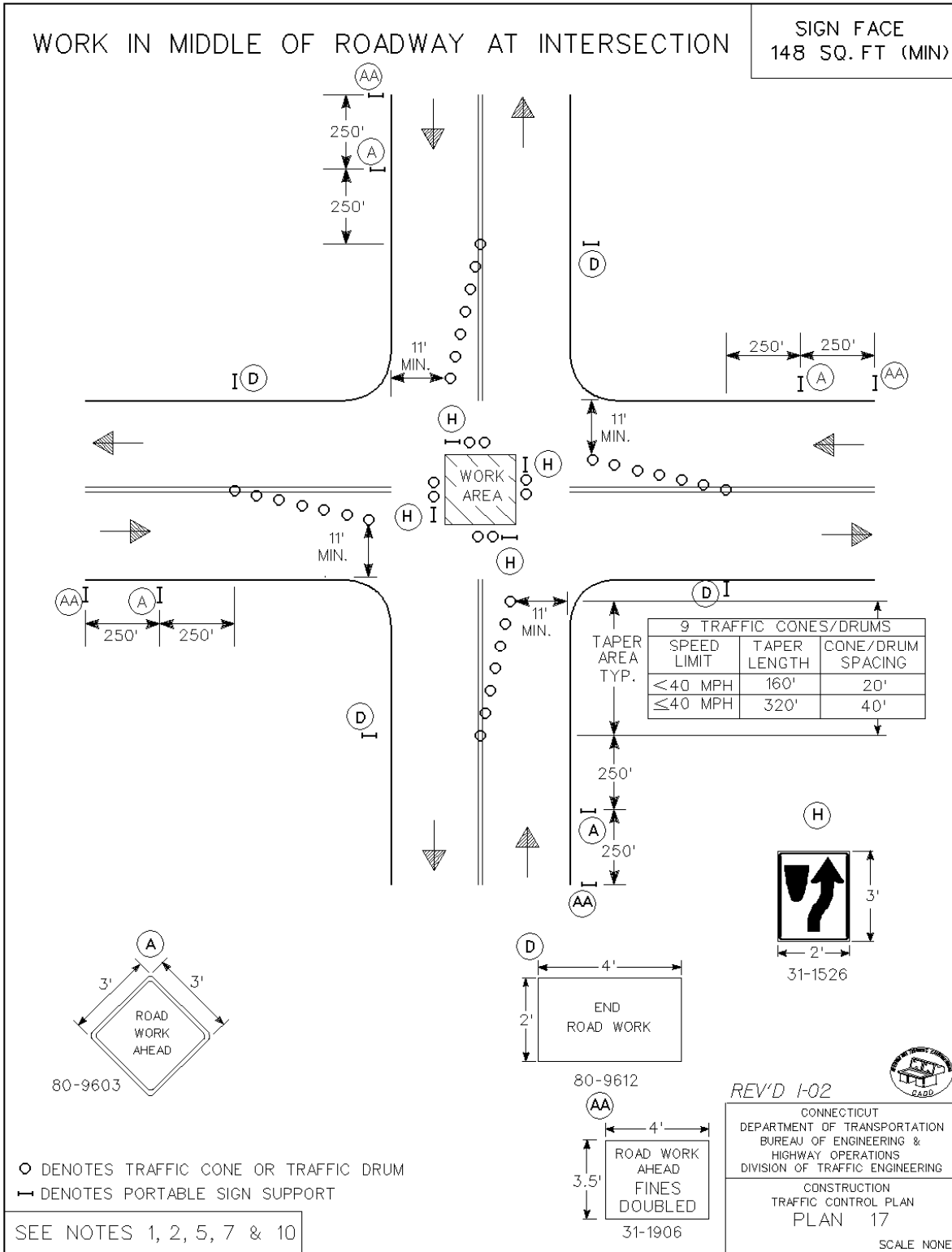

APPROVED J. Carey DATE 1-02
 PRINCIPAL ENGINEER

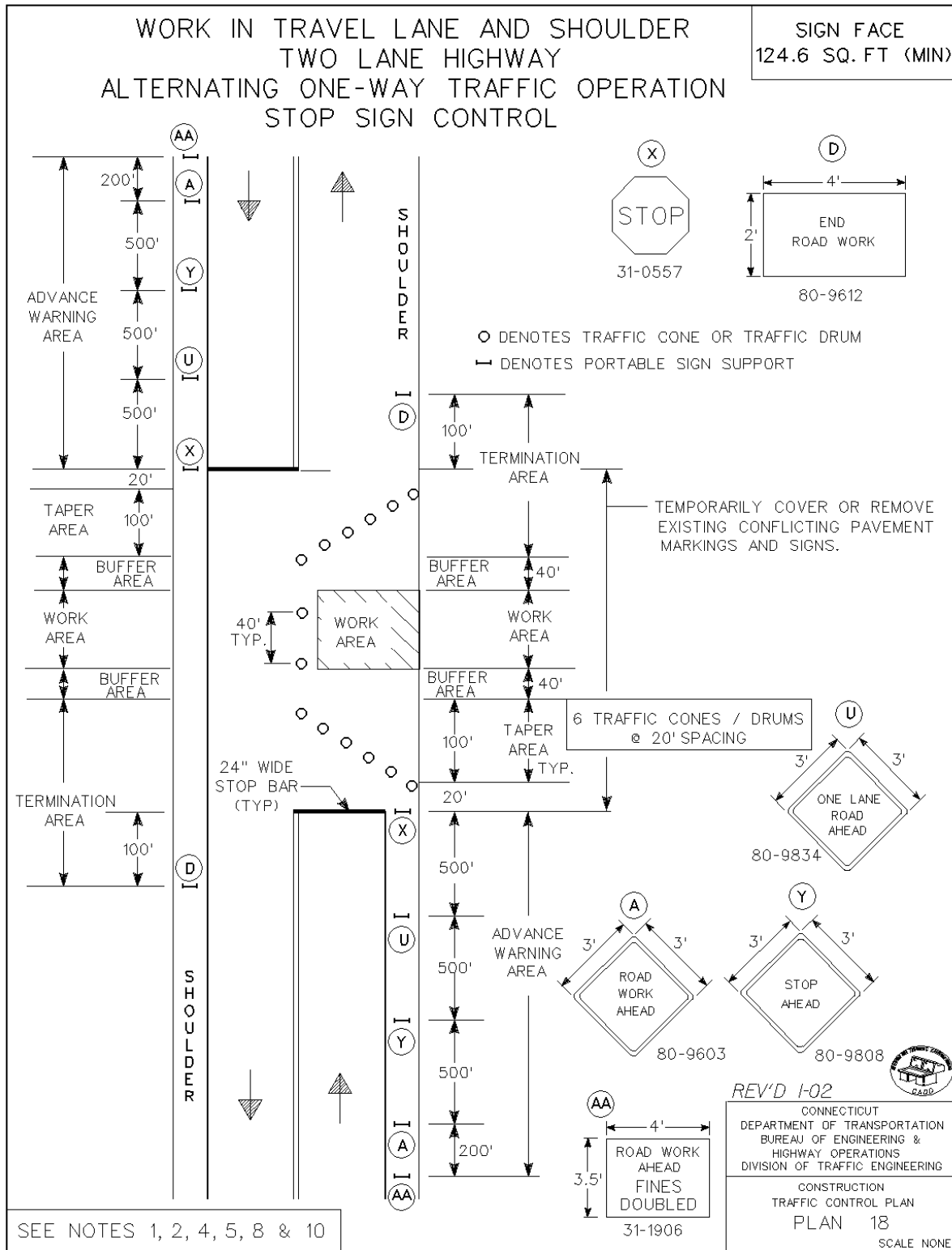

Article 9.71.05 – Basis of Payment is supplemented by the following:

The contract lump sum price for “Maintenance and Protection of Traffic” shall also include furnishing, installing, and removing the material for the temporary traversable slope in those areas where a longitudinal dropdown exists.

If there is no method for payment for the temporary transition in those areas where a transverse dropdown exists, then the contract lump sum price for the “Maintenance and Protection of Traffic” shall also include furnishing, installing, and removing the material for the temporary transition.

The contract lump sum price for “Maintenance and Protection of Traffic” shall also include temporarily relocating existing signs and sign supports as many times as deemed necessary and furnishing, installing, and removing temporary sign supports and foundations if necessary during construction of the project.

ITEM #0980001A – CONSTRUCTION STAKING

9.80.01—Description: The work under this item shall consist of construction layout and reference staking necessary for the proper control and satisfactory completion of all work on the project, except property lines, highway lines, or non-access lines.

9.80.02—Materials: All stakes used for control staking shall be of the same quality as used by the Department for this purpose. For slope limits, pavement edges, gutter lines, etc., where so-called "green" or "working" stakes are commonly used, lesser quality stakes will be acceptable, provided the stakes are suitable for the intended purpose.

9.80.03—Construction Methods: The Department will furnish the Contractor such control points, bench marks, and other data as may be necessary for the construction staking and layout by qualified engineering or surveying personnel as noted elsewhere herein.

The Contractor shall be responsible for the placement and preservation of adequate ties to all control points, necessary for the accurate re-establishment of all base lines, center lines, and all critical grades as shown on the plans.

All stakes, references, and batter boards which may be required for construction operations, signing and traffic control shall be furnished, set and properly referenced by the Contractor. The Contractor shall be solely and completely responsible for the accuracy of the line and grade of all features of the work. Any errors or apparent discrepancies found in previous surveys, plans, specifications or special provisions shall be called to the Engineer's attention immediately for correction or interpretation prior to proceeding with the work.

During roadway construction (or site work), the Contractor shall provide and maintain for the periods needed, as determined by the Engineer, reference stakes at 100 foot intervals outside the slope limits. Further, the Contractor shall provide and maintain reference stakes at 50 foot intervals immediately prior to and during the formation of subgrade and the construction of all subsequent pavement layers. These stakes shall be properly marked as to station, offset and shall be referenced to the proposed grade, even if laser or GPS machine controls are used.

The Contractor shall provide and maintain reference stakes at drainage structures, including reference stakes for the determination of the structure alignments as may be needed for the proper construction of the drainage structure. The reference stakes shall be placed immediately prior to and maintained during the installation of the drainage structure. These stakes shall be properly marked as to station, offset and shall be referenced to the proposed grade.

The Contractor shall furnish copies of data used in setting and referencing stakes and other layout markings used by the Contractor after completion of each operation.

The Contractor shall provide safe facilities for convenient access by Department forces to control points, batter boards, and references.

All staking shall be performed by qualified engineering or surveying personnel who are trained, experienced and skilled in construction layout and staking of the type required under the contract. Prior to start of work, the Contractor shall submit for review and comment the qualifications of personnel responsible for construction staking on the project. On all projects with an original contract value greater than \$25 million and bridge rehabilitation and reconstruction projects greater than \$10 million, surveying shall be performed under the direct supervision of a Professional Surveyor licensed in the State of Connecticut. The submission

shall include a description of the experience and training which the proposed staff possesses and a list of state projects the personnel have worked on previously. All field layout and staking required for the project shall be performed under the direct supervision of a person, or persons, of engineering background experienced in the direction of such work and acceptable to the Engineer. If the personnel responsible for construction staking change during the course of the project, then a revised submittal will be required.

The Department may check the control of the work, as established by the Contractor, at any time as the work progresses. The Contractor will be informed of the results of these checks, but the Department by so doing in no way relieves the Contractor of responsibility for the accuracy of the layout work. The Contractor shall correct or replace, at the Contractor's own expense, any deficient layout and construction work which may be the result of the inaccuracies in the Contractor's staking operations or the failure to report such inaccuracies, or the Contractor's failure to report inaccuracies found in work done by the Department or by others. If, as a result of these inaccuracies, the Department is required to make further studies, redesign, or both, all expenses incurred by the Department due to such inaccuracies will be deducted from any monies due the Contractor.

The Contractor shall furnish all necessary personnel, engineering equipment and supplies, materials, transportation, and work incidental to the accurate and satisfactory completion of this work.

For roadways where the existing pavement markings need to be reestablished:

Prior to any resurfacing or obliteration of existing pavement markings, the Contractor and a representative of the Engineer must establish and document pavement marking control points from the existing markings. These control points shall be used to reestablish the positions of the lanes, the beginnings and endings of tapers, channelization lines for on and off ramps, lane use arrows, stop bars, and any lane transitions in the project area. The Contractor shall use these control points to provide appropriate premarking prior to the installation of the final markings.

The Contractor shall provide and maintain reference stakes and/or markings at 100 foot intervals immediately off the edge of pavement to be used to reestablish the existing pavement markings. The Contractor shall also provide and maintain reference stakes and/or markings at any point where there is a change in pavement markings to reestablish the existing pavement markings.

9.80.04—Method of Measurement: Construction staking will be at the Contract lump sum for construction staking.

When no price for "Construction Staking" is asked for on the proposal form, the cost of the work described above shall be included in the general cost of the work and no direct payment for "Construction Staking" will be made.

9.80.05—Basis of Payment: Construction staking will be paid for at the Contract lump sum price for "Construction Staking," which price shall include all materials, tools, equipment, labor and work incidental thereto. A schedule of values for payment shall be submitted to the Department for review and comment prior to payment.

Pay Item	Pay Unit
Construction Staking	l.s.

ITEM #1008908A - CLEAN EXISTING CONDUIT

Description:

Clean existing conduit as required, as shown on the plans or as directed by the Engineer to remove dirt and debris to facilitate the installation of new cable.

Construction Methods:

Where cable is to be installed in existing conduit the conduit may have to be cleared prior to the installation. Cleaning will only be necessary if the new cable cannot be easily installed in the existing conduit. By field inspection, and with the concurrence of the Engineer, determine the sections of conduit that require cleaning.

Remove all existing cable from conduit. Install temporary cable elsewhere, as necessary, to maintain normal signalization complete with vehicle & pedestrian detection, EVPS, and coordination. Clean the conduit by one of the following methods:

- 1) Rodding.
- 2) A high pressure jet spray, or air pressure.
- 3) By pulling a mandrel or ball through the conduit.

Submit in writing the anticipated method of cleaning the conduit to the Engineer for approval prior to cleaning any conduit.

If the conduit is found damaged to any extent that the cleaning process will not clear the obstruction, it will be the judgment of the Engineer whether to replace the entire conduit run or excavate and replace only the damaged section.

If the existing conduit is found to be missing hardware such as bonding bushings and bond wire, the missing material shall be provided and installed under this item prior to installation of the cable.

Method of Measurement:

This work shall be measured from termination point to termination point. This work shall be measured for payment on actual number of linear feet (meters)..

Basis of Payment:

The work under the Item "Clean Existing Conduit" shall be paid for at the contract unit price per linear foot (meters), which price shall include all material, tools, equipment, labor, and work incidental thereto. Work pertaining to temporary operation shall be paid for under Item 1108xxxA - Temporary Signalization (Site X). Replacement of any damaged conduit shall be paid for under the applicable conduit item.

Pay Item	Pay Unit
Clean Existing Conduit	l.f. (m)

ITEM #1010052A – CAST IRON HANDHOLE COVER

ITEM #1010054A – CAST IRON HANDHOLE COVER – TYPE II

Article 10.10.05 - Basis of Payment:

After the words “Cast Iron Handhole Cover, insert the phrase “of the type called for”.

Add to the list of pay items:

Pay Item	Pay Unit
Cast Iron Handhole Cover Type II	EA.
Cast Iron Handhole Cover Type I	EA.

s:\traffic\1406\signal specs\specs\10100xxA-Section 1010 Concrete Handhole.items_7-10doc

ITEM #1017032A - SERVICE (METERED)

Description:

Furnish and install a metered electric service at the location shown on the plans or as directed by the Engineer.

Materials:

- Meter Socket
 - UL listed
 - Manual lever bypass
 - Locking metal cover for the glass enclosure
 - Contact the serving utility company for a list of approved meter sockets
- Conduit Bond Clamp
 - UL listed
 - Rated for direct burial

Locations served by United Illuminating (UI) or Wallingford Electric Division (WED)

Meter socket rated at 100 amps

Locations served by Connecticut Light and Power Co. (CL&P)

Meter socket rated at 200 amps

Enclosure capable of accepting a 3 inch (75 mm) rigid metal conduit (RMC)

Construction Methods:

Comply with the National Electric Code (NEC), the Department of Public Utilities Control (DPUC), and the serving power company requirements. Install a meter socket with associated equipment on the outside of the controller cabinet, as shown on the plans. Mount the enclosure approximately 54 inches (1.37 meters) above the ground. Install an expansion fitting in the RMC between the ground and the enclosure. Attach a direct-buried bond clamp to the service RMC below ground level, adjacent to the foundation. Bond the service conduit to the controller cabinet ground rod. Install a continuous nylon pull rope of at least 200 lbs (90 Kg) breaking strength in the conduit between the meter socket and the service source. Ensure all circuit breakers are off when service is connected by the utility company. The work must be inspected and approved by the Engineer or his designated representative prior to scheduling a service connection. Record the meter number and the date service is connected for billing purposes.

Service Request

- Traffic Signal on State Road: Contact the CT DOT Traffic Electrical office to complete the necessary service request forms.
- Traffic Signal on Town Road: Complete all necessary request forms and forward to the appropriate power company office.
- Incident Management Site: Complete all necessary request forms and forward to the appropriate power company office.

Locations served by United Illuminating

Contact the UI office to have a Job Number assigned. When the work is complete notify the Engineer to inspect and confirm that the work is according to the National Electric Code. Request that the Engineer contact the United Illuminating, Work in Progress office, to report the job number and to schedule a service connection.

Locations served by Wallingford Electric Division

Contact the Electric Division, Engineering Office to arrange for service and/or to schedule work by the Electric Division on utility poles above 10 feet (3 meters). When the work is complete notify the Engineer to inspect and confirm that the work is according to the National Electric Code. Request that the Engineer contact the Electric Division 24 hours prior to the desired connection date.

Locations served by Connecticut Light and Power Co. and all other electric power providers

Contact the power company engineering representative for exact requirements of the service. All riser fees and any other installation charges required of an underground metered service are the responsibility of the Contractor. When the work is complete notify the Engineer to inspect and confirm that the work is according to the National Electric Code. Request that the Engineer contact the power company to schedule the connection.

Method of Measurement:

The installation of the Service (Metered) will be measured for payment by the number of metered electric services of the type specified, completed, with service connected, and accepted in place.

Basis of Payment:

This work will be paid for at the contract unit price each for "Service (Metered)" complete and accepted in place. The price shall include all material above ground such as the meter socket enclosure, surface conduit, expansion fitting, coupling, and load side service conductors. The price shall also include the direct-buried ground clamp, bonding wire, pull rope, all material, equipment, tools, labor and incidentals necessary.

The power company will provide the line-side conductors and the meter.

s:\traffic\1406\signal specs\specs\1017032A-SERVICE (METERED), 3-10.doc

ITEM #1101303A - POLE ANCHOR

Description: Arrange with the utility company for the installation of an anchor and guy on a utility pole. In accordance with the Department of Public Utility Control regulations 16-243, the electric distribution company will provide and install the anchor and guy for a utility pole in which it owns an interest. If the electric distribution company does not own an interest, the pole custodian will provide and install the anchor and guy.

Material: Materials provided by utility company.

Construction Methods: Contact the electric distribution company to schedule the installation of the anchor and guy strand. If the electric distribution company does not own an interest in the pole contact the pole custodian to schedule the anchor & guy installation. Verify the below information when shown on the plans and provide the information to the utility company. If not shown on the plans, provide all of the required information to the utility company.

- Attachment point
- Type of hardware needed
- Span load
- Direction of span

Ensure the anchor is in line with the proposed traffic signal span wire. More than 5 degree deviation will lower the holding strength and is not allowed. Provide any necessary assistance required by the utility company. Ensure the anchor and guy has been installed and properly tensioned prior to attaching the span wire to the utility pole.

Method of Measurement: This work will be measured for payment for each pole anchor at the actual cost to the Contractor, plus Administrative Expenses as stated in Article 1.09.04 – Extra and Cost-Plus Work, Subsection (e) Administrative Expense, of the Standard Specifications, Form 816.

The sum of money shown in the Contract’s Schedule of Prices and in the itemized Proposal Form as “Estimated Cost” for this work is considered the price bid. Payment will be made only for actual work performed by the utility company and paid for by the Contractor. Furnish receipted invoices to the State clearly documenting work performed by the utility company and paid for by the Contractor.

Basis of Payment: Under this item, the Contractor will be reimbursed for the actual cost of the installation of the anchor and guy by the utility company, plus Administrative Expense, which price shall include all necessary meetings, negotiations, span load calculations, and discussions with utility representatives.

Pay Item
Pole Anchor

Pay Unit
Estimated Cost Plus

ITEM #1105001A - 1 WAY, 1 SECTION SPAN WIRE TRAFFIC SIGNAL

ITEM #1105003A - 1 WAY, 3 SECTION SPAN WIRE TRAFFIC SIGNAL

ITEM #1105007A - 2 WAY, 3 SECTION SPAN WIRE TRAFFIC SIGNAL

ITEM #1105011A - 3 WAY, 3 SECTION SPAN WIRE TRAFFIC SIGNAL

ITEM #1105180A - 1 WAY, 1 SECTION BI-COLORED ARROW

ITEM #1105203A - 1 WAY, 3 SECTION POLE MOUNTED TRAFFIC SIGNAL

ITEM #1105303A - 1 WAY, 3 SECTION PEDESTAL MOUNTED TRAFFIC SIGNAL

Article 11.05.03 – Construction Methods:

Add the following paragraph:

When LED signals are used, measure the off-state voltage of all green indications, with the lamp loads attached. An abnormally high reading may indicate a high impedance neutral or a defective load switch. If this condition exists make all necessary corrections prior to leaving the signal in operation. Circular indications that have an identification mark (such as an arrow) on the top of the lens shall be installed with that mark at the 12 o'clock position.

Article M.16.06 - Traffic Signals

Sub Article 3 - Housing:

In the last sentence, after the word “housing” add “and all internal hardware”.

Add the following after the last paragraph.

Each section of the housing shall be provided with a removable visor. The visor shall be the cap type, unless otherwise noted on the plan. The visor shall be a minimum .05 inch (.13 mm) thick. The visor shall be the twist on type and secured to the signal by four equidistant flat tabs screwed to the signal head.

Sub Article 5 - Optical Unit:

Sub Article 6 - Lamp Socket:

Combine Sub Article 6 with Sub Article 5.
Rename Sub Article 5 “Optical Unit, Incandescent”.

Create a new Sub Article 6 as follows:

Sub Article 6 - Optical Unit, Light Emitting Diode:

(a) General:

The materials for Light Emitting Diode (LED), Optical Unit, circular and arrow, shall conform to the **Department of Transportation Functional Specifications for Traffic Control Equipment, dated 2008 - 2010**. The Functional Specifications are advertised biennial for vendors to provide equipment to the State on a low bid basis.

The **Optical Unit** shall be made up of a smooth surfaced outer shell, multiple LED light sources, a filtered power supply and a backcover, assembled into a sealed unit. Red and yellow LED indications shall be **Aluminum Indium Gallium Phosphide (AlInGaP)** type. Green indications shall be **Indium Gallium Nitride (InGaN)** type. **The Optical Unit** shall be warranted for a minimum of five years.

The Optical Unit shall be extended view (non-blanking). It shall have a vertical cone of view which remains visible at department approved distance for a 55 mph approach speed during windy conditions, until obscured by the visor.

The Optical Unit shall be capable of flash operation with no restrictions or degradation of performance.

The Arrow Optical Unit shall be "Omni-Directional" so that it may be oriented in a right, left or straight configuration without degradation of performance.

(b) Electrical Requirement:

All LED Optical Units shall adhere to the Energy Policy Act of 2005.

Operating voltage:

Circular Indications: 80 to 135 Volts AC
Arrow Indications: 89 to 135 Volts AC with cutoff voltage (no visible indication) below 35Volts AC.

Power requirements:

Circular Indications: 12", (300mm) - 11 to 37 Watts
Circular Indications: 8", (200mm) - 8 to 19 Watts
Arrows Indications: 12", (300mm) - 9 to 11 Watts

Power Supply:

Fused and filtered to provide excess current protection and over voltage protection from electrical surges and transient voltages. 2 Amp maximum.

Parallel Circuits:

Circular Indications: 12", (300mm) - Minimum 6 parallel circuits
Circular Indications: 8", (200mm) - Minimum 3 parallel circuits
Arrows Indications: 12", (300mm) - One burned out LED shall not affect more than 5 percent of the total circuit.

(c) Optical Requirement for Circular LED Units

Beam Color:

Red, Yellow & Green, 12", (300mm), 8", (200mm):
- Meet ITE Specification

Beam Intensity:

Red & Green Indications, 12" (300mm) and 8" (200mm):
- Meet ITE Specification

Yellow Indications, 12" (300mm) and 8" (200mm):
- Twice the ITE requirement for Red indications.
- Not degrade by more than 10% per year.

(d) Optical Requirement for 12" Arrow LED Units

Beam Color:

Meet MUTCD Specifications or Department approval.

Beam Intensity:

Meet MUTCD Specifications or Department approval.
Not degrade by more than 10% per year.

Beam Pattern:

Meet MUTCD Specifications or Department approval.

(e) Mechanical Requirements:

Diameter:

The Circular Optical Unit shall fit into standard 12" (300mm) or 8" (200mm) housing.
The Arrow Optical Unit shall fit 12" (300mm) housings only.

Enclosure:

UV (Ultraviolet) stabilized polycarbonate backcover.
Clear lens cover for all Red, Yellow and Green Circular Optical Units.
For Arrow Optical Units the arrow indication segment of the lens shall be clear.
Enclosure sealed and waterproofed to eliminate dirt contamination and be suitable for installation in all weather conditions.

Clearly mark on the housing the following information:

- Manufacturer & model number
- Date of manufacture
- The words "EXTENDED VIEW"

The model number shall end with the number of LEDs used to comprise the unit as the last digits of the model number. Example, if the unit comprised of 198 LEDs and the model is x12y, then the new model number shall read x12y198.

Operating temperature:

-40 degrees Fahrenheit to 165 degrees Fahrenheit.
(-40 degrees Celsius to 74 degrees Celsius.)

Wiring:

All Optical Units shall have color coded 16 AWG wires for identification of heads and shall be terminated with a Bowma-Crimp style spade lug, 6-8 stud/ 16-14 wire size.
All Circular Optical Units shall be supplied with a minimum 40" pigtail and all Arrow Optical Units with a minimum 60" pigtail.

Sub Article 9 - Painting:
Add the following:

All brackets and hardware shall be painted dark green by the manufacturer. The color shall be No. 14056, Federal Standard No. 595.

S:\traffic\1406\signal specs\specs\1105xxxA-x WAY x SECTION--.doc

ITEM #1106001A - 1 WAY PEDESTRIAN SIGNAL POLE MOUNTED

ITEM #1106003A - 1 WAY PEDESTRIAN SIGNAL PEDESTAL MOUNTED

ITEM #1106004A - 2 WAY PEDESTRIAN SIGNAL PEDESTAL MOUNTED

Section 11.06.02 Pedestrian Signal, Materials

Section M.16.07 C. Optical Unit

Delete 2. LED: and replace with the following:

General

- Meet requirements of current MUTCD Section 4E.
- Meet current ITE specifications for Pedestrian Traffic Control Signal Indications - (PTCSI) Part 2: Light Emitting Diode (LED).
- Meet CT DOT, 2008 - 2010 Functional Specifications for Traffic Control Equipment; Section 5D, LED Pedestrian Signal with Countdown Timer.
- Meet EPA Energy Star® requirements for LED Pedestrian Signal Modules.

Operational

- Countdown display only during the flashing Pedestrian Clearance (Ped Clr) Interval. Timer goes blank at end of flashing ped clr even if countdown has not reached zero.

Physical

- Sealed optical module to prevent entrance of moisture and dust.
- Self-contained optical module, including necessary power supplies.
- Designed to securely fit into standard housing without the use of special tools or modifications to the housing.
- Identification information on module: manufacturer's name, model number, serial number, and date code.

Optical

- Multiple LED sources; capable of partial loss of LED's without loss of symbol or countdown message.
- Two complete self contained optical systems. One to display the walking person symbol (walk) and the hand symbol (don't walk). One to display the countdown timer digits.
- Visual Image similar to incandescent display; smooth, non-pixelated.
- Symbol and countdown digit size as shown on the plan.
- Solid hand/person symbol; outline display not allowed.
- Overlaid hand/person symbols and countdown digits arranged side by side.
- Countdown digit display color: Portland Orange in accordance with ITE requirements.
- Countdown digits comprised of two seven segments, each in a figure 8 pattern.
- Photometric Requirements: Luminance, Uniformity, and Distribution in accordance with ITE requirements.

- Color Uniformity in accordance with ITE requirements.
- Blank-Out design; symbols and digits illegible even in direct sunlight when not illuminated.

Electrical

- Operating voltage: 89 VAC to 135 VAC.
- Low Voltage Turn-Off: 35 VAC.
- Turn-On and Turn-Off times in accordance with ITE specifications.
- Combined Hand – Countdown Digits wattage: ≥ 20 Watts.
- Input impedance at 60 Hertz sufficient to satisfy Malfunction Management Unit (MMU) requirements.
- Two separate power supplies. One to power the walking person symbol. One to power the hand symbol and the countdown digits.
- Meet Federal Communication Commission (FCC) regulations concerning electronic noise.
- Filtered and protected against electrical transients and surges.

Warranty

- Five years from date ownership is accepted.

ITEM #1107007A - PEDESTRIAN PUSHBUTTON AND SIGN (PIEZO)

Article M16.08 - Pedestrian Push Button:

Delete the entire section and replace with the following:

A. General

- Size and force compliant with ADA, Section 14.2.5, Crossing Controls.
- Tamper-proof, and Vandal-proof, Weatherproof, Freeze-proof, Impact-resistant design and construction.
- Completely insulated to preclude electrical shock under any weather conditions.
- Wire entrance through the rear.
- Stainless steel mounting hardware.

B. Actuation

1. Mechanical:

- Single momentary contact switch with tactile feedback.
- Rated at 10 amps, 125 volts.
- Normally open, closed when actuated.

2. Piezo:

- Either non-movable or minimal movement ($< 1/16''$ (1.6)) pressure activation.
- Audible confirmation beep to correspond with circuit closure.
- Visual confirmation LED. On for .025 second to correspond with audible on beep and circuit closure. Visual angle: 160 degrees.
- Minimum 100,000,000 actuations.

C. Housing

- Die cast aluminum meeting requirements of ASTM B85.
- Designed to attach 9" x 12" (230 x 300) four-hole advisory sign.
- Flat back to facilitate surface mount.
- Available hardware to either pedestal top-mount or pole side-mount on diameter range of 3½" (89) to 15" (380).

D. Finish

- Method: Either
 1. Painted with 3 coats of infrared oven-baked paint before assembly.
 - Primer: Baked iron oxide which meets or exceeds FS TT-P-636.
 - Second coat: Exterior-baking enamel, light gray, which meets or exceeds FS TT-E-527.
 - Third coat: Exterior-baking enamel, which meets or exceeds FS TT-E-489.
 2. Electrostatic powder coated after chemically cleaned.
- Color: Dark Green, Federal No 14056, Federal standard No. 595.

ITEM #1108115A - FULL ACTUATED CONTROLLER 8 PHASE

Article 11.08.01 - Description: Delete the second paragraph and replace with the following:

This item shall consist of furnishing and installing an actuated controller, which shall be a completely digital solid state unit, for controlling the operation of the traffic signals.

The controller shall be completely furnished with the number of phases called for in the item. The cabinet to house the controller shall be completely wired and all sub-bases shall be complete with load switches and flash relays as specified in the **Functional Specifications For Traffic Control Equipment**. The cabinet shall also have all necessary auxiliary equipment required to provide the sequence and timing indicated on the plans. A time switch shall be installed in each cabinet.

Article M.16.09 - Controllers: Add the following sub-articles:

2. Actuated Controllers: The purpose of this sub-article is to set forth minimum design and operating requirements for the materials and components for a digitally timed actuated controller.

UNIFORM CODE FLASH COMMAND PROCEDURE

1. Activate the **MINIMUM RECALL** input to the controller to ensure cycling prior to transferring to flashing operation.
2. Omit all non-actuated and actuated artery advance phases.
3. Omit phases 1 & 5 of all quad sequences.
4. Activate the **STOP TIME** input to the controller, upon entering flash, to prevent cycling.
5. Transfer to flash at the end of the last side street all red condition (at the point the artery **ON** output becomes active).
6. Special technical notes on the intersection plan supercede the above requirements.

TC/TBC INSTALLATION REQUIREMENTS

The following requirements are to be observed when engineering the installation of TC/TBC:

1.
 - a. Circuit 1 shall be designated FLASH and be reserved for night flash command.
 - b. Circuit 2 shall be designated MAX 2 and be reserved for Max 2 command.
 - c. Circuit 3 shall be designated COORD and shall select coordinated operation of the intersection.
 - d. Circuit 4 shall be the yield, and force off command to the controller.
2. All clock outputs shall be active to select the function specified. For example; If the TC/TBC were removed for repair, no inputs would be applied to the controller. The intersection will then operate non-coordinated, in Max 1. Programming the TC/TBC without cycle and offset is not an acceptable method to create a non-coordinated operation. Refer to the typical hookup diagram.
3. All TC/TBC clock installations shall be wired as detailed in figure 1. This method is used for both full and semi actuated operation.
4. Midnight resync shall occur at 12:00 AM.
5. A program card shall be completed indicating all input steps and settings. Four copies shall be provided. One copy left in the cabinet. Three delivered to the engineer along with the cabinet wiring diagrams.

TIME CLOCK / TIME BASE COORDINATION

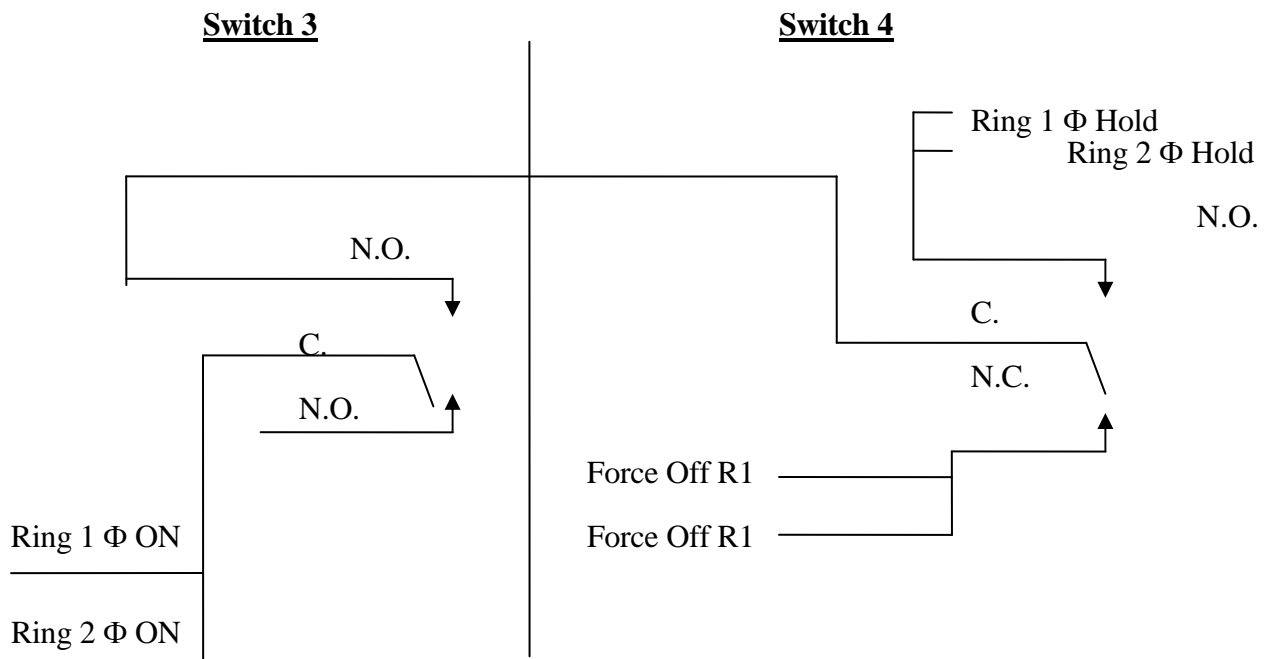

FIG. 1

24 VOLT RELAY

All 24 Volt relays shall meet the requirements of one of the following two types. Diodes shall be installed across the coils of all direct current relays to shunt the reverse voltage generated when the coil de-energizes. All diodes shall be general purpose ECG 125 1000prv @ 25A or equivalent, rated at least .5 amp forward biased. Diodes shall be external to the relay, not enclosed in the dust cover.

TYPE A: Midland Ross, Midtex 155-92 or equivalent.

DESCRIPTION:

This relay shall be enclosed in a clear polycarbonate removable dust cover. It shall have a mechanical life of more than 100,000 operations at rated load.

CONTACTS:

The contacts shall be 2 form C (D.P.D.T), U.L. rated at 5 amps 120 volts A.C. The contacts shall be pure fine silver (gold flash). There shall be no tungsten (lamp) load on the contacts of this relay.

COIL: The coil shall operate on 24 V.D.C. and have no less than 450 OHMS impedance.

SIZE: The relay shall be no larger than 65mm(2.5") H x 40mm(1.5") L x 40mm(1.5") W.

BASE: This relay shall have an eight pin octal plug-in base with the pin designation shown below:

1. Common (1)
2. Coil
3. Normally open (1)
4. Normally closed (1)
5. N.C. (2)
6. N.O. (2)
7. Coil (2)
8. Comm.

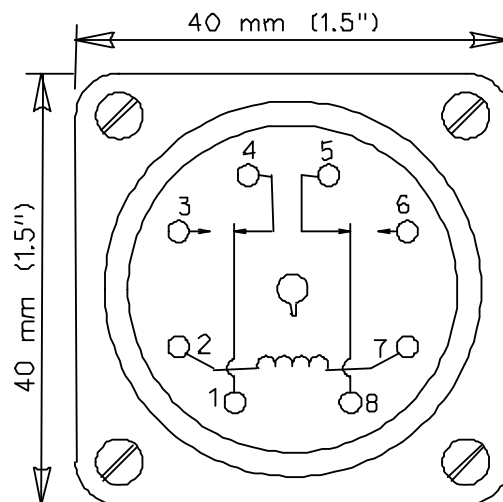

Bottom View And Wiring Diagram

SOCKET: The socket shall be a closed back, screw terminal type. The front mounted screws shall be 6-32 capable of accepting #14 AWG wire.

110 VOLT RELAY

All 110 volt relays shall meet the requirements of one of the following two types. Across the coil of each relay there shall be a molded suppressor rated at .1uf - 47 ohm @ 600V to suppress electrical noise created by the energization / de-energization of the relay.

TYPE F: Midland Ross, Midtex 136-62T3A1 or equivalent

DESCRIPTION:

Relays of this type shall function as flash transfer, power switching and signal drive. Other uses are acceptable, however, type G relays cannot be used for the above applications.

CONTACTS:

The contacts shall be in the D.P.D.T. form and consist of 10mm(3/8") diameter silver cadmium oxide, rated at 20 Amps @ 117 VAC resistive.

COIL:

The coil shall operate on 110 VAC. No semi-conductors will be allowed in the coil circuit of this relay.

SIZE:

The relay shall be enclosed in a clear plastic dust cover. The overall dimensions shall be no larger than 63mm(2 1/2") x 94mm(3 3/4") x 47mm(1 7/8") as illustrated below.

BASE:

This relay shall have an eight blade plug-in base, Ventron Beau Plug P-5408 or equivalent with the pin designations as shown below:

1. Coil
2. Coil
3. N.C. 1
4. N.C. 2
5. Comm. 1
6. Comm. 2
7. N.O. 1
8. N.O. 2

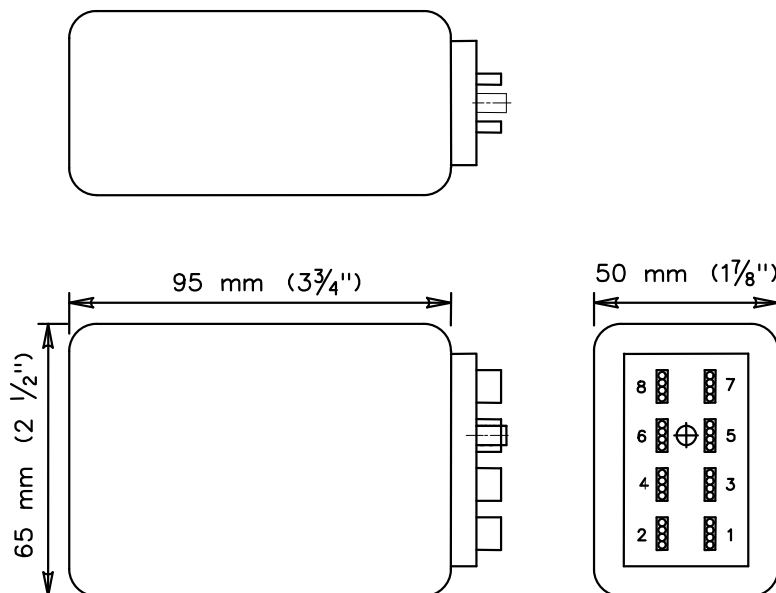

SOCKET:

The socket shall be Ventron Beau Plug S-5408 or equivalent, contacts rated at 15 Amps @ 1750 VRMS.

TYPE G: Magnecraft, W 88 ACXP-8 or equivalent

DESCRIPTION:

Relays of this type shall function in low current switching applications such as interconnect interface or pre-emption circuits. A clear polycarbonate plastic enclosure shall cover the relay mechanism.

CONTACTS:

The contacts shall be in the D.P.D.T. form and consist of 5mm (3/16") diameter gold flashed, silver alloy, rated at 10 Amps @ 120 VAC resistive.

COIL:

The coil shall operate on 120 Volts AC and require a nominal 3 VA.

SIZE:

Height, length and width dimensions shall be the same as the 24 volt relay Type A: 35mm(1 3/8") x 60mm(2 3/8") x 35mm(1 3/8").

BASE:

The base shall be an octal plug with the pin designations the same as the 24 volt relay Type A.

SOCKET:

The socket shall be the same as that for the 24 volt relay Type A.

TIME DELAY RELAY

120 VAC SSAC TDM120A or equivalent
24 VDC SSAC TDM24DL or equivalent

DESCRIPTION:

The time delay relays shall be self enclosed, plug-in, delay on operate type. They shall be digitally timed and adjustable by the use of dip switches located on the top of the case. The timing range shall be 1 to 1023 seconds in 1 second intervals. The time delay relays shall have an internal double pole double throw relay with form "C" contacts rated at 10 amps 120 volts AC. They shall operate accurately in a temperature range of -20 to +65 degrees C. A 120 volt AC input shall initiate timing of the 120 VAC TDR and a 24 VDC input shall initiate timing of the 24 VDC TDR. Removal of the input voltage shall reset the timer. Maximum dimensions of the case shall be as shown below.

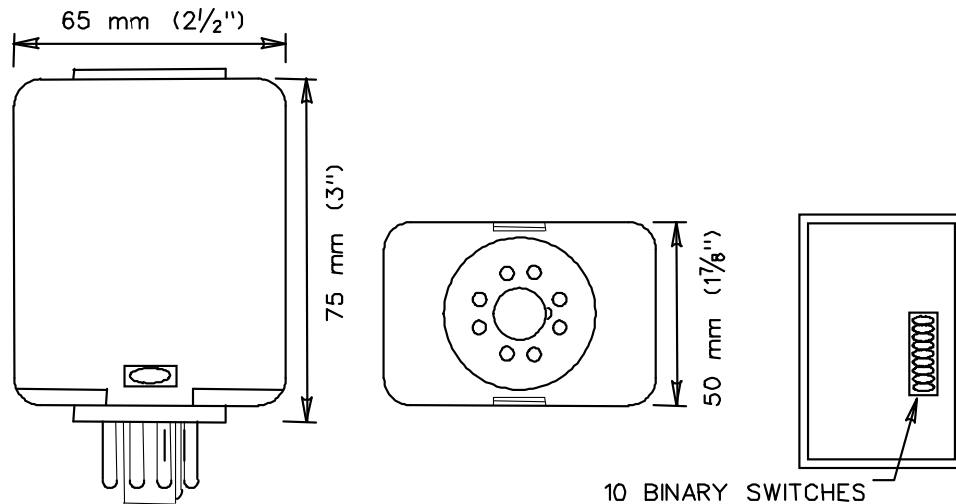

SOCKET:

The socket shall be a standard octal base (8 pin) with screw terminal connectors. The pin designation shall be as shown below.

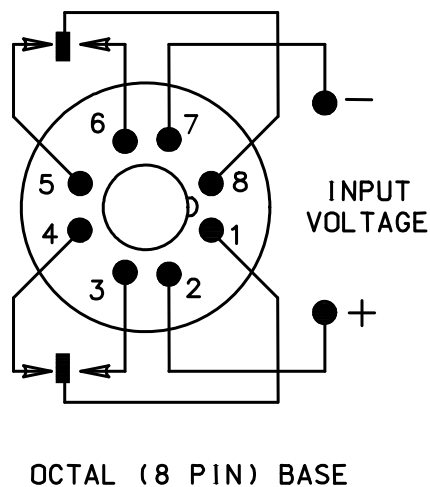

NON-ACTUATED ADVANCE GREEN PHASE

Where the timing and sequence indicates an advance green phase that always precedes the phase in recall (usually phase 2), and that either is fixed timed or is to be extended only, the following guidelines shall be in effect:

1. The parent phase ON output shall be diode connected to the advance phase OMIT input.
2. If the advance phase is to be extendable, it shall be in minimum recall. If the advance phase is fixed timed, it shall be in maximum recall. A different advance time may be selected by switching to maximum 2.

Example: Phase 1 is the advance phase (extendable), in minimum recall.
Phase 2 is the artery, in recall.
Phase 4 is the minor street, in non-lock.

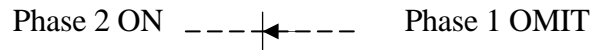

Where the timing and sequence indicates an advance phase that is fixed timed (not extendable), and that always precedes either a phase other than phase 2 or a phase not in recall, the following guidelines shall be in effect:

1. The recall phase (usually Phase 2) ON output shall be diode connected to the advance phase's, parent phase OMIT input.
2. The parent phase CHECK output shall be diode connected to the advance phase vehicle detector input.
3. The advance phase ON output shall be diode connected to the following parent phase vehicle detector input. This is to insure a green indication on the parent phase.
4. The advance phase shall be in the non-lock mode. The advance time shall be selected from the maximum interval.

Example: Phase 2 is the artery, in recall.
Phase 3 is the advance for phase 4, in non-lock mode.
Phase 4 (parent phase) is the minor street, in non-lock mode.

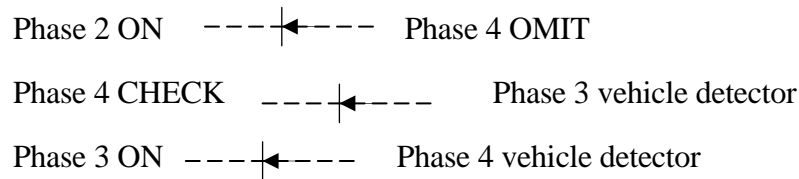

ACTUATED ADVANCE GREEN

Where the timing and sequence indicates an advance green phase that is to be extended only, and is to always precede either a phase other than phase 2 or a phase not in recall, the following guidelines shall be in effect:

1. The phase ON outputs of all phases that could precede the advance phase, shall be diode connected to the parent phase OMIT input.
2. The parent phase CHECK output shall be diode connected, through the normally closed contacts of a relay, to the advance phase vehicle detector input. The advance phase loop detector output shall be connected to the normally open contacts.
3. The relay coil shall be energized by the advance phase ON output, which in turn will switch the vehicle detector input from the parent phase CHECK circuit to the loop detector.
4. The advance phase ON output shall be diode connected to the following parent phase vehicle detector input. This is to insure a green indication from the parent phase.
5. The advance phase shall be in the non-lock mode.

Example: Phase 2 is the artery, in recall.
Phase 3 is the pedestrian phase.
Phase 4 is the advance for phase 5, in non-lock.
Phase 5 (parent phase) is the minor street, in non-lock.

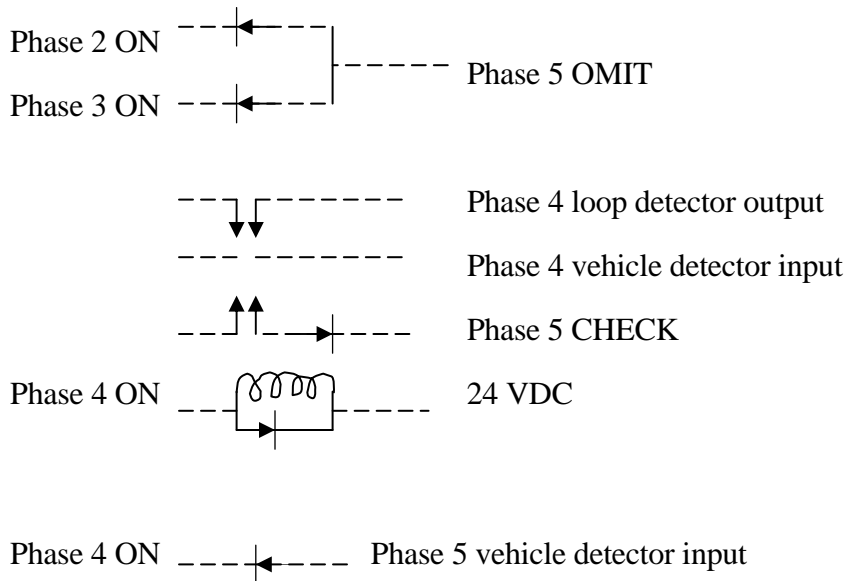

The 24 volt relay shall be Type C as previously described in these specifications.

NON-ACTUATED CLEARANCE PHASE

NON-ACTUATED LAG GREEN PHASE

Where the timing and sequence indicates a non-actuated clearance phase or a lagging green phase that always follows the phase in recall, the following guidelines shall be in effect:

1. The parent phase ON output shall be diode connected to all appropriate phase OMIT inputs except the clearance phase.
2. The remaining actuated phases shall have their CHECK outputs diode connected to the clearance phase vehicle detector input.
3. The clearance phase ON output shall be diode connected to the following phases vehicle detector input (if the phase is in non-lock mode). This will prevent the controller from returning to the parent phase from the clearance phase without servicing the minor street.
4. The clearance phase shall be in the non-lock mode.
5. The clearance, or lag green time shall be selected from the maximum interval.

Example: Phase 2 is the artery, in recall.
Phase 3 is the clearance phase, in non-lock.
Phase 4 is the pedestrian phase.
Phase 5 is the minor street, in non-lock.

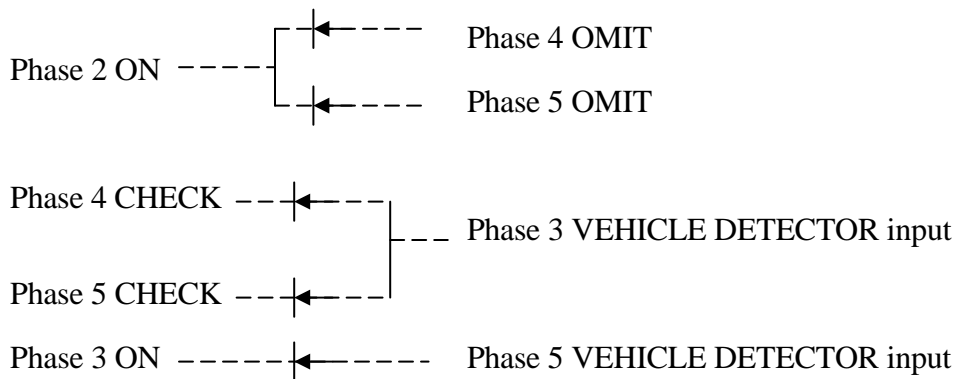

Where the timing and sequence shows a non-actuated clearance phase or lagging green phase following either a phase other than phase 2 or a phase not in recall, the following guidelines shall be in effect:

1. The parent phase ON output shall be diode connected to the following clearance phase vehicle detector input. This insures the clearance phase will always follow the parent phase.
2. The clearance phase shall be in the non-lock mode.
3. The clearance, or lag green time shall be selected from the minimum green interval.



ACTUATED CLEARANCE PHASE

ACTUATED LAG GREEN PHASE

Where the timing and sequence indicates an actuated lagging green phase that is to be extended only, and always follows another phase, the following guidelines shall be in effect:

1. The parent phase (usually phase 2) ON output shall be diode connected to the phase OMIT inputs of all phases that could follow the lag phase.
2. The CHECK outputs of all phases that could follow the lag phase shall be diode connected, through the normally closed contacts of a relay, to the lag phase vehicle detector input. The lag phase loop detector output shall be connected to the normally open contacts.
3. The relay coil shall be energized by the lag phase ON output which in turn will switch the phase detector input from the CHECK circuits to the loop detector.
4. The lag phase shall be in the non-lock mode.

Example: Phase 2 (parent phase) is the artery, in recall.
Phase 3 is the lag phase, in non-lock.
Phase 4 is the pedestrian phase.
Phase 5 is the minor street, in non-lock.

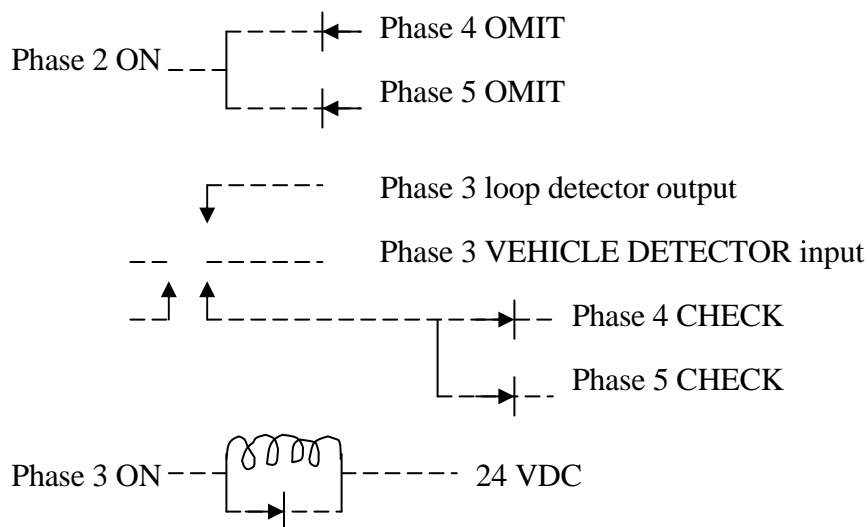

The 24 VDC relay shall be Type C as previously described in these specifications.

FLASHING STOP AHEAD SIGN

Where the timing and sequence indicates a flashing stop ahead sign, the clearance interval following the phase that the sign is off shall be timed by the following method.

The following phase shall be used for the clearance time. These phases shall be overlapped. The green indication will be maintained by the overlap feature and the following phase green time will be the stop ahead sign clearance.

The artery phase ON output shall be diode connected to all other phase OMIT inputs except the clearance phase and the artery phase. The CHECK outputs from the remaining phases (as needed) shall be diode connected to the sign clearance phase vehicle detector input. The clearance phase shall be in the non-lock mode.

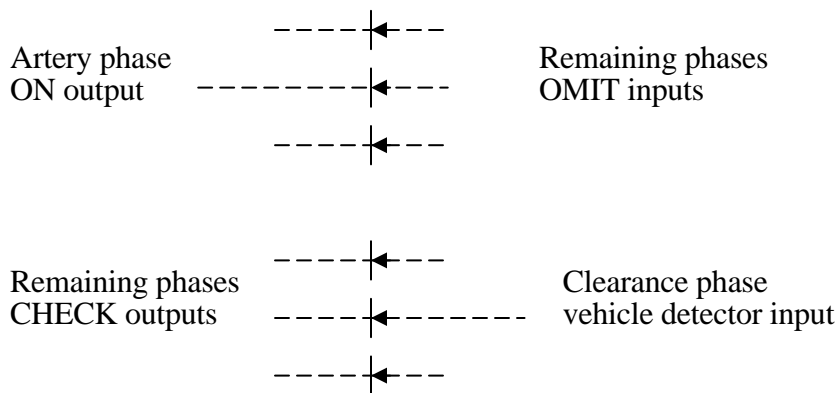

If the non-artery phases are in the non-lock mode, a call must be forced to the non-artery phase once the controller leaves the artery Hold interval (either artery walk or artery green). This prevents a false "Stop Ahead" indication if a vehicle turns right on red during the flashing sign clearance interval.

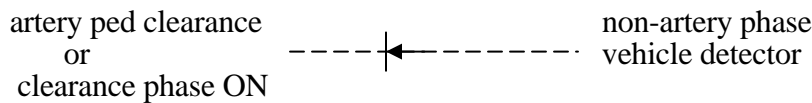

Unless otherwise shown on the plans, the 110 VAC flash power shall be from a spare load switch in the controller cabinet. The load switch input shall be driven with the flashing logic output from the controller. The flashing logic output shall be disconnected from the load switch during the intervals the sign is inactive.

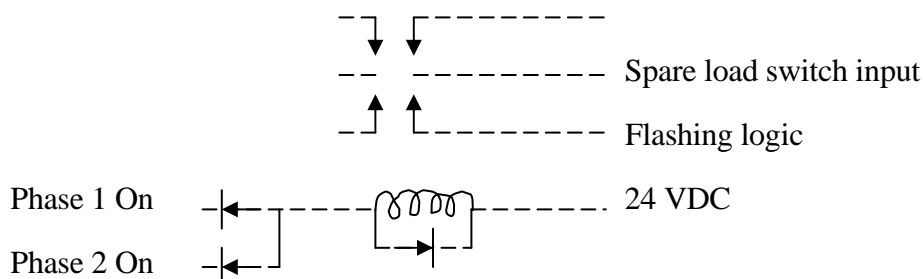

Typical drive circuit for "WHEN FLASHING STOP AHEAD" sign

TIME BASE COORDINATION MAX II ACTUATION BY PEDESTRIAN CALL

When the sum of the split times, including the walk and don't walk, exceed the background cycle length, the designer may choose to either allow a double cycle of the background timer or reduce the phase timings when the ped phase is called. Reduction of the phase timing by switching to MAX 2 avoids double cycling.

Where indicated on the plans the exclusive pedestrian phase will call MAX II. The minor movement max 2 times are set low so that the total phase times do not exceed the coordination cycle length.

Install a 24 volt relay connected to the inputs and outputs as shown on the following schematic.

Operation: When the controller advances to the exclusive pedestrian phase, the relay is actuated and latched. MAX II timing is selected for one complete cycle, until the relay is unlatched by the artery yellow (absence of red or green).

Example: Phase 2 is the artery. Phase 3 is the exclusive pedestrian phase.

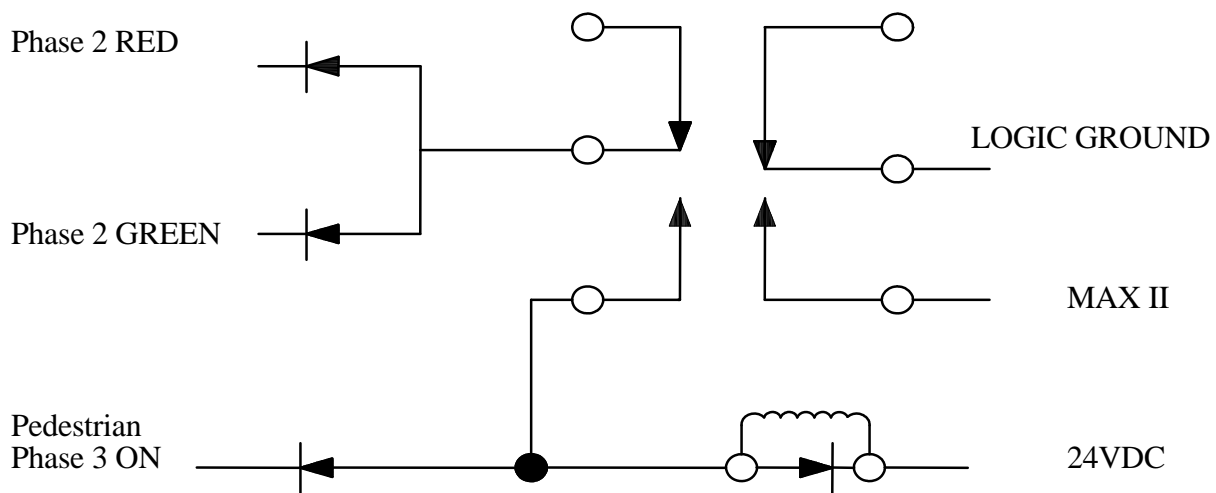

ITEM #1108207A - INSTALL STATE FURNISHED TRAFFIC CONTROLLER AND CABINET

Description:

This item shall consist of installing a traffic controller cabinet, and related equipment, furnished by the State, Department of Transportation, on an existing, modified, or new foundation as indicated on the plans or as directed by the Engineer.

Material:

All material for this work shall be furnished by the State except for miscellaneous electrical hardware, such as spade connectors, electrical tape, and cable ties required to complete the installation.

Construction Methods:

The Contractor shall arrange a schedule to pick up the traffic controller, cabinet, and related material from the Department of Transportation, Electronics Lab, Unit 1511, located at 280 West Street in Rocky Hill. Contact Mr. James Nesci 45 days in advance to schedule pick up of the material. In addition, the Contractor shall telephone 24 hours prior to the scheduled date to confirm the location and time of pick up. Telephone (860) 258-0347 or (860) 258-0346.

The Contractor shall sign a receipt, listing all material furnished by the State, for each location. All material provided by the State shall be transported, and stored if necessary, with care appropriate for microprocessor electronic equipment. It shall be the Contractor's responsibility from the time of pick up until the new controller is in operation according to plan, to repair or replace any material damaged during delivery or during installation.

The Contractor shall develop a schedule of the dates of the installation of each State furnished controller. The Contractor shall keep the Engineer advised of the schedule and any subsequent changes. The Engineer shall notify the D.O.T., District Electrical Maintenance Office and the D.O.T. Electronics Lab of the schedule and all changes to the schedule.

It shall be the responsibility of the Contractor to determine the function of existing traffic signal, pedestrian signal and detector cables, which will be reused, so that correct connection to the new controller may be completed.

The cabinet shall be installed on the foundation in accordance with the plans or as directed by the Engineer. Prior to connection of the field wires to the new controller cabinet, the Contractor shall perform the following tests:

1. Flash out all traffic and pedestrian signal field wires. This shall consist of momentarily connecting each to a 110 VAC fused source. This will ensure the signals are connected to the correct wires and there are no shorts in the field wiring.

2. Voltage test all input circuits. This shall consist of measuring all other field wires, such as vehicle detector, pedestrian pushbutton and pre-emption cables with a volt meter to ensure there is no voltage present which will damage the electronic devices.

Only then will existing and new signal wires and detector cables be connected, as indicated in the signal hook up chart provided with each cabinet.

When secondary service is initially applied to a State furnished controller cabinet, the controller unit, conflict monitor, coordination unit and other electronic equipment shall be unplugged. After the signals are flashing, the controller, conflict monitor and other equipment shall be connected, and the intersection placed in automatic operation.

Method of Measurement:

This work shall be measured for payment by the number of traffic controllers, cabinets and related equipment for each, picked up, installed, operating and accepted in place.

Basis of Payment:

This work will be paid for at the contract unit price each for "INSTALL STATE FURNISHED TRAFFIC CONTROLLER AND CABINET" complete in place, which shall include transportation from the pick up source to the location, storage, all miscellaneous electrical hardware, tools and work incidental thereto.

ITEM #1108645A - AUXILIARY TERMINATION CABINET

Description:

This item will consist of furnishing and installing an Auxiliary Termination Cabinet (ATC), on a traffic control cabinet at the location shown on the plans and in accordance with the conditions set forth.

Materials:

Each ATC shall be made of type 5052-H32, 3.175mm (.125) sheet aluminum with a finish painted in accordance with the current D.O.T. specifications of Traffic Control Cabinets. The ATC shall be of clean-cut design and appearance. All seams shall be continuously welded and ground smooth. The ATC shall have dimensions as shown on the plans and shall conform to the NEMA 4X enclosure specifications. There shall be a 3.175mm (1/8") metal plate mounted on the back wall, spaced approximately 19.05mm (3/4") from the back wall, for equipment provided and installed by SNETCO. The door shall have two quarter-turn latches with a hasp and staple for padlocking. An oil resistant gasket shall seal the door. Door hinge pins shall be stainless steel material. All hardware used in the mounting of these cabinets shall be rust and corrosion resistant.

Construction Methods:

The ATC shall be mounted on the left side of the controller cabinet, when facing the door, as indicated on the Typical Installation Detail Sheet. An opening shall be made in the ATC corresponding to the size of the conduit entering from the bottom as shown on the plan. An insulated bushing shall be installed on the conduit. A 31.75mm (1 1/4 ") hole shall be made in the back of the ATC and through the side of the controller cabinet. A close nipple with insulated bushings shall be installed through the hole. The Contractor shall confirm the inside of the cabinet wall is clear, so that installation of the ATC will not damage any equipment inside the controller cabinet. A continuous nylon pull rope of at least 90.72 Kg (200 lbs.) breaking strength, shall be installed in the 31.75mm (1 1/4") conduit from the inside of the ATC to the SNET facilities. Four feet of slack shall be coiled and tied at each end to prevent removal until the installation of SNET cable.

Method of Measurement:

This item shall be measured for payment by the actual number of Auxiliary Termination Cabinets installed and accepted on traffic control cabinets.

Basis of Payment:

This item shall be paid for at the contract unit price each for "Auxiliary Termination Cabinet" which price shall include mounting hardware, close nipple, insulated bushings, pull rope, tools, and incidentals.

ITEM #1108722A – VEHICLE EMITTER

ITEM #1108724A - PHASE SELECTOR

ITEM #1112410A - DETECTOR (TYPE A)

ITEM #1112470A - PRE-EMPTION SYSTEM CHASSIS

ITEM #1113550A - DETECTOR CABLE (OPTICAL)

SYSTEM DESCRIPTION:

The emergency vehicle traffic signal priority control system shall enable designated vehicles to remotely cause the traffic signal controller to advance to and/or hold a desired traffic signal display by using existing controller functions. The control shall be activated at a minimum distance of 548.6M (1,800 feet) along an unobstructed "line of sight" path. The control shall not terminate until the vehicle is within 12.2M (40 feet) of the detector or at the intersection.

The system shall consist of the following components:

- A. Vehicle Emitter which shall be mounted on the emergency vehicle and shall transmit optical energy signals only in the forward direction. If the municipality presently uses optical pre-emption, the emitters shall be of the same manufacture currently used by the Town.
- B. Phase Selector (minimum 2 channel) which shall cause the signal controller to advance to and/or hold the desired traffic signal display for the emergency vehicle. A pre-emption system chassis shall house two phase selectors.
- C. Optical Detector which shall be mounted on or near a traffic signal and shall receive the optical energy signals generated by the Vehicle Emitter.
 - 1. Detector (Type A), 1 Direction, 1 Channel
 - 2. Detector (Type B), 2 Direction, 1 Channel
 - 3. Detector (Type C), 2 Direction, 2 Channel
- D. Detector Cable (Optical).

System Operation:

- A. The operating sequence shall be initiated when the optical detector receives the required optical energy signal from the Emitter.

- B. The phase selector shall cause the traffic signal controller to advance to and/or hold the desired traffic signal display for the emergency vehicle.
- C. The phase selector shall cause the controller to advance to and/or hold the desired traffic signal display even if the optical energy signals cease before the desired display is obtained.
- D. The phase selector shall allow the traffic signal controller to resume normal operation within ten seconds after optical energy signals cease if the optical energy signals cease after the desired traffic signal display is obtained.
- E. The phase selector shall not respond to optical energy signals from an emergency vehicle if it is already processing optical energy signals from another emergency vehicle.

System Components:

A. Vehicle Emitter:

The emitter assembly consists of an emitter and power supply and an emitter control switch assembly. The emitter assembly is mounted on a vehicle and produces a flashing optical signal when in operation.

1. Shall operate on ten to fifteen volts DC input voltage, but shall not be damaged by input voltage surges up to twenty-five volts DC.
2. Shall be controlled by a single on/off switch that requires no other adjustments by the operator. The on/off condition shall be indicated by a light located adjacent to the switch.
3. Shall be automatically disabled or de-activated by one or a combination of the following: seat switch, emergency brake switch, door switch, transmission safety switch.
4. Shall operate over an ambient temperature range of minus 34⁰ C to plus 60⁰ C. (minus 30⁰ F. to plus 140⁰ F.)
5. Shall operate in 0 to 95 % humidity.
6. Shall be a pulsed optical energy source with a controlled repetition rate.
7. Shall not generate voltage transients on the battery input line which exceed battery voltage by more than four volts.
8. Shall produce optical energy in a cone of not more than 90 degrees horizontal and not more than 30 degrees vertical. The detectors and/or phase selector shall not sense a pre-emption signal from an emitter outside this cone.

B. Optical Detector:

The optical detector receives the high intensity optical pulses produced by the emitter. These optical energy pulses are transformed by the detector into appropriate electrical signals which are transmitted to the phase selector. The optical detector is mounted at or near the intersection in a location which permits an unobstructed line of sight to vehicular approaches. The units may be mounted on signal span wires, mast arms or other appropriate structures.

1. Shall be of solid state construction.
2. Shall operate over an ambient temperature range of minus 34⁰ C to plus 60⁰ C. (minus 30⁰ F. to plus 140⁰ F.)
3. Shall have internal circuitry potted in a semi-flexible compound to ensure moisture resistance.
4. Shall operate in 0 to 95 % humidity.
5. Shall have a cone of detection of not more than 13 degrees. The detector and/or phase selector shall not sense a pre-emption signal from an emitter outside this cone.

C. Phase Selector:

The phase selector supplies power to and receives electrical signals from the optical detector. When detector signals are recognized as a valid call, the phase selector causes the signal controller to advance to and/or hold the desired traffic signal display. This is accomplished by activating the pre-empt input to the controller.

The phase selector is capable of assigning priority traffic movement to one of two channels on a first-come, first-serve basis. Each channel is connected to select a particular traffic movement from those normally available within the controller. Once a call is recognized, "commit to green" circuitry in the phase selector functions so that the desired green indication will be obtained even if optical communication is lost. After serving a priority traffic demand, the phase selector will release the controller to follow normal sequence operation.

1. Shall include an internal power supply to supply power to the optical detectors.
2. Shall have minimum two-channel operation with the capability of interfacing with an additional phase selector for expansion of channels of operation.
3. Shall have adjustable detector range controls for each channel of operation, from 12M (40 feet) to 548M (1800 feet).
4. Shall have solid state indicator lights for power on and channel called.
5. Shall operate over an ambient temperature range of minus 34⁰ C to plus 60⁰ C (minus 30⁰ F. to plus 140⁰ F.)
6. Shall operate in 0 to 95 % humidity.

D. Detector Cable (Optical):

1. 3-Conductor cable with shield and ground wire.
2. AWG #20 (7x28) stranded.
3. Individually tinned copper strands.
4. Conductor insulation: 600 volt , 75 deg. C (167^O F.).
5. 1 Conductor-yellow; 1 Conductor-blue; 1 Conductor-orange.
6. Aluminized mylar shield tape or equivalent.
7. AWG #20 (7x28) stranded uninsulated drain wire
8. DC resistance not to exceed 11.0 ohms per 305M(1000 feet).
 - 9.Capacitance from one conductor to other two conductors and shield not to exceed 157pf/M (48 pf./ft.).
 10. Jacket: 600 volts, 80 deg. C (176^O F.), minimum average wall thickness - 1.14mm (.045").
11. Finished O.D.: 7.62mm (0.3") max.

System Interface:

System shall be capable of operating in a computerized traffic management system when appropriate interfacing is provided by the computer supplier.

General:

The Contractor shall furnish the manufacturer the phasing diagrams indicating controller sequence and timing.

The Contractor shall secure from the manufacturer a guarantee for the equipment for a period of sixty (60) months, which time shall commence from the date of delivery. Manufacturer shall certify upon request that all materials furnished will conform to this specification. The manufacturer or his designated representative shall be responsible for determining and setting all required range and emitter intensity for the emergency vehicle operation.

Construction Methods:

All equipment except the vehicle emitter assembly shall be installed and wired in a neat and orderly manner in conformance with the manufacturers' instructions. The vehicle emitter assembly shall be delivered to a designated town representative. Installation of the vehicle emitter assembly shall be the responsibility of the town.

Traffic signals owned and maintained by the State that have optical pre-emption equipment owned and maintained by the town shall have an Auxiliary Equipment Cabinet (AEC) attached to the controller cabinet. The optical pre-emption equipment shall be housed in the AEC. Traffic signals owned and maintained by the town do not require an AEC to house the pre-emption equipment.

Detector cables shall be continuous with no splices between the optical detector and the AEC.

Detector locations shown on the plan are for illustration purposes only. Exact location shall be determined by the contractor or the designated representative for the best possible line of sight.

If not present in an existing traffic controller cabinet, the following items shall be installed and connected, in conformance with the current Functional Specifications for Traffic Control Equipment, “D” Cabinet Requirements (Pre-emption Type):

- Controller “D” harness and adapter.
- Pre-emption termination panel with terminal block and relay bases.
- Pre-emption disconnect switch, mounted on the emergency switch panel (on inside of cabinet door).
- Pre-emption test buttons, mounted on the pre-emption termination panel.

All connections from the phase selector to the “D” harness and to the cabinet wiring shall be made at the termination panel. The termination panel shall have AC+ Lights, AC-, and a switched logic ground. The switched logic ground feeds all the pre-empt inputs to the phase selector. When switched off by the pre-emption disconnect switch, the traffic controller shall not be affected by pre-empt calls from the optical pre-emption system. A minimum of two test buttons shall be provided. If there are more than two pre-empt runs, a button for each shall be installed. A chart or print out indicating the program steps and settings shall be provided along with the revised cabinet wiring diagrams.

Test the Pre-emption System According to the following Guidelines:

1. Notify the system owner/user, such as the municipal fire chief or public works director, of the scheduled inspection
2. Request a fire department representative and an emergency vehicle, which has an emitter to conduct the test. If not available, the contractor shall provide an emitter.
3. In the presence of the Engineer and the municipal representative, test each pre-empted approach with the emergency vehicle. Test the following items of the system:
 - * Confirm that the emitter activates the phase selector and the phase selector activates the correct pre-emption input to the controller.
 - * Confirm adequate range. The traffic signal must be pre-empted to green sufficiently in advance of the emergency vehicle arrival. The vehicle emitter shall initiate pre-emption at a minimum distance of 548.6M (1800 feet).
 - * Confirm there are no false calls. Keep the emitter active as the emergency vehicle passes through the intersection. No other optical detectors shall sense the strobe.
4. Document the test. Provide the Engineer and, upon request, the municipality copies of the test results.

If a malfunction is found or the system needs adjustment (such as range, emitter intensity, or detector location), schedule a follow-up test. Repeat the above steps for all approaches that did not pass.

All adjustments such as emitter intensity, phase selector range, sensitivity, detector placement, shall be made at the intersection by the contractor so that the optical pre-

emption operates correctly with other major manufacturers' equipment currently owned by the town.

Method of Measurement:

Optical Detectors, Phase Selectors, System Chassis will be measured for payment by the number of each supplied, installed and accepted. Detector Cable (Optical) will be measured by the number of meters (linear feet) supplied, installed and accepted. Vehicle Emitters will be measured by the number of each supplied to the Town and accepted.

Basis of Payment:

Payment for Optical Detectors, Phase Selector, System Chassis and Detector Cable (Optical) will include the item unit cost, including all manufacturer's required mounting hardware and the cost of installation and supervision by the manufacturer or his designated representative, including travel and subsistence, and all materials, equipment and labor incidental thereto. Payment for termination panel, "D" harness, test buttons, program chart (or print out) and revised cabinet wiring diagrams shall be included in the item PRE-EMPTION SYSTEM CHASSIS. Payment for Vehicle Emitters will include the item unit cost only.

<u>Pay Items</u>	<u>Pay Units</u>
Vehicle Emitter	Ea.
Detector (TYPE)	Ea.
Phase Selector	Ea.
Detector Cable (Optical)	M.(L.F.)
Pre-Emption System Chassis	Ea.

ITEM #1111401A - LOOP VEHICLE DETECTOR

ITEM #1111451A - LOOP DETECTOR SAWCUT

Replace Section 11.11, LOOP VEHICLE DETECTOR AND SAWCUT, with the following:

11.11.01 – Description:

1. Furnish and install a loop vehicle detector amplifier.
2. Sawcut pavement. Furnish and install loop detector wire in sawcut.

11.11.02 – Materials:

Article M.16.12

M.16.12 - LOOP VEHICLE DETECTOR AND SAWCUT

1. Loop Vehicle Detector:

- Comply with National Electrical Manufacturers Association (NEMA) standards, Section 6.5, Inductive Loop Detectors.
- Comply with the current CT DOT Functional Specifications for Traffic Control Equipment, Section 3 B, Loop Vehicle Detector With Delay/Extend Option.

2. Sawcut:

(a) Wire in sawcut:

- International Municipal Signal Association (IMSA) Specification 51-7, single conductor cross-linked polyethylene insulation inside polyethylene tube.
- # 14 AWG

(b) Sealant:

(1) Polyester Resin Compound

- Two part polyester which to cure, requires a liquid hardener.
- Use of a respirator not necessary when applied in an open air environment.
- Cure time dependent on amount of hardener mixed.
- Flow characteristics to guarantee encapsulation of loop wires.
- Viscosity: 4000 CPS to 7000 CPS at 77 degrees Fahrenheit (25° C).
- Form a tack-free skin within 25 minutes and full-cure within 60 minutes at 77 degrees Fahrenheit (25° C).
- When cured, resist effects of weather, vehicular abrasion, motor oil, gasoline, antifreeze, brake fluid, de-icing chemicals, salt, acid, hydrocarbons, and normal roadway encounters.
- When cured, maintain physical characteristics throughout the ambient temperature ranges experienced within the State of Connecticut.
- When cured, bonds (adheres) to all types of road surfaces.
- Weight per Gallon (3.8 l): 11 lbs ±1 lb (5kg ± .45kg)

- Show no visible signs of shrinkage after curing.
- 12 month shelf life of unopened containers when stored under manufacturers specified conditions.
- Cured testing requirements:
 - Gel time at 77 degrees F (25° C): 15 - 20 minutes, ASTM C881, D-2471
 - Shore D Hardness at 24 hours: 55-78, ASTM D-2240
 - Tensile Strength: > 1000 psi (6895 kPa), ASTM D-638
 - Elongation: 18 - 20 %, ASTM D-638
 - Adhesion to steel: 700 - 900 psi (4826 - 6205 kPa), ASTM D-3163
 - Absorption of water, sodium chloride, oil, and gasoline: < 0.2%, ASTM D-570
- Include in the Certificate of Compliance:
 - Manufacturer's confirmation of the uncured and cured physical properties stated above.
 - Material Safety Data Sheet (MSDS) stating sealant may be applied without a respirator in an open air environment.
- Designed to allow clean-up without the use of solvent that is harmful to the workers and the environment.

(2) Elastomeric Urethane Compound:

- One part urethane which to cure, does not require a reactor initiator, or a source of thermal energy prior to or during its installation.
- Use of a respirator not necessary when applied in an open air environment.
- Cure only in the presence of moisture.
- Flow characteristics to guarantee encapsulation of loop wires.
- Viscosity such that it does not run out of the sawcut in sloped pavement during installation; 5000 CPS to 85,000 CPS.
- Form a tack-free skin within 24 hours and 0.125 inch (0.33mm) cure within 30 hours at 75 degrees Fahrenheit (24° C).
- When cured, resist effects of weather, vehicular abrasion, motor oil, gasoline, antifreeze, brake fluid, de-icing chemicals, salt, acid, hydrocarbons, and normal roadway encounters.
- When cured, maintain physical characteristics throughout the ambient temperature ranges experienced within the State of Connecticut.
- Show no visible signs of shrinkage after curing.
- Shelf life when stored under manufacturers specified conditions:
 - Caulk type cartridges: minimum 9 months
 - Five gallon containers: minimum 12 months
- Designed for application when the pavement surface temperature is between 40 and 100 degrees Fahrenheit (4° and 38° C).
- Uncured testing requirements:
 - Weight/Gallon: ASTM D-1875
 - Determination of Non-volatile Content: ASTM D-2834
 - Viscosity: ASTM D-1048B
 - Tack-free Time: ASTM D-1640
- Cured testing requirements:
 - Hardness: ASTM D-2240
 - Tensile Strength & Elongation: ASTM D-412A
- Include in the Certificate of Compliance:
 - Manufacturer's confirmation of the uncured and cured physical properties stated above.
 - Material Safety Data Sheet (MSDS) stating sealant may be applied without a respirator in an open air environment.

- Designed to allow clean-up without the use of solvent that is harmful to the workers and the environment.

3. Miscellaneous:

- (a) Liquidtight Flexible Nonmetallic Conduit
 - UL listed for direct burial
 - UL 1660
 - Smooth polyvinyl chloride inner surface
- (b) Water Resistant Pressure Type Wire Connector
 - UL listed for direct burial and wet locations
 - UL 486D

11.11.03 - Construction methods:

1. Loop Vehicle Detector

- Shelf-mount the detector amplifier in the controller cabinet.
- Terminate the harness conductors with crimped spade connectors. Connect conductors to appropriate terminals, eg, black wire to 110vac, white wire to 110vac neutral.
- Tie loop harness and conductors to controller cabinet wiring harness. Leave enough slack in loop harness so that amplifier may be moved around on cabinet shelf; ± 2 feet (0.6 meter) slack.
- Attach a loop identification tag to the harness. Record pertinent detector information on the tag with indelible ink. See example below.
 - Loop No.: *D4*
 - Phase Call: *Phase 4*
 - Field Location: *Rt. 411(West St.)*
 - *Eastbound, Left Lane*
 - Detector No.: *4*
 - Cabinet Terminals: *234, 235*

2. Loop Detector Sawcut

- Loop size, number of turns, and location is shown on the intersection plan.
- Do not cut through a patched trench, damaged or poor quality pavement without the approval of the Engineer.
- Wet-cut pavement with a power saw using a diamond blade $\frac{3}{8}$ inch (9.5mm) wide. Dry-cut is not allowed.
- Ensure slot depth is between 1 $\frac{3}{4}$ inch to 2.0 inch (45mm to 50mm).
- Overlap corners to ensure full depth of cut.
- To prevent wire kinking and insulation damage, chamfer inside of corners that are ≤ 120 degrees.
- Clean all cutting residue and moisture from slot with oil-free compressed air. Ensure slot is dry before inserting wire and sealing sawcut.
- Cut home-run, from loop to curb or edge-of-road, as shown on the typical installation sheet.
- To prevent cross-talk and minimize electrical interference, twist home-run wires, from edge of road to handhole, with at least 5 turns per foot (16 turns per meter). Tape together twisted home-run wires at 2 foot (0.6 meter) \pm intervals.
- In new or resurfaced pavement, install loops in the wearing course. If the wearing course is not scheduled for immediate placement (within 24 hours) after the base course, provide temporary detection when directed by the Engineer. Temporary detection may be sawcut

loops, preformed loops, microwave sensor, video, or other method approved by the Engineer.

- Splice(s) not allowed anywhere in loop wire either in loop or in home-run.
- Ensure wires are held in place at bottom of slot by inserting at 2 foot (0.6 m) intervals, 1 inch sections of foam backer rod or wedges formed from 1 inch (25mm) sections of the polyethylene tubing. Loop detectors with wires that have floated to the top of the sealant will not be accepted.
- To create a uniform magnetic field in the detection zone, wind adjacent loops in opposite directions.
- Use **polyester compound** as the sealant unless another type is allowed by the Engineer.
- Mix hardening agent into polyester resin with a power mixer or in an application machine designed for this type of sealant in accordance with the manufacturer's instructions.
- Apply the loop sealant in accordance with the manufacturer's instructions and the typical installation sheet. Do not apply sealant when pavement temperature is outside the manufacturers recommended application range.
- Solder splice the loop wires to the lead-in cable and install water resistant connector as shown on the typical installation sheet.
- Test the loop circuit resistance, inductance, and amplifier power-interruption as shown on the typical installation sheet. Document all test results.

3. Damaged, Patched, or Excessively Worn Pavement

- Where the existing pavement is damaged, patched or excessively worn and is found to be not suitable for reliable loop detection, notify the Engineer.
- When directed by the Engineer, remove and replace an area of pavement to allow the proper installation of the loop.
- Remove a minimum of 3 inches (75mm) depth.
- Comply with the applicable construction methods of Section 2.02 Roadway Excavation, Formation Of Embankment and Disposal of Surplus Material, and Section 4.06 Bituminous Concrete, such as:
 - Cut Bituminous Concrete
 - Material for Tack Coat
 - Bituminous Concrete Class 1

4. Re-surface/Overlay Project

- Prior to disconnecting the existing loop confirm that the amplifier is operating properly and is programmed according to plan. Document loop operation. Report any discrepancies and malfunctions to Engineer.
- Remove all abandoned sawcut home-run wire from handhole.
- Sawcut new loop according to plan.
- Solder splice new loop wires to the existing lead-in cable and install new water resistant twist connectors as shown on the typical installation sheet. Do not re-use the removed connectors.
- Test the loop circuit resistance and inductance. Document results.
- Ensure the existing loop amplifier has re-tuned to the new loop and is operating according to plan.

11.11.04 – Method of Measurement:

1. Loop Vehicle Detector is measured by the number of installed, operating, tested, and accepted vehicle detector amplifiers of the type specified.
2. Loop Detector Sawcut is measured by the number of linear feet (meters) of installed, tested, operating, and accepted sawcut only where there is loop wire. Over-cuts at corners that do not contain wire are not measured.

11.11.05 – Basis of Payment:

1. Loop Vehicle Detector is paid at the contract unit price each of the type specified.
2. Loop Detector Sawcut is paid at the contract unit price per linear foot (meter). The price includes sawcut, loop wire, sealant, liquidtight flexible nonmetallic conduit, duct seal, water resistant splice connectors, testing, incidental material, equipment, and labor.

<u>Pay Item</u>	<u>Pay Unit</u>
Loop Vehicle Detector	ea. (ea.)
Loop Detector Sawcut	l.f. (m)

S:\traffic\1406\SIGNAL SPECS\SPECS\1111451A-LOOP DETECTOR SAWCUT, rev3-08, polyester compound

ITEM #1111470A - TIME CLOCK

DESCRIPTION:

This item shall consist of furnishing and installing a Time Clock/Time Base Coordination (TC/TBC) unit within a traffic signal cabinet in conformity with these specifications.

MATERIALS:

The four circuit TC/TBC shall conform to the current requirements of the Department of Transportation Functional Specifications for Traffic Control Equipment, Four Circuit Solid State Time Clock With Time Base Coordination Option TC/TBC.

CONSTRUCTION METHODS:

The TC/TBC harness shall be connected into the controller cabinet wiring in a neat and orderly manner. Refer to the TC/TBC INSTALLATION REQUIREMENTS included in the special provisions to Item #1108115A - Full Actuated Controller 8 Phase. All connections shall be to terminals. Splices will not be allowed. The TC/TBC hookup complete with pin number, function and cabinet terminal number shall be recorded in the form of a hookup chart, on 216 mm x 280 mm (8.5"x11") paper. The location, location number, date of revision, project number, TC/TBC manufacturer and model number shall also be recorded on the hookup chart. A program card shall be completed indicating all input steps and settings. Four copies of the hookup chart and program card shall be furnished to the Engineer with one each left in the cabinet. Revise controller timings as shown on the plan.

METHOD OF MEASUREMENT:

This work will be measured for payment by the number of Time Clock/Time Base Coordinators installed; operating in a time base system as designed, and accepted.

BASIS OF PAYMENT:

This work shall be paid for at the contract price each for "Time Clock" which price shall include all materials, labor, tools, 4 copies each of the hookup chart and program card, controller timing changes, and all work incidental thereto.

S:\traffic\1406\signal specs\specs\111470A-time clock.doc

ITEM #1113398A - CABLE CLOSURE (TYPE A)

Work under this item shall conform to the requirements of section 11.13 supplemented and amended as follows:

Article M.16.14 - Control Cable:

Subarticle M.16.14 - 5 - Cable Closure: After the only paragraph add the following: The cable closure installed on the figure 8 cable and used to terminate interconnect shall be designated as Type A. This closure shall be weather resistant, contain an inner shield bond and grounding continuity system. All external parts shall be stainless steel. The closure shall be provided with 3 or 4 entrances, dependent on the number of cables terminated in the closure. The main entrance shall accommodate cable with a diameter of 0.4"(10mm) to 1.0"(25mm) and the branch entrance shall accommodate a cable with a diameter of 0.4"(10mm) to 1.0"(25mm). The size of the closure shall be: length 17" (425mm) to 24" (610mm), width 3" (76mm) to 5" (127mm), height 5" (127mm) to 6.5" (165mm). Each closure shall be provided with a minimum of 24 terminals, either screw type or pressure type.

Article 11.13.03 - Construction Methods:

Subarticle 11.13.03 - 3 Cable Closures: After the only paragraph add the following: The Type A cable closures attached to the figure 8 cable shall be used for to provide an access for the 16/6 pair interconnect to the controller cabinet. The locations shall be as listed below and as shown on the plans.

<u>Intersection</u>	<u>Location No.</u>	<u>Pole No.</u>
U.S. Route. 1 @ Madison Avenue	015-215	U.I. # 10125

Only the conductors designated as "Traffic Signal Interconnect Pairs" in the special provisions to the Communication Cable, shall be cut and terminated in these closures. Connection to traffic signal pairs shall be as shown in the Typical Cable Closure Illustration contained herein. The conductors designated as not used shall not be cut at these closures. The Type A Cable Closures shall be installed approximately 3 feet (0.9 m) from the indicated utility pole, unless otherwise directed by the Engineer.

S:\traffic\1406\signal specs\specs\1113398A-cable closure (type A).doc

ITEM #1113431A - #16 AWG, 6 TWISTED PAIR, COMMUNICATION CABLE

Article M.16.14 - Control Cable

3 - Cable Add the following:

The communication cable shall be solid conductor, shielded, twisted pair with 300 V polyethylene insulation and polyethylene jacket. The 6 Pair Overhead cable shall be figure 8 type with 6650 lb. test, integral messenger and shall conform in all respects to IMSA Specification 40-4. The 6 Pair cable shall conform in all respects to IMSA Specification 40-2. The Contractor shall furnish a manufacturers warranty that the cable is resistant to damage and deterioration by sustained contact with greases and oil.

Article 11.13.03 - Construction Methods Add the following:

Communication cable shall be installed in new and existing conduit, handholes, attached to utility poles or supported on messenger as shown on the plans or as directed by the Engineer. Communication cable shall be installed continuously without splices from termination point to termination point. Cable termination shall be only on an approved termination panel inside the controller cabinet and on terminal blocks inside a cable closure (type A). All cable pairs that enter a controller cabinet and the cable closure shall be terminated as shown on the typical installation plan The pair numbers and colors for traffic signal interconnect are shown on the plans.

The pair overhead cable shall be attached to utility poles indicated on the plans in accordance with the Communications Cable Attachment List. It shall be the Contractors responsibility to coordinate his activities on a continuing basis with each of the involved utility companies. A minimum of 305mm (12") clearance shall be maintained above the highest existing communication cable (SNET or CATV). A minimum of 1016mm (40") clearance shall be maintained below the lowest power cable (Northeast Utilities or United Illuminating) attachment.

The sag shall match that of the next lower communication cable. In no case shall the figure 8 communication cable be allowed to sag into or near existing cables. A Chicago Grip No.1659 or equivalent shall be used to grip the jacketed messenger when pulling and tensioning the figure 8 cable. At corners and ends, the strand shall be dead-ended with strandvises. At corners, the strand shall be cut and the polyethylene jacket removed from the strand. The ends of the strand coming through the chuck of both strandvises shall be overlapped and bonded together using a bolt guy clamp (J1061) or equivalent. At cable closure locations the strand shall be cut and the jacket removed from a sufficient length of strand. A strand vise shall be installed to reattach the strands. This will provide slack in the conductors to properly connect to the terminal blocks without the use of jumpers.

At closures where there is a full cable cut but no branch circuit, bond all the cable shields together.

At branch circuit closures bond the shields of all cables that enter cable closures and ground the shield in the cabinet as shown on the typical installation plan.

Where the support strand will be connected to a vertical grounding conductor and there is no closure near the pole, only the jacket of the strand shall be removed. The jacket around the shield shall not be cut. At the end of each workday notify the electric company to complete the connection to the vertical ground.

Provisions shall be made such that in the event of a cabinet knockdown, wherein accidental overvoltage conditions could be produced in the interconnect cable, the location experiencing the problem will be isolated. No other location shall be damaged. In addition, protective devices shall be furnished and installed by the Contractor to positively isolate and protect the system against damage from lightning.

Article 11.13.04 - Method of Measurement: Add the following:

3. The quantity of communication cable to be paid for under these items shall be the actual number of meters (linear feet) of the cable specified, installed, tested, terminated at the points specified, and accepted in place.

Article 11.13.05 - Basis of Payment: Add the following:

3. Communication Cable shall be paid for at the contract unit price per meter (linear foot) for "#16 AWG, (Type), Communication Cable " which price shall include furnishing, installing, connecting and testing the communication cable of the type specified. The price shall also include standoff brackets; grounding and bonding hardware; overvoltage and lightning protection; furnishing all labor, tools, materials, equipment, storage, transportation and other incidentals necessary to complete the work.

<u>Pay Item</u>	<u>Pay Unit</u>
#16 AWG, (Type), Communication Cable	M. (L.F.)

ITEM #1114201A - AUXILIARY EQUIPMENT CABINET

Description:

Furnish and install an Auxiliary Equipment Cabinet (AEC), on a traffic control cabinet at the location shown on the plans and in accordance with the conditions set forth.

Materials:

- Conform to NEMA 3R enclosure specifications
- Type 5052-H32, 3.175mm (0.125") sheet aluminum
- Finish painted in accordance with the current D.O.T. specifications of Traffic Control Cabinets
- Seams continuously welded and ground smooth
- Dimensions as shown on D.O.T. typical sheets
- Door secured with Corbin lock - Ct. # 2.
- Continuous door hinge, 2.4mm (0.093") thick aluminum with 0.64mm (0.025") stainless steel hinge pin
- Door sealed with oil resistant gasket
- Back panel approximately 330mmH X 229mmW (13"H X 9"W)
- Rust and corrosion resistant mounting hardware
- Screened Vent

Construction Methods:

Mount the AEC on the left side of the controller cabinet, when facing the door. Confirm that the inside of the cabinet wall is clear, so that the installation of the AEC will not damage any equipment inside the controller cabinet. Drill a 25mm (1") hole in the back of the AEC and through the side of the controller cabinet. Install a close nipple through the 25mm (1") hole. Apply clear silicon caulk to both ends of the close nipple. Tighten lock-nuts and fiber bushings. Apply additional caulk if necessary to prevent moisture from entering controller cabinet and auxiliary equipment cabinet.

Method of Measurement:

This item shall be measured for payment by the actual number of Auxiliary Equipment Cabinets installed and accepted on traffic control cabinets.

Basis of Payment:

This item shall be paid for at the contract unit price each for "Auxiliary Equipment Cabinet" which price shall include mounting hardware, close nipple, insulated bushings, tools, and incidentals.

ITEM #1118012A - REMOVAL AND/OR RELOCATION OF TRAFFIC SIGNAL EQUIPMENT

Section 11.18: Replace the entire section with the following:

11.18.01 – Description:

Remove all abandon traffic signal equipment. Restore the affected area. Where indicated on the plans remove and reinstall existing traffic signal equipment to the location shown.

11.18.02 – Materials:

The related sections of the following specifications apply to all incidental and additional material required for the proper relocation of existing equipment and the restoration of any area affected by this work.

- Division III, “Materials Section” of the Standard Specifications.
- Current Supplemental Specifications to the Standard Specifications.
- Current Special Provisions to the Standard Specifications.
- Current Department of Transportation, Functional Specifications for Traffic Control Equipment.

Article 11.18.03 - Construction Methods:

Schedule/coordinate the removal and/or relocation of existing traffic signal equipment with the installation of new equipment to maintain uninterrupted traffic signal control. This includes but is not limited to vehicle signals and detectors, pedestrian signals and pushbuttons, co-ordination, and pre-emption.

Abandoned Equipment

The contract traffic signal plan usually does not show existing equipment that will be abandoned. Consult the existing traffic signal plan for the location of abandoned material especially messenger strand, conduit risers, and handholes that are a distance from the intersection. A copy of the existing plan is usually in the existing controller cabinet. If not, a plan is available from the Division of Traffic Engineering upon request.

Unless shown on the plans it is not necessary to remove abandoned conduit in-trench and conduit under-roadway

When a traffic signal support strand, rigid metal conduit, down guy, or other traffic signal equipment is attached to a utility pole, secure from the pole custodian permission to work on the pole. All applicable DPUC regulations and utility company requirements govern. Keep utility

company apprised of the schedule and the nature of the work. Remove all abandoned hardware, conduit risers, and down guys, Remove anchor rods, to 6” (0.15m) below grade.

When underground material is removed, backfill the excavation with clean fill material. Compact the fill to eliminate settling. Remove entirely the following material: pedestal foundation; controller foundation; handhole; pressure sensitive vehicle detector complete with concrete base. Unless otherwise shown on the plan, remove steel pole and mast arm foundation to a depth of 2 feet (0.6m) below grade. Restore the excavated area to a grade and condition compatible with the surrounding area.

- If in an unpaved area apply topsoil and establish turf in accordance with Section 9.44 and Section 9.50 of the Standard Specifications.
- If in pavement or sidewalk, restore the excavated area in compliance with the applicable Sections of Division II, “Construction Details” of the Standard Specifications.

Relocated Equipment

In the presence of the Engineer, verify the condition of all material that will be relocated and reused at the site. Carefully remove all material, fittings, and attachments in a manner to safeguard parts from damage or loss. Replace at no additional cost, all material which becomes damaged or lost during removal, storage, or reinstallation.

Scrap and Salvage Equipment

Scrap Material	Stock No.
Steel Span Pole, 30’ (9000mm)	330-16-7050
Steel Span Pole, all other lengths	330-16-7016
Steel Mast Arm Assembly	N/A
Copper Cable	N/A
Pedestrian Pushbutton and Sign	N/A

Salvage Material	Stock No.	Value
Controller Cabinet, Complete including but not limited to the following: Conflict Monitor Coordination Equipment Vehicle Detection Equipment	330-03-7010	\$ 500.00
Controller Unit	330-03-7005	\$ 500.00
Aluminum Pedestal 8 foot (2400 mm)	330-16-7108	\$ 100.00
4 foot, 4 inch (1300 mm)	330-16-7112	\$ 100.00

All material not listed as scrap or salvage, becomes the property of the Contractor. Properly handle, transport, then dispose in a suitable dump or recycle this material. Comply with all Federal and State hazardous waste laws and regulations.

In the presence of the Engineer, verify the condition and quantity of salvage material prior to removal. After removal transport and store the material protected from moisture, dirt, and other damage. Coil and secure copper cable separate from other cable such as galvanized support strand.

Within 4 working days of removal, return the State owned scrap and salvage material to the Department of Transportation Stores warehouse listed below. Supply all necessary manpower and equipment to load, transport, and unload the material. The condition and quantity of the material after unloading will be verified by the Engineer.

DOT Salvage Store #134
660 Brook Street
Rocky Hill, CT

Contact Materials Management Scrap and Salvage Coordinator, at (860) 258-1980, at least 24 hours prior to delivery.

Municipal Owned Traffic Signal

Return all municipal owned material such as pre-emption equipment to the Town.

Article 11.18.04 – Method of Measurement:

This work will be measured as a Lump Sum.

Article 11.18.05 – Basis of Payment:

Payment is at the contract lump sum price for “Removal and/or Relocation of Traffic Signal Equipment” inclusive of all labor, vehicle usage, storage, and incidental material necessary for the complete removal of abandoned material and/or relocation of existing traffic signal material. Payment will also include the necessary labor, equipment, and material for the complete restoration of all affected areas.

A credit will be calculated and deducted from monies due the Contractor equal to the listed value of salvage material not returned or that has been damaged and deemed unsalvageable due to the Contractors operations.

Pay Item	Pay Unit
Removal and/or Relocation of Traffic Signal Equipment	l.s (l.s.)

s:\traffic1406\signal specs\specs\1118012A-REMO & RELO T S EQUIP, 4-08

ITEM #1118051A – TEMPORARY SIGNALIZATION (SITE NO. 1)

ITEM #1118052A – TEMPORARY SIGNALIZATION (SITE NO. 2)

ITEM #1118053A – TEMPORARY SIGNALIZATION (SITE NO. 3)

ITEM #1118054A – TEMPORARY SIGNALIZATION (SITE NO. 4)

ITEM #1118055A – TEMPORARY SIGNALIZATION (SITE NO. 5)

ITEM #1118056A – TEMPORARY SIGNALIZATION (SITE NO. 6)

ITEM #1118057A – TEMPORARY SIGNALIZATION (SITE NO. 7)

ITEM #1118058A – TEMPORARY SIGNALIZATION (SITE NO. 8)

ITEM #1118059A – TEMPORARY SIGNALIZATION (SITE NO. 9)

ITEM #1118060A – TEMPORARY SIGNALIZATION (SITE NO. 10)

ITEM #1118071A – TEMPORARY SIGNALIZATION (SITE NO. 11)

ITEM #1118072A – TEMPORARY SIGNALIZATION (SITE NO. 12)

ITEM #1118073A – TEMPORARY SIGNALIZATION (SITE NO. 13)

ITEM #1118074A – TEMPORARY SIGNALIZATION (SITE NO. 14)

ITEM #1118075A – TEMPORARY SIGNALIZATION (SITE NO. 15)

Description:

The Contractor shall keep each traffic signal in the project limits operational at all times during construction through the use of the existing signal, the temporary signal, the revised signal or any combination thereof. The Contractor shall furnish, install, maintain, relocate, and

remove existing, temporary, and proposed traffic signal equipment and all necessary hardware as needed throughout the duration of construction and in conformance with the applicable specifications.

The Contractor shall relocate the existing and temporary traffic signal heads and appurtenances (span poles, mast arms, span wire, pedestrian push buttons, pedestrian walk signals, etc.) and revise the signal phasing and timing as many times as deemed necessary during construction to maintain and protect traffic and pedestrian movements where shown on the plans or as proposed by the Contractor and approved by the Engineer.

The Contractor shall make modifications to the controller as necessary to maintain temporary signalization during each phase/stage of construction.

Throughout the duration of construction, the Contractor shall provide detection on the existing, temporary, and/or new roadway alignment for all intersection approaches that have existing detection. The Contractor shall furnish, install, maintain, relocate and revise the necessary equipment (loop detectors, preformed loop detectors, microwave detectors, cable, conduit, amplifiers, pushbuttons, handholes, etc.) to provide proper vehicle detection and pedestrian detection during each phase of construction. During construction, if a detector becomes non-operational, the associated phase shall be put on max recall and the Contractor shall provide detection within 24 hours.

Throughout the duration of construction, the Contractor shall furnish, install, maintain, relocate, and remove the equipment necessary to maintain existing emergency vehicle pre-emption and the equipment necessary to maintain existing interconnect to adjacent signals.

The Contractor shall furnish, install, maintain, relocate, and remove signal-related signing (lane-use, signal ahead, NTOR, etc.) and pavement markings as needed throughout the duration of construction.

Materials:

All materials used for Temporary Signalization shall conform to the pertinent articles of the Standard Specifications, the Supplemental Specifications, and the Special Provisions contained in this contract, or as approved by the Engineer.

Construction Methods:

In the presence of the Engineer and a representative from the DOT Electrical Maintenance Office, the Electrical Contractor shall inspect the existing controller and verify its working condition prior to Temporary Signalization.

The Contractor shall submit a traffic signal plan to the Engineer for approval showing the signal phasing, timing, and the location of the signal supports, signal heads, detectors, pedestrian push buttons, pedestrian signals, and pavement markings at least 30 days prior to each phase/stage change.

Temporary Signalization will begin when the Contractor revises or relocates the existing signal or installs temporary traffic signal equipment. The Contractor shall be responsible for maintenance of all equipment during Temporary Signalization. The Engineer shall record the date Temporary Signalization begins for each site and shall notify the DOT Electrical Maintenance Office and the Local Police Department that maintenance responsibility has been transferred to the Contractor.

The Contractor shall provide to the Engineer a list of telephone numbers of personnel who will be responsible for the maintenance of the traffic signals during Temporary Signalization. The Contractor shall respond to traffic signal malfunctions by having a representative at the site within three hours and the Contractor shall have the traffic signal back in operation within 24 hours.

If the Engineer determines that the nature of a malfunction requires immediate attention and the Contractor does not respond within three hours following the initial contact, then DOT personnel will be called to repair the signal. The State will deduct all expenses incurred by the State, with a minimum deduction of \$1,000. for each service call, from money due or to due to the contractor.

For intersections with a State furnished controller, Temporary Signalization shall terminate when the signal inspection is complete and is accepted by the Engineer. For intersections with a Contractor furnished controller, Temporary Signalization shall terminate at the beginning of the 30 day test period. For locations that will not be permanently signalized, Temporary Signalization shall terminate when construction is complete and the temporary signal equipment is removed from the project as approved by the Engineer.

All equipment shall be relocated and/or removed in such a manner as to cause no hazard to pedestrians, traffic or property. When the Contractor is performing signal work, the Contractor shall maintain traffic as specified in the Special Provisions "Prosecution and Progress" and "Maintenance and Protection of Traffic."

During Temporary Signalization, all existing equipment shall remain the property of the owner. Temporary equipment supplied by the Contractor for Temporary Signalization will remain the Contractor's property unless noted otherwise. All existing equipment that is removed and designated as salvage shall be returned to the owner.

The Contractor shall be responsible for obtaining secondary service required for continuous operation of the traffic signals during Temporary Signalization. The party previously

ITEM #1118051A, 1118052A, 1118053A,
1118054A, 1118055A, 1118056A,
1118057A, 1118058A, 1118059A,
1118060A, 1118071A, 1118072A,
1118073A, 1118074A, 1118075A

responsible for payment of electricity shall continue to be responsible during Temporary Signalization.

The Contractor shall be responsible for the cost of electricity at unsignalized intersections that require Temporary Signalization due to construction activities. Locations where the temporary signal equipment will be removed when no longer needed shall have a metered service.

Method of Measurement:

Temporary Signalization shall be paid for only once per site on a percentage of the contract Lump Sum price. Fifty percent (50%) shall be paid when Temporary Signalization begins and fifty percent (50%) shall be paid when Temporary Signalization terminates.

Basis of Payment:

This work shall be paid at the contract Lump Sum price for “Temporary Signalization (Site No.)” for each site. This item shall consist of furnishing, installing, maintaining, relocating, revising, and removing existing, temporary, and proposed traffic signal equipment (except for the items identified below), signing and all necessary hardware, materials, labor and work incidental thereto. This price shall also include any modifications to the controller including timing and phasing changes. All Contractor supplied items that will remain the Contractor’s property shall be included in the contract Lump Sum price for “Temporary Signalization.” Any items installed as part of the permanent installation will not be paid for under this item. The following established contract items, if used for Temporary Signalization, will be paid for at the contract unit price: Loop Detector Amplifiers, Trenching and Backfilling, Handholes, Rigid Metal Conduit (Type), Loop Detector Sawcut, Cable, Removal of Pavement Markings, and temporary pavement marking items.

<u>Pay Item</u>	<u>Pay Unit</u>
Temporary Signalization (Site No.)	L.S.

ITEM #1118301A - RELOCATE PRE-EMPTION SYSTEM (SITE NO. 1)

ITEM #1118304A - RELOCATE PRE-EMPTION SYSTEM (SITE NO. 4)

ITEM #1118305A - RELOCATE PRE-EMPTION SYSTEM (SITE NO. 5)

ITEM #1118307A - RELOCATE PRE-EMPTION SYSTEM (SITE NO. 7)

ITEM #1118308A - RELOCATE PRE-EMPTION SYSTEM (SITE NO. 8)

ITEM #1118309A - RELOCATE PRE-EMPTION SYSTEM (SITE NO. 9)

ITEM #1118310A - RELOCATE PRE-EMPTION SYSTEM (SITE NO. 10)

ITEM #1118313A - RELOCATE PRE-EMPTION SYSTEM (SITE NO. 13)

ITEM #1118314A - RELOCATE PRE-EMPTION SYSTEM (SITE NO. 14)

Description:

Relocate existing town owned emergency vehicle pre-emption system (EVPS) (either optical or siren) as shown on the plan or as directed by the Engineer. The EVPS equipment includes but is not limited to the following material:

- Optical Detectors
- Siren Detectors
- Phase Selectors
- System Chassis
- Auxiliary Equipment Cabinets (AEC)
- Confirmation Light
- Detector Cable (where practical)

Install new cable from the controller to the pre-emption detectors where the existing cable cannot be practically relocated.

Material:

All material is existing except for miscellaneous hardware necessary for reinstallation (e.g. changing detector attachment from span wire to mast arm) and the Detector Cable.

Miscellaneous Hardware:

1. Mounting hardware designed and manufactured specifically for use with the existing EVPS.
2. Corrosion and rust resistant.

Detector Cable (Optical):

1. 3-Conductor cable with shield and ground wire.
2. AWG #20 (7x28) stranded.
3. Individually tinned copper strands.

4. Conductor insulation: 600 volt, 167^o F (75 deg. C).
5. 1 Conductor-yellow; 1 Conductor-blue; 1 Conductor-orange.
6. Aluminized mylar shield tape or equivalent.
7. AWG #20 (7x28) stranded uninsulated drain wire
8. DC resistance not to exceed 11.0 ohms per 1000 feet (305M).
9. Capacitance from one conductor to other two conductors and shield not to exceed 157pf/M (48 pf./ft.).
10. Jacket: 600 volts, 176^o F (80 deg. C), minimum average wall thickness - 0.045" (1.14mm).
11. Finished O.D.: 0.3" (7.62mm) max.

Detector Cable (Audio):

1. 2-Conductor cable with shield and ground wire.
2. AWG #14.
3. IMSA Spec 50-2 Detector Lead-In.

Construction Methods:

Conduct an initial evaluation test before removal and a final test after reinstallation. Thirty days prior to disconnection and removal of the existing pre-emption equipment, test and verify that the system is operational as shown on the plan. The thirty days is intended to provide the EVPS owner an opportunity to correct and resolve any deficiencies identified during the test. If during the thirty days the owner repairs, replaces, or corrects any malfunctioning, disconnected, or missing components, re-test that feature prior to removal. The contractor is not responsible to correct any part of the EVPS that is found to be malfunctioning, disconnected, or missing during the initial test. If the contractor is to assume maintenance responsibility of the traffic signal during Temporary Signalization, the EVPS equipment will not be included. Maintenance responsibility remains with the owner.

EVPS Test Procedure

1. Notify the system owner/user, such as the municipal fire chief or public works director, of the scheduled inspection.
2. Request a fire department representative and an emergency vehicle, which has an activation device to conduct the test. If not available, the contractor shall provide an activation device.
3. In the presence of the Engineer and the municipal representative, test each pre-empted approach with the emergency vehicle. Test the following items of the system:
 - * Confirm that the emitter or siren activates the phase selector and the phase selector activates the correct pre-emption input to the controller.
 - * Confirm adequate range. The traffic signal must be pre-empted to green sufficiently in advance of the emergency vehicle arrival. The vehicle emitter or siren shall initiate pre-emption at a minimum distance of 548.6M (1800 feet).
Exception: An obstructed line-of-sight may reduce the minimum distance. Town concurrence is required.
 - * Confirm there are no false calls. Keep the emitter or siren active as the emergency vehicle passes through the intersection. No other detectors shall activate.
4. Document the test. Provide the Engineer and the municipality copies of the test results. Attached is a sample test procedure form.

Keep the appropriate fire department official apprised of when (day and time) the system is disconnected and taken out of operation.

Store all pre-emption equipment intended for re-installation in a suitable location to prevent damage from elements and construction activities. Return all pre-emption equipment not intended for re-installation to the Town.

Mount the AEC on the left side of the controller cabinet, when facing the door. Confirm that the inside of the cabinet wall is clear, so that the installation of the AEC will not damage any equipment inside the controller cabinet. Drill a 25mm (1") hole through the side of the controller cabinet. Install a close nipple through the 25mm (1") hole. Apply clear silicon caulk to both ends of the close nipple. Tighten lock-nuts and fiber bushings. Apply additional caulk if necessary to prevent moisture from entering the controller cabinet and the AEC.

Re-install and wire the pre-emption equipment in a neat and orderly manner, as shown on the plan or as directed by the Engineer. Pre-emption detector locations shown on the plan are for illustration purposes only. Field locate the detectors for the best possible line-of-sight. Install the detector cables continuous with no splices between the optical detector and the AEC. Make all connections from the phase selector to the "D" harness and to the cabinet wiring at the pre-emption termination panel.

Conduct a final test, identical to the initial test, to verify that the EVPS is as operational as before removal. If the initial test was not conducted, it is assumed the EVPS was fully operational as shown on the plan. The Contractor is then responsible for all damaged; faulty; missing; and replacement material necessary to restore the EVPS to fully operational.

If a malfunction is found other than identified during the initial test, or the system needs adjustment (such as range, emitter intensity, or detector location), schedule a follow-up test. Repeat the test procedure for all approaches that did not pass.

Notify the appropriate fire department official that the EVPS has been re-installed and is operational.

If not present in an existing traffic controller cabinet install a pre-emption disconnect switch. When switched off, the traffic controller shall not be affected by EVPS calls.

Method of Measurement:

Work under this item is measured as Lump-Sum per site. Detector Cable shall be measured by the number of linear feet (meters) supplied and installed.

Basis of Payment:

This work shall be paid at the contract Lump Sum price for "Relocate Pre-Emption System (Site No.)" for each site. This item shall include all prior testing, removal, storage, re-installation, final testing, any corrective adjustments, replacement components if necessary, documentation, disconnect switch if necessary, and all necessary hardware, materials, labor and work incidental thereto.

<u>Pay Item</u>	<u>Pay Unit</u>
Relocate Pre-emption System (Site No._)	L.S.

EVPS TEST PROCEDURE

Confirm that the emitter or siren activates the phase selector and the phase selector activates the correct pre-emption input to the controller.	
Confirm adequate range.	
Confirm there are no false calls.	

ITEM # 1118301A, 1118304A, 1118305A
1118307A, 1118308A, 1118309A, 1118310A,
1118313A, 1118314A

ITEM #1206013A - REMOVAL OF EXISTING SIGNING

Section 12.06 is supplemented as follows:

Article 12.06.03 – Construction Methods is supplemented as follows:

Sheet aluminum signs designated for removal are to be salvaged if they are in suitable condition as determined by the Engineer. The Contractor shall sort all salvaged sheet aluminum signs by size and shall stack ten signs to a bundle. Each bundle shall be bound by tape or metal strap and the bundles shall be stacked on pallets. The Contractor shall confirm intended delivery of the salvaged sheet aluminum signs at least seven days in advance and shall deliver the signs to the following address:

D.O.T. Sign Shop
1107 Cromwell Avenue
Rocky Hill, CT 06067
Attention: Jeffrey Adams (Phone # 860-258-4675)

Signs not suitable for salvage and sign supports designated for removal shall be removed and disposed of by the Contractor as directed by the Engineer and in accordance with existing standards for removal of signing.

ITEM #1220011A - CONSTRUCTION SIGNS – TYPE III REFLECTIVE SHEETING

Article 12.20.01 – Description: The Contractor shall furnish construction signs with Type III reflective sheeting and their required portable supports or metal sign posts that conform to the requirements of NCHRP Report 350 (TL-3) and to the signing requirements stated in Article 9.71 “Maintenance and Protection of Traffic,” as shown on the plans and/or as directed by the Engineer.

Article 12.20.02 – Materials: Prior to using the construction signs and their portable supports, the Contractor shall submit to the Engineer a copy of the Letter of Acceptance issued by the FHWA to the manufacturer documenting that the devices (both sign and portable support tested together) conform to NCHRP Report 350 (TL-3).

Portable sign supports shall be designed and fabricated so that the signs do not blow over or become displaced by the wind from passing vehicles. Portable sign supports shall be approved by the Engineer before they are used.

Mounting height of signs on portable sign supports shall be a minimum of 1 foot and a maximum of 2 feet, measured from the pavement to the bottom of the sign.

All sign faces shall be rigid and reflectorized. Reflective sheeting shall conform to the requirements of Article M.18.09.01 (Type III). Sheet aluminum sign blanks shall conform to the requirements of Article M.18.13. Metal sign posts shall conform to the requirements of Article M.18.14. Application of reflective sheeting, legends, symbols, and borders shall conform to the requirements specified by the reflective sheeting manufacturer. Attachments shall be provided so that the signs can be firmly attached to the portable sign supports or metal posts without causing damage to the signs.

The following types of construction signs shall not be used: mesh, non-rigid, roll-up.

The following portable sign support systems or equivalent systems that meet the above requirements may be used:

- Korman Model #SS548 flexible sign stand with composite aluminum sign substrate (APOLIC)
- Traffix “Little Buster” dual spring folding sign stand with corrugated polyethylene (0.4 in. thick) sign substrate (InteCel)

Article 12.20.03 – Construction Methods: Ineffective signs, as determined by the Engineer and in accordance with the ATSSA guidelines contained in “Quality Standards for Work Zone Traffic Control Devices”, shall be replaced by the Contractor at no cost to the State.

Signs and their portable supports or metal posts that are no longer required shall be removed from the project and shall remain the property of the Contractor.

Article 12.20.04 – Method of Measurement: Construction Signs - Type III Reflective Sheeting will be measured for payment by the number of square feet of sign face. Sign supports will not be measured for payment.

Article 12.20.05 – Basis of Payment: “Construction Signs – Type III Reflective Sheeting” required and used on the project will be paid for at the Contract unit price per square foot. This price shall include the furnishing and maintenance of the signs, portable sign supports, metal sign posts and all hardware. Each sign and support or posts will be paid for once, regardless of the number of times it is used.

Pay Item	Pay Unit
Construction Signs – Type III Reflective Sheeting	S.F.

State of Connecticut

Department of Transportation

SUPPLEMENTAL SPECIFICATIONS

TO

THE STANDARD SPECIFICATIONS

FOR

ROADS, BRIDGES AND INCIDENTAL CONSTRUCTION

FORM 816

2004

JULY 2010

July 2010

DIVISION I
GENERAL REQUIREMENTS AND COVENANTS

<u>SECTION</u>		<u>SPECIFICATION NUMBER</u>
1.01	Definition of Terms and Permissible Abbreviations	101
1.05	Control of the Work	105
1.08	Prosecution and Progress	108
1.09	Measurement and Payment	109
1.10	Environmental Compliance	110
1.11	Claims	111
1.20	General Clauses for Facilities Construction	120

DIVISION II
CONSTRUCTION DETAILS

<u>SECTION</u>		<u>SPECIFICATION NUMBER</u>
2.02	Roadway Excavation, Formation of Embankment and Disposal of Surplus Material	202
2.05	Trench Excavation	205
3.04	Processed Aggregate Base	304
4.01	Concrete Pavement	401
5.14	Prestressed Concrete Members	514
6.01	Concrete for Structures	601
6.03	Structural Steel	603
6.12	Concrete Cylinder Curing Box	612
6.51	Culverts	651
7.02	Piles	702
8.22	Temporary Precast Concrete Barrier Curb	822
9.10	Metal Beam Rail	910
9.18	Three-Cable Guide Railing (I-Beam Post) and Anchorages	918
9.22	Bituminous Concrete Sidewalk	
	Bituminous Concrete Driveway	922
9.44	Topsoil	944
9.49	Furnishing, Planting and Mulching Trees, Shrubs, Vines and Ground Cover Plants	949
9.75	Mobilization	975
10.01	Trenching and Backfilling	1001
10.10	Concrete Handhole	1010
11.13	Control Cable	1113
12.10	Epoxy Resin Pavement Markings, Symbols and Legends	1210

July 2010

DIVISION III
MATERIALS SECTION

SECTION

**SPECIFICATION
NUMBER**

M.06	Metals	M06
M.13	Roadside Development	M13
M.16	Traffic Control Signals	M16
M.17	Elastomeric Materials	M17
M.18	Signing	M18

July 2010
STANDARD SPECIFICATIONS
FOR
ROADS, BRIDGES AND INCIDENTAL CONSTRUCTION
FORM 816

ERRATA

<u>PG.</u>	<u>ARTICLE OR SUBARTICLE</u>	<u>LINE NO.</u>	<u>CORRECTION</u>
iv	Table of Contents	11	Change "Guild" to "Guide"
4	1.01.01	8	After the end of the definition for "Plans," insert as a subset, "A. Standard Sheets – Standardized plans containing details approved by the Department and the FHWA, for construction of a given type on any project, included in contracts on an as-needed basis."
6	1.01.02	41	Change "Aluminum Association" to "Aluminum Association, Inc. (The)"
6	1.01.02	42	Delete "AAA – Aluminum Alloy Association"
7	1.01.02	1	Insert "AABC – Associated Air Balance Council"
7	1.01.02	1	Insert "AAMA – American Architectural Manufacturers Association"
7	1.01.02	12	Insert "ABMA – American Bearing Manufacturers Association"
7	1.01.02	12	Insert "ACGIH – American Council of Government Industrial Hygienists"
7	1.01.02	12	Change "American Concrete Institute" to "ACI International (American Concrete Institute)"
7	1.01.02	14	Insert "ADAAG – Americans with Disabilities Act (ADA) Accessibility Guidelines for Buildings and Facilities"
7	1.01.02	16	Change "Associated General Contractors of America" to "Associated General Contractors of America (The)"
7	1.01.02	19	Insert "AI – Asphalt Institute"
7	1.01.02	19	Change "American Institute of Architects" to "American Institute of Architects (The)"
7	1.01.02	20	Delete "AIEE – American Institute of Electrical Engineers "
7	1.01.02	24	Delete "ALI – Associated Laboratories, Inc."
7	1.01.02	26	Change "American Lumber Standard Committee" to "American Lumber Standards Committee, Incorporated"
7	1.01.02	27	Change "Air Movement and Control Association" to "Air Movement and Control Association International, Inc."
7	1.01.02	31	Delete "AOEC – Area of Environmental Concern"
7	1.01.02	33	Change "The Engineered Wood Association" to "APA-The Engineered Wood Association"
7	1.01.02	37	Change "Air Conditioning" to "Air-Conditioning"
8	1.01.02	7	Change "Air Conditioning" to "Air-Conditioning"
8	1.01.02	8	Change "American Society of Mechanical Engineers" to "ASME International (The American Society of Mechanical Engineers International)"
8	1.01.02	18	Delete "ATA – American Transit Association"
8	1.01.02	20	Delete "AWG – American Wire Gauge"
8	1.01.02	22	Change "Wood-Preservers" to "Wood-Preservers' "
8	1.01.02	33	Delete "AZI – American Zinc Institute"
8	1.01.02	35	Change "Building Officials and Code Administrators International" to "BOCA International, Inc."

<u>PG.</u>	<u>ARTICLE OR SUBARTICLE</u>	<u>LINE NO.</u>	<u>CORRECTION</u>
8	1.01.02	38	Change "Library" to "Laboratory"
9	1.01.02	2	Change "CONNDOT" to "ConnDOT"
9	1.01.02	6	Delete "CPI – Clay Pipe Institute"
9	1.01.02	9	Delete "CS – Commercial Standard"
9	1.01.02	10	Change "Construction Specifications Institute" to "Construction Specifications Institute (The)"
9	1.01.02	12	Change "Tower" to "Technology"
9	1.01.02	17	Delete "DFPA – Douglas Fir Plywood Association"
9	1.01.02	19	Change "Department of Defense" to "Department of Defense Military Specifications and Standards"
9	1.01.02	21	Change "Association" to "Alliance"
9	1.01.02	23	Delete "U.S. Department of Transportation"
9	1.01.02	28	Delete "U.S. Department of Transportation"
9	1.01.02	30	Insert "FMG – FM Global"
9	1.01.02	31	Delete "U.S. Department of Transportation"
10	1.01.02	2	Delete "HASP – Health and Safety Plan"
10	1.01.02	3	Delete "HMA – Hot Mix Asphalt or Bituminous Concrete"
10	1.01.02	4	Delete "HPMA – Hardwood Plywood Manufacturers Association"
10	1.01.02	5	Insert "HPVA – Hardwood Plywood & Veneer Association"
10	1.01.02	9	Insert "ICC – International Code Council"
10	1.01.02	9	Change "Insulated Cable Engineers Association" to "Insulated Cable Engineers Association, Inc."
10	1.01.02	10	Change "Institute of Electrical and Electronics Engineers" to "Institute of Electrical and Electronics Engineers, Inc. (The)"
10	1.01.02	21	Change "Military Standardization Documents, U.S. Department of Defense" to "(MILSPEC) Military Specification and Standards"
10	1.01.02	24	Delete "MS – Military Specifications"
10	1.01.02	26	Change "Manufacturers Standardization Society of the Valve and Fittings Industry Inc." to "Manufacturers Standardization Society of The Valve and Fittings the Valve Industry Inc."
10	1.01.02	29	Change "National Association of Architectural Metal Manufacturers (The)" to "National Association of Architectural Metal Manufacturers"
10	1.01.02	31	Insert "NADCA – National Air Duct Cleaners Association"
10	1.01.02	34	Delete "NBS – National Bureau of Standards"
10	1.01.02	35	Delete "NC – National Course"
11	1.01.02	3	Delete "NCPRC – National Clay Pipe Research Corporation"
11	1.01.02	10	Change "International Electrical Testing Association" to "InterNational Testing Association"
11	1.01.02	12	Delete "NFS – NFS International"
11	1.01.02	13	Insert "NHLA – National Hardwood Lumber Association"
11	1.01.02	18	Insert "NLGA – National Lumber Grades Authority"
11	1.01.02	18	Delete "NLMA – National Lumber Manufacturers Association"
11	1.01.02	21	Insert "NSF – NSF International"
11	1.01.02	21	Change "National Terrazzo and Mosaic Association (The)" to "National Terrazzo and Mosaic Association, Inc."
11	1.01.02	26	Delete "PCC – Portland Cement Concrete"
11	1.01.02	28	Delete "PLP – Plastic Laminate Producers"
11	1.01.02	29	Delete "PS – Product Standard of NBS, U.S. Department of Commerce"
11	1.01.02	32	Delete "RLMI – Reflector and Lamp Manufacturers' Institute"

<u>PG.</u>	<u>ARTICLE OR SUBARTICLE</u>	<u>LINE NO.</u>	<u>CORRECTION</u>
11	1.01.02	35	Delete "SAWP – Society of American Wood Preservers"
11	1.01.02	36	Insert "SDI – Steel Deck Institute"
11	1.01.02	36	Insert "S.D.I. – Steel Door Institute"
11	1.01.02	37	Insert "SJI – Steel Joist Institute"
11	1.01.02	37	Insert "SMACNA – Sheet Metal and Air Conditioning Contractors' National Association"
11	1.01.02	37	Change "Southern Pine Inspection Bureau" to "Southern Pine Inspection Bureau (The)"
12	1.01.02	9	Change "Tile Council of America" to "Tile Council of America, Inc."
12	1.01.02	10	Insert "TIA – Telecommunications Industry Association"
12	1.01.02	10	Insert "TPI – Truss Plate Institute, Inc."
12	1.01.02	10	Delete "UBC – Uniform Building Code"
12	1.01.02	11	Change "Underwriters Laboratories, Inc." to "Underwriters Laboratories Inc."
12	1.01.02	12	Delete "UMTA – Urban Mass Transportation Administration, U.S. Department of Transportation"
12	1.01.02	14	Delete "UPC – Uniform Plumbing Code"
12	1.01.02	15	Insert "USGBC – U.S. Green Building Council"
12	1.01.02	16	Delete "USS – United States Standard"
12	1.01.02	17	Delete "VOC – Volatile Synthetic Organic Chemicals"
12	1.01.02	19	Delete "WCLA – West Coast Lumberman's Association"
12	1.01.02	20	Insert "WCSC – Window Covering Safety Council"
12	1.01.02	20	Delete "WSA – Temporary Waste Stockpile Area"
12	1.01.03	31	Insert "AOEC – Area of Environmental Concern"
12	1.01.03	31	Insert "AWG – American Wire Gauge"
13	1.01.03	16	Insert "HASP – Health and Safety Plan"
13	1.01.03	29	Insert "PCC – Portland Cement Concrete"
14	1.01.03	25	Insert "VOC – Volatile Organic Compound"
14	1.01.03	26	Insert "WSA – Temporary Waste Stockpile Area"
22	1.03.07	23	Change " \$1,000,000 " to " \$2,000,000 "
32	1.05.01	38	Change "Connecticut General Statutes" to "CGS"
45	1.05.15	29	Change "Department of Public Utility Control" to "DPUC"
105	1.20	29	Change "Workmen and Equipment" to "Personnel and Equipment"
105	1.20	31	Delete "Completion of Construction Work and"
107	1.20-1.02.13	15	Change "Americans with Disabilities Act Accessibility Guidelines" to "ADAAG"
108	1.20-1.04.01	26	Change "othewise" to "otherwise"
119	1.20-1.05.25	4	Change "Certificate of Compliance" to "C.O.C."
122	1.20-1.06.08	3	Change "Certificate of Compliance" to "C.O.C."
131	1.20-1.08.05	34	Change "Workmen and Equipment" to "Personnel and Equipment"
132	1.20-1.08.11	12	Change "Certificate of Compliance" to "C.O.C."
133	1.20-1.08.13	7	Delete "Completion of Construction Work and"
133	1.20-1.08.13	9	Change "Certificate of Compliance" to "C.O.C."
133	1.20-1.08.11	15	Change "Certificate of Compliance" to "C.O.C."
133	1.20-1.08.11	20	Change "Certificate of Compliance" to "C.O.C."
143	2.02.01	28	Insert ", swales" after "channels"
245	4.06.04	11	Change " Over weight (mass) Adjustments - " and replace with indented "Over weight (mass) Adjustments -" as a subsection of " 1. Bituminous Concrete Class () ".

<u>PG.</u>	<u>ARTICLE OR SUBARTICLE</u>	<u>LINE NO.</u>	<u>CORRECTION</u>
259	5.03.03	24	Change "Such requirements of Article 5.02.03 as are pertinent shall apply equally to this construction." To "All such plans prepared by the Contractor shall be considered working drawings and shall be submitted with engineering calculations to the Engineer for review in accordance with the requirements of Article 1.05.02."
270	5.08.02	4	Change "M.06.02-12" to "M.06.02-4 Welded Stud Shear Connectors"
271	5.09.02	39	Change "M.06.02-12" to "M.06.02-4 Welded Stud Shear Connectors"
284	5.14.03-12	12	Change "Article M.06.02-13" to "Subarticle 6.03.03 (a) Shop Fabrication Notice"
351	6.03.03	8	Change "MS MIL-C-11796B" to "MIL-C-11796B"
434	9.04.02	14	Change "Subarticle M.06.02-1" to "Article 6.03.02"
434	9.04.02	15	Change "M.06.02-9(d) for metal bridge rail (cast post—aluminum)." to "Malleable castings shall conform to the requirements of the specifications for malleable iron castings, ASTM A 47, Grade No. 32510 (22010). Ductile iron castings shall conform to the Specifications for Ductile Iron Castings, ASTM A 536, Grade 60-40-18 (414-276-18) unless otherwise specified. In addition to the specified test coupons, test specimens from parts integral with the castings, such as risers, shall be tested for castings having a weight (mass) of more than 1000 pounds (455 kilograms) to determine that the required quality is obtained in the castings in the finished condition."
452	9.14.02	2	Change "Subarticle M.06.02-8" to "ASTM A 53, Type E or S, Grade A, Schedule 40 Black Finish."
452	9.14.02	4	Change "Subarticle M.06.02-9(d) except that the grade shall be 32510" to "the specifications for malleable iron castings, ASTM A 47, Grade No. 32510 (22010). Ductile iron castings shall conform to the Specifications for Ductile Iron Castings, ASTM A 536, Grade 60-40-18 (414-276-18) unless otherwise specified. In addition to the specified test coupons, test specimens from parts integral with the castings, such as risers, shall be tested for castings having a weight (mass) of more than 1000 pounds (455 kilograms) to determine that the required quality is obtained in the castings in the finished condition."
496	9.70.01	37	Change "CDOT" to "ConnDOT"
577	12.01.03	7	Change "6.03.03-19" to "6.03.03-4 (f) High Strength Bolted Connections"
577	12.01.03	23	Change "Article 6.03.03-15" to "Subarticle 6.03.03-4(c) Bearings"
577	12.01.03	27	Change "Article 6.03.03-19 (c)(3)" to "Subarticle 6.03.03-4 (f) High Strength Bolted Connections Turn-of-Nut Installation Method"
604	18.00.02	7	Change "National Cooperative Highway Research Program (NCHRP)" to "NCHRP"
623	M.03.01	9	Change "Cement and Concrete Reference Laboratory" to "CCRL"
623	M.03.01	13	Change "Cement and Concrete Reference Laboratory" to "CCRL"
626	M.03.01	2	Change "Cement and Concrete Reference Laboratory" to "CCRL"
626	M.03.01	3	Change "NBS" to "NIST"
632	M.03.01	18	Change "Cement and Concrete Reference Laboratory" to "CCRL"
638	M.04.02	37	Change "Asphalt Institute's" to "AI's"

<u>PG.</u>	<u>ARTICLE OR SUBARTICLE</u>	<u>LINE NO.</u>	<u>CORRECTION</u>
711	M.10.02-1	17	Change "Subarticle M.06.02-1(b)" to "Article M.06.02"
720	M.10.08-3	2	Change "Subarticle M.06.02-1(b)" to "Article M.06.02"
735	M.13.03	22	Change "AOAC International" to "AOAC"
760	M.15.15	21	Change "non-fusible" to "fused"
780	M.16.08	41	Change "Americans With Disabilities Act (ADA)" to "ADA"
790	M.16.10	24	Change "Underwriter's Laboratory" to "UL"
800	M.17.01	19	Change "AAA 6061-T6" to "AA 6061-T6"
845	Index	6	Add page 133 to "Acceptance of Project"
846	Index	13	Add page 107 to "Bids: Consideration of"
847	Index	28	Add page 132 to "Cleaning Up, Final"
849	Index	25	Add page 107 to "Consideration of Bids"
849	Index	39	Add page 108 to "Contract: Intent of"
850	Index	3	Add page 133 to "Contractor's: Responsibility, Termination of the"
850	Index	13	Add page 114 to "Cooperation by Contractor"
850	Index	15	Add page 114 to "Coordination of Special Provisions, Plans, Supplemental Specifications and Standard Specifications and Other Contract Requirements"
850	Index	40	Add page 128 to "Cutting and Patching:"
852	Index	16	Add page 106 to "Examination of Plans, Specifications, Special Provisions and Site of Work"
852	Index	38	Insert "Facilities, Temporary...126"
853	Index	7	Add page 132 to "Final: Cleaning Up"
854	Index	35	Add page 115 to "Inspection"
855	Index	11	Add page 108 to "Intent of Contract"
855	Index	22	Add page 106 to "Knowledge of Applicable Laws"
855	Index	25	Add page 106 to "Laws: Knowledge of Applicable"
856	Index	27	Add page 120 to "Materials: Source of Supply and Quality"
856	Index	28	Add page 121 to "Materials: Storage of"
857	Index	33	Add page 133 to "Operation and Maintenance Manuals:"
857	Index	34	Change page 133 to 136 for "Equipment and Systems Maintenance Manual"
859	Index	2	Add page 131 to "Personnel and Equipment"
860	Index	6	Add page 114 to "Plans: Coordination of Special Provisions, Supplemental Specifications and Standard Specifications and Other Contract Requirements"
860	Index	7	Add page 106 to "Plans: Examination of"
860	Index	30	Change page 108 to 112 for "Product Data"
860	Index	31	Change page 108 to 112 for "Product Samples "
860	Index	32	Add page 124 to "Product Selection:"
861	Index	12	Add page 126 to "Prosecution of Work"
861	Index	38	Change page 115 to 135 for "Record Drawings"
863	Index	3	Add page 125 to "Sanitary Provisions"
863	Index	18	Insert "Services, Temporary...126"
863	Index	23	Add page 111 to "Shop Drawings"
864	Index	4	Add page 106 to "Site of Work, Examination of"
864	Index	12	Add page 120 to "Source of Supply and Quality"
864	Index	19	Add page 114 to "Special Provisions: Coordination of Plans, Supplemental Specifications and Standard Specifications and Other Contract Requirements"
864	Index	20	Add page 106 to "Special Provisions: Examination of"

<u>PG.</u>	<u>ARTICLE OR SUBARTICLE</u>	<u>LINE NO.</u>	<u>CORRECTION</u>
864	Index	26	Add page 114 to "Specifications: Coordination of Plans, Special Provisions and Other Contract Requirements"
864	Index	27	Add page 106 to "Specifications: Examination of"
864	Index	43	Add page 121 to "Storage"
865	Index	27	Delete page 108 from "Submittals: Shop Drawings"
865	Index	45	Insert "Temporary Utilities, Services, and Facilities...126"
866	Index	2	Add page 133 to "Termination of Contractor's Responsibility"
866	Index	23	Insert "Training...137"
866	Index	45	Add page 133 to "Utility Services"
867	Index	8	Insert "Warranties...121"
867	Index	24	Add page 126 to "Work: Prosecution of"

**CONNECTICUT
SUPPLEMENTAL SPECIFICATION
SECTION 1.01
DEFINITIONS OF TERMS AND
PERMISSIBLE ABBREVIATIONS**

1.01.01 — Definitions:

Add the following definition:

SUBSTANTIAL COMPLETION: The date at which the performance of all work on the Project has been completed except minor or incidental items, final cleanup, work required under a warranty, and repair of unacceptable work, and provided the Engineer has determined that:

- A. The Project is safe and convenient for use by the public, and
- B. All traffic lanes including all safety appurtenances are in their final configuration, and
- C. Failure to complete the work and repairs excepted above does not result in the deterioration of other completed work; and provided further, that the value of work remaining to be performed, repairs, and cleanup is less than one percent (1%) of the estimated final Contract amount, and
- D. If applicable a Certificate of Compliance has been issued.

1.01.02 — Abbreviations, Publications, and Standards:

Delete the like-named abbreviations and replace it with the following abbreviations:

“**AA** – Aluminum Association, Inc. (The)
ALSC – American Lumber Standard Committee, Incorporated
AMCA – Air Movement and Control Association International, Inc.
AOSA – Association of Official Seed Analysts, Inc.
ASME – ASME International (The American Society of Mechanical Engineers International)
CTI – Cooling Technology Institute
EIA – Electronic Industries Alliance
ICEA – Insulated Cable Engineers Association, Inc.
IEEE – Institute of Electrical and Electronics Engineers, Inc. (The)
NTMA – National Terrazzo & Mosaic Association, Inc. (The)
TCA – Tile Council of America, Inc.”

Delete the Following abbreviations:

“**ADA** – Americans with Disabilities Act
AFPA – American Forest and Paper Association

BOCA – Building Officials and Code Administrators International
FM – Factory Mutual System
ICBO – International Conference of Building Officials
MIL – Military Standardization Documents, U.S Department of Defense
MS – Military Specifications
NWWDA – National Wood Window and Door Association
NFS – NFS International”

Add the following abbreviations:

“**ADAAG** – Americans with Disabilities Act (ADA)
AABC – Associated Air Balance Council
AAMA – American Architectural Manufacturers Association
ABMA – American Bearing Manufacturers Association
AF&PA – American Forest & Paper Association
AI – Asphalt Institute
BIA – Brick Industry Association (The)
CDA – Copper Development Association Inc.
CGA – Compressed Gas Association
FMG – FM Global
HI – Hydraulic Institute
HPVA – Hardwood Plywood & Veneer Association
ICC – International Code Council
ICC-ES – ICC Evaluation Service, Inc.
IEC – International Electrotechnical Commission
IGMA – Insulating Glass Manufacturers Alliance
ISO – International Organization for Standardization
MILSPEC – Military Specification and Standards
NADCA – National Air Duct Cleaners Association
NFRC – National Fenestration Rating Council
NHLA – National Hardwood Lumber Association
NSF – NSF International (National Sanitation Foundation International)
PDI – Plumbing & Drainage Institute
SDI – Steel Deck Institute *or*
- Steel Door Institute
SJI – Steel Joist Institute
SMACNA – Sheet Metal and Air Conditioning Contractors’ National Association
SPRI – Single Ply Roofing Industry
SWRI – Sealant, Waterproofing, & Restoration Institute
TIA/EIA – Telecommunications Industry Association/Electronic Industries Alliance
TRB – Transportation Research Board
UFAS – Uniform Federal Accessibility Standards
USGBC – U.S. Green Building Council
WDMA – Window & Door Manufacturers Association”

**CONNECTICUT
SUPPLEMENTAL SPECIFICATION
SECTION 1.05
CONTROL OF THE WORK**

Replace Article 1.05.08 – Vacant with the following:

1.05.08—SCHEDULES AND REPORTS:

When a project coordinator is not required by the Contract the following shall apply:

Baseline Bar Chart Construction Schedule: Within 20 calendar days after contract award the Contractor shall develop a comprehensive bar chart as a baseline schedule for the project. The bar chart schedule shall be submitted to the Engineer for approval and shall be based on the following guidelines:

1. The bar chart schedule shall contain a list of activities that represents the major activities of the project. At a minimum, this list should include a breakdown by individual structure or stage, including major components of each. The bar chart schedule shall contain sufficient detail to describe the progression of the work in a comprehensive manner. As a guide, 10 to 15 bar chart activities should be provided for each \$1 million of contract value. The following list is provided as an example only and is not meant to be all-inclusive or all-applicable:

General Activities Applicable to all projects

Project Constraints

- Winter shutdowns
- Environmental permits/application time of year restrictions
- Milestones
- Third Party approvals
- Long lead time items (procurement and fabrication of major elements)
- Adjacent Projects or work by others

Award

Notice to Proceed

Signing (Construction, temporary, permanent by location)

Mobilization

Permits as required

Field Office

Utility Relocations

Submittals/shop drawings/working drawings/product data

Construction of Waste Stock pile area

Clearing and Grubbing

Earthwork (Borrow, earth ex, rock ex etc.)

Traffic control items (including illumination and signalization)

Pavement markings

Roadway Construction (Breakdown into components)

Drainage (Breakdown into components)

Culverts
Plantings (including turf establishment)
Semi-final inspection
Final Cleanup

As required the following may supplement the activities listed above for the specific project types indicated:

a. For bridges and other structures, include major components such as abutments, wingwalls, piers, decks and retaining walls; further breakdown by footings, wall sections, parapets etc.

Temporary Earth Retention Systems
Cofferdam and Dewatering
Structure Excavation
Piles/test piles
Temporary Structures
Removal of Superstructure
Bearing Pads
Structural Steel (Breakdown by fabrication, delivery, installation, painting etc.)
Bridge deck

b. Multiple location projects such as traffic signal, incident management, lighting, planting and guiderail projects will be broken down first by location and then by operation. Other major activities of these types of projects should include, but are not limited to:

Installation of anchors
Driving posts
Foundations
Trenching and Backfilling
Installation of Span poles/mast arms
Installation of luminaries
Installation of cameras
Installation of VMS
Hanging heads
Sawcut loops
Energizing equipment

c. Facility Projects – Facilities construction shall reflect the same breakdown of the project as the schedule of values:

Division 2 – Existing Conditions
Division 3 – Concrete
Division 4 – Masonry
Division 5 – Metals

Division 6 – Wood, Plastic, and Composites
Division 7 – Thermal and Moisture Protection
Division 8 – Openings
Division 9 – Finishes
Division 10 – Specialties
Division 11 – Equipment
Division 12 - Furnishings
Division 13 – Special Construction
Division 14 – Conveying Equipment
Division 21 – Fire Suppression
Division 22 – Plumbing
Division 23 – Heating, Ventilating, and Air Conditioning
Division 26 – Electrical
Division 27 – Communications
Division 28 – Electronic Safety and Security
Division 31 – Earthwork
Division 32 – Exterior Improvements
Division 33 - Utilities

2. If the Engineer determines that additional detail is necessary, the Contractor shall provide it.
3. Each activity shall have a separate schedule bar. The schedule timeline shall be broken into weekly time periods with a vertical line to identify the first working day of each week.
4. The bar chart schedule shall show relationships among activities. The critical path for the Project shall be clearly defined on the schedule. The schedule shall show milestones for major elements of work, and shall be prepared on a sheet, or series of sheets of sufficient width to show data for the entire construction period.
5. If scheduling software is used to create the bar chart schedule, related reports such as a predecessor and successor report, a sort by total float, and a sort by early start shall also be submitted.
6. Project activities shall be scheduled to demonstrate that the construction completion date for the Project will occur prior to expiration of the Contract time. In addition, the schedule shall demonstrate conformance with any other dates stipulated in the Contract.
7. The Contractor is responsible to inform its subcontractor(s) and supplier(s) of the project schedule and any relevant updates.
8. There will be no direct payment for furnishing schedules, the cost thereof shall be considered as included in the general cost of the work.
9. For projects without a Mobilization item, 5% of the contract value will be withheld until such time as the Baseline Schedule is approved.

Monthly Updates: No later than the 10th day of each month, unless directed otherwise by the Engineer, the Contractor shall deliver to the Engineer three copies of the schedule to show the work actually accomplished during the preceding month, the actual time spent on each activity, and the estimated time needed to complete any

activity which has been started but not completed. Each time bar shall indicate, in 10% increments, the estimated percentage of that activity which remains to be completed. As the Project progresses, the Contractor shall place a contrasting mark in each bar to indicate the actual percentage of the activity that has been completed.

The monthly update shall include revisions of the schedule necessitated by revisions to the Project directed by the Engineer (including, but not limited to extra work), during the month preceding the update. Similarly, any changes of the schedule required due to changes in the Contractor's planning or progress shall also be included. The Engineer reserves the right to reject any such revisions. If the schedule revisions extend the contract completion date, due to extra or added work or delays beyond the control of the Contractor, the Contractor shall submit a request in writing for an extension of time in accordance with Article 1.08.08. This request shall be supported by an analysis of the schedules submitted previously.

Any schedule revisions shall be identified and explained in a cover letter accompanying the monthly update. The letter shall also describe in general terms the progress of the Project since the last schedule update and shall identify any items of special interest.

If the Contractor fails to provide monthly schedule updates, the Engineer has the right to hold 10% of the monthly estimated payment, or \$5,000, whichever is less, until such time as an update has been provided in accordance with this provision.

Biweekly Schedules: Each week, the Contractor shall submit to the Engineer a two week look-ahead schedule. This short-term schedule may be handwritten but shall clearly indicate all work planned for the following two week period.

Recovery Schedules: If the updated schedule indicates that the Project has fallen behind schedule, the Contractor shall either submit a time extension request in accordance with 1.08.08 or immediately institute steps acceptable to the Engineer to improve its progress of the Project. In such a case, the Contractor shall submit a recovery plan, as may be deemed necessary by the Engineer, to demonstrate the manner in which an acceptable rate of progress will be regained.

Add the following Article:

1.05.17 - WELDING

The Contractor shall ensure that all welding of materials permanently incorporated into the work, and welding of materials used temporarily during construction of the work is performed in accordance with the following codes:

- American Welding Society (AWS) Structural Welding Code – Steel – ANSI/AWS D1.1: Miscellaneous steel items that are statically loaded including but not limited to columns, and floor beams in buildings, railings, sign supports, cofferdams, tubular items, and modifications to existing statically loaded structures.
- AWS Structural Welding Code – Aluminum – AWS D1.2/D1.2M: Any aluminum structure or member including but not limited to brackets, light standards, and poles.

- AWS Structural Welding Code – Sheet Steel – AWS D1.3/D1.3M: Sheet steel and cold-formed members 0.18 in.(4.6 mm) or less in thickness used as, but not limited, to decking and stay-in-place forms.
- AWS Structural Welding Code – Reinforcing Steel – AWS D1.4/D1.4M: Steel material used in the reinforcement of cast-in-place or pre-cast Portland cement concrete elements including but not limited to bridge decks, catch basin components, walls, beams, deck units, and girders.
- AASHTO/AWS – Bridge Welding Code, AASHTO/AWS D1.5/D1.5M: Steel highway bridges and other dynamically loaded steel structures. Also includes sign supports, and any other fracture critical structure.

The edition governing the work shall be in effect on the date the Contract was advertised for solicitation of bids.

The Contractor is responsible to provide a Certified Welding Inspector in accordance with the above noted codes. The cost for this service is included in the general cost of the work.

All welders shall be certified by the Engineer in accordance with Section 6.03.

**CONNECTICUT
SUPPLEMENTAL SPECIFICATION
SECTION 1.08
PROSECUTION AND PROGRESS**

Article 1.08.01 – Transfer of Work or Contract:

Replace the last paragraph with the following:

The Contractor shall not sublet, sell, transfer, assign, or otherwise dispose of the Contract or any portion thereof, or of the work provided for therein, or of its right, title, or interest therein, to any individual or entity without the written consent of the Commissioner. No payment will be made for such work until written consent is provided by the Commissioner.

Article 1.08.07 – Determination of Contract Time:

Replace the fifth paragraph with the following:

The total elapsed time in calendar days, computed as described above, from the commencement date specified in the Engineer's "Notice to Proceed" to the "Substantial Completion" date specified in the Engineer's "Notice of Substantial Completion" shall be considered as the time used in the performance of the Contract work.

Article 1.08.09 – Failure to Complete Work on Time:

Replace the second paragraph with the following:

If the last day of the initial Contract time or the initial Contract date determined for Substantial Completion is before December 1 in the given year, liquidated damages as specified in the Contract shall be assessed against the Contractor per calendar day (including any days during a winter shutdown period) from that day until the date on which the Project is substantially completed.

1.08.12—Final Inspection:

Replace the first paragraph with the following:

If the Engineer determines that the work may be substantially complete, a Semi Final Inspection will be held as soon as practical. After the Semi Final Inspection is held and the Engineer determines that the requirements for Substantial Completion have been satisfied the Engineer will prepare a "Notice of Substantial Completion".

When the Contractor has completed all work listed in the “Notice of Substantial Completion” the Contractor shall prepare a written notice requesting a Final Inspection and a “Certificate of Acceptance of Work”. The Engineer will hold an Inspection of the Project as soon as practical after the Engineer determines that the Project may be completed. If the Engineer deems the Project complete, said inspection shall constitute the Final Inspection, and the Engineer will notify the Contractor in writing that the Final Inspection has been performed.

CONNECTICUT
SUPPLEMENTAL SPECIFICATION
SECTION 1.09
MEASUREMENT AND PAYMENT

Article 1.09.04 – Extra and Cost-Plus Work

Delete the word “bonding” under section (a) Labor, (3).

Delete existing section (e) and replace with the following:

(e) Administrative Expense: When extra work on a cost-plus basis is performed by an authorized subcontractor, the Department will pay the Contractor an additional 7.5% for that work; such payment will be in addition to the percentage payments described in (a), (b), (c) and (d) above, as a reimbursement for the Contractor's administrative expense in connection with such work. Approval of such additional payments will be given only after the Contractor provides to the Engineer receipted invoices for all relevant costs.

Change Section designation for Miscellaneous from:

(f) Miscellaneous to: **(g) Miscellaneous**

Add the following as (f):

(f) Bonding Costs: For bonding on the total cost of the cost-plus work including administrative expenses as outlined in (e) above, the Contractor shall receive its actual cost. The Contractor shall provide to the Engineer documentation, satisfactory to the Engineer in form and substance, of all such costs.

**CONNECTICUT
SUPPLEMENTAL SPECIFICATION
SECTION 1.10
ENVIRONMENTAL COMPLIANCE**

Add the following Article:

1.10.08 – VEHICLE EMISSIONS

All motor vehicles and/or construction equipment (both on-highway and non-road) shall comply with all pertinent State and Federal regulations relative to exhaust emission controls and safety.

The Contractor shall establish staging zones for vehicles that are waiting to load or unload at the contract area. Such zones shall be located where the emissions from the vehicles will have minimum impact on abutters and the general public.

Idling of delivery trucks, dump trucks, and other equipment shall not be permitted in excess of 3 minutes during periods of non-activity except as allowed by the Regulations of Connecticut State Agencies Section 22a-174-18(b)(3)(c):

No mobile source engine shall be allowed “to operate for more than three (3) consecutive minutes when the mobile source is not in motion, except as follows:

- (i) When a mobile source is forced to remain motionless because of traffic conditions or mechanical difficulties over which the operator has no control,
- (ii) When it is necessary to operate defrosting, heating or cooling equipment to ensure the safety or health of the driver or passengers,
- (iii) When it is necessary to operate auxiliary equipment that is located in or on the mobile source to accomplish the intended use of the mobile source,
- (iv) To bring the mobile source to the manufacturer’s recommended operating temperature,
- (v) When the outdoor temperature is below twenty degrees Fahrenheit (20 degrees F) [negative seven degrees Celsius (-7 degrees C)],
- (vi) When the mobile source is undergoing maintenance that requires such mobile source be operated for more than three (3) consecutive minutes, or
- (vii) When a mobile source is in queue to be inspected by U.S. military personnel prior to gaining access to a U.S. military installation.”

All work shall be conducted to ensure that no harmful effects are caused to adjacent sensitive receptors. Sensitive receptors include but are not limited to hospitals, schools, daycare facilities, elderly housing and convalescent facilities. Engine exhaust shall be located away from fresh air intakes, air conditioners, and windows.

A Vehicle Emissions Mitigation plan will be required for areas where extensive work will be performed within (less than 50 feet (15 meters)) to sensitive receptors. No work will proceed until a sequence of construction and a Vehicle Emissions Mitigation plan is submitted in writing to the Engineer for review and all comments are addressed in a manner acceptable to the Engineer. The mitigation plan must address the control of vehicle emissions from all vehicles and construction equipment.

Any costs associated with this "Vehicle Emissions" article shall be included in the general cost of the Contract. In addition, there shall be no time granted to the contractor for compliance with this notice. The contractor's compliance with this notice and any associated regulations shall not be grounds for claims as outlined in Section 1.11 – "Claims".

**CONNECTICUT
SUPPLEMENTAL SPECIFICATION
SECTION 1.11
CLAIMS**

Add the following Section:

1.11.01 – General: When filing a formal claim under Section 4-61 (referred to as “Section 4-61” below) of the C.G.S. (as revised), either as a lawsuit in the Superior Court or as a demand for arbitration, the Contractor must follow the procedures and comply with the requirements set forth in this Section of the Specifications. This Section does not, unless so specified, govern informal claims for additional compensation which the Contractor may bring before the Department. The Contractor should understand, however, that the Department may need, before the Department can resolve such a claim, the same kinds of documentation and other substantiation that it requires under this Section. It is the intent of the Department to compensate the Contractor for actual increased costs caused by or arising from acts or omissions on the part of the Department that violate legal or contractual duties owed to the Contractor by the Department.

1.11.02 – Notice of Claim: Whenever the Contractor intends to file a formal claim against the Department under Section 4-61, seeking compensation for additional costs, the Contractor shall notify the Commissioner in writing (in strict compliance with Section 4-61) of the details of said claim. Such written notice shall contain all pertinent information described in Article 1.11.05 below.

Once formal notice of a claim under C.G.S. Section 4-61 (b) (as revised) has been given to the Commissioner, the claimant may not change the claim in any way, in either concept or monetary amount, (1) without filing a new notice of claim and demand for arbitration to reflect any such change and (2) without the minimum period of six months after filing of the new demand commencing again and running before any hearing on the merits of the claim may be held. The only exception to this limitation will be for damages that continue to accrue after submission of the notice, in ways described and anticipated in the notice.

1.11.03 – Record Keeping: The Contractor shall keep daily records of all costs incurred in connection with its construction-related activities on behalf of the Department. These daily records shall identify each aspect of the Project affected by matters related to any claim for additional compensation that the Contractor has filed, intends to file, or has reason to believe that it may file against the Department; the specific Project locations where Project work has been so affected; the number of people working on the affected aspects of the Project at the pertinent time(s); and the types and number of pieces of equipment on the Project site at the pertinent time(s). If possible, any potential or anticipated effect on the Project’s progress or schedule which may result in a claim by the Contractor should also be noted contemporaneously with the cause of the effect, or as soon thereafter as possible.

1.11.04 – Claim Compensation: The payment of any claim, or any portion thereof, that is deemed valid by the Engineer shall be made in accordance with the following provisions of this Article:

(a) Compensable Items: The liability of the Department for claims will be limited to the following specifically-identified items of cost, insofar as they have not otherwise been paid for by the Department, and insofar as they were caused solely by the actions or omissions of the Department or its agents (except that with regard to payment for extra work, the Department will pay to the Contractor the mark-ups provided for in Article 1.04.05.):

- (1) Additional Project-site labor expenses.
- (2) Additional costs for materials.
- (3) Additional, unabsorbed Project-site overhead (**e.g.**, for mobilization and demobilization).
- (4) Additional costs for active equipment.
- (5) For each day of Project delay or suspension caused solely by actions or omissions of the Department, either
 - (i) an additional ten percent (10%) of the total amount of the costs identified in Subarticles (1) through (4) above; except that if the delay or suspension period prevented the Contractor from incurring enough Project costs under Subarticles (1) through (4) during that period to require a payment by the Department that would be greater than the payment described in subparagraph (ii) below, then the payment for affected home office overhead and profit shall instead be made in the following *per diem* amount:
 - (ii) six percent (6%) of the original total Contract amount divided by the original number of days of Contract time.Payment under either (i) or (ii) hereof shall be deemed to be complete and mutually-satisfactory compensation for any unabsorbed home office overhead and any profit related to the period of delay or suspension.
- (6) Additional equipment costs. Only actual equipment costs shall be used in the calculation of any compensation to be made in response to claims for additional Project compensation. Actual equipment costs shall be based upon records kept in the normal course of business and in accordance with generally-accepted accounting principles. Under no circumstances shall Blue Book or other guide or rental rates be used for this purpose (unless the Contractor had to rent the equipment from an unrelated party, in which case the actual rental charges paid by the Contractor, so long as they are reasonable, shall be used). Idle equipment, for instance, shall be paid for based only on its actual cost to the Contractor.
- (7) Subcontractor costs limited to, and determined in accordance with, Subarticles (1), (2), (3), (4), and (5) above and applicable statutory and case law. Such subcontractor costs may be paid for by the Department only (a) in the context of an informal claims settlement or (b) if the Contractor has itself paid or legally-assumed, present unconditional liability for those subcontractor costs.

(b) Non-Compensable Items: The Department will have no liability for the following specifically-identified non-compensable items:

- (1) Profit, in excess of that provided for herein.
- (2) Loss of anticipated profit.
- (3) Loss of bidding opportunities.
- (4) Reduction of bidding capacity.
- (5) Home office overhead in excess of that provided for in Article 1.11.04(a)(5) hereof.
- (6) Attorneys fees, claims preparation expenses, or other costs of claims proceedings or resolution.
- (7) Any other consequential or indirect expenses or costs, such as tort damages, or any other form of expense or damages not provided for in these Specifications or elsewhere in the Contract.

1.11.05 – Required Claim Documentation: All claims shall be submitted in writing to the Commissioner, and shall be sufficient in detail to enable the Engineer to ascertain the basis and the amount of each claim, and to investigate and evaluate each claim in detail. As a minimum, the Contractor must provide the following information for each and every claim and sub-claim asserted:

- (a) A detailed factual statement of the claim, with all dates, locations and items of work pertinent to the claim.
- (b) A statement of whether each requested additional amount of compensation or extension of time is based on provisions of the Contract or on an alleged breach of the Contract. Each supporting or breached Contract provision and a statement of the reasons why each such provision supports the claim, must be specifically identified or explained.
- (c) Excerpts from manuals or other texts which are standard in the industry, if available, that support the Contractor's claim.
- (d) The details of the circumstances that gave rise to the claim.
- (e) The date(s) on which any and all events resulting in the claim occurred, and the date(s) on which conditions resulting in the claim first became evident to the Contractor.
- (f) Specific identification of any pertinent document, and detailed description of the substance of any material oral communication, relating to the substance of such claim.
- (g) If an extension of time is sought, the specific dates and number of days for which it is sought, and the basis or bases for the extension sought. A critical path method, bar chart, or other type of graphical schedule that supports the extension must be submitted.

- (h) When submitting any claim over \$50,000, the Contractor shall certify in writing, under oath and in accordance with the formalities required by the contract, as to the following:
- (1) That supporting data is accurate and complete to the Contractors best knowledge and belief;
 - (2) That the amount of the dispute and the dispute itself accurately reflects what the Contractor in good faith believes to be the Departments liability;
 - (3) The certification shall be executed by:
 - a. If the Contractor is an individual, the certification shall be executed by that individual.
 - b. If the Contractor is not an individual, the certification shall be executed by a senior company official in charge at the Contractor's plant or location involved or an officer or general partner of the Contractor having overall responsibility for the conduct of the Contractors affairs.

1.11.06 – Auditing of Claims: All claims filed against the Department shall be subject to audit by the Department or its agents at any time following the filing of such claim. The Contractor and its subcontractors and suppliers shall cooperate fully with the Department's auditors. Failure of the Contractor, its subcontractors, or its suppliers to maintain and retain sufficient records to allow the Department or its agents to fully evaluate the claim shall constitute a waiver of any portion of such claim that cannot be verified by specific, adequate, contemporaneous records, and shall bar recovery on any claim or any portion of a claim for which such verification is not produced. Without limiting the foregoing requirements, and as a minimum, the Contractor shall make available to the Department and its agents the following documents in connection with any claim that the Contractor submits:

- (1) Daily time sheets and foreman's daily reports.
- (2) Union agreements, if any.
- (3) Insurance, welfare, and benefits records.
- (4) Payroll register.
- (5) Earnings records.
- (6) Payroll tax returns.
- (7) Records of property tax payments.
- (8) Material invoices, purchase orders, and all material and supply acquisition contracts.
- (9) Materials cost distribution worksheets.
- (10) Equipment records (list of company equipment, rates, etc.).
- (11) Vendor rental agreements
- (12) Subcontractor invoices to the Contractor, and the Contractor's certificates of payments to subcontractors.
- (13) Subcontractor payment certificates.
- (14) Canceled checks (payroll and vendors).
- (15) Job cost reports.
- (16) Job payroll ledger.

- (17) General ledger, general journal (if used), and all subsidiary ledgers and journals, together with all supporting documentation pertinent to entries made in these ledgers and journals.
- (18) Cash disbursements journals.
- (19) Financial statements for all years reflecting the operations on the Project.
- (20) Income tax returns for all years reflecting the operations on the Project.
- (21) Depreciation records on all company equipment, whether such records are maintained by the company involved, its accountant, or others.
- (22) If a source other than depreciation records is used to develop costs for the Contractor's internal purposes in establishing the actual cost of owning and operating equipment, all such other source documents.
- (23) All documents which reflect the Contractor's actual profit and overhead during the years that the Project was being performed, and for each of the five years prior to the commencement of the Project.
- (24) All documents related to the preparation of the Contractor's bid, including the final calculations on which the bid was based.
- (25) All documents which relate to the claim or to any sub-claim, together with all documents that support the amount of damages as to each claim or sub-claim.
- (26) Worksheets used to prepare the claim, which indicate the cost components of each item of the claim, including but not limited to the pertinent costs of labor, benefits and insurance, materials, equipment, and subcontractors' damages, as well as all documents which establish the relevant time periods, individuals involved, and the Project hours and the rates for the individuals.
- (27) The name, function, and pertinent activity of each Contractor's or subcontractor's official, or employee involved in or knowledgeable about events that give rise to, or facts that relate to, the claim.
- (28) The amount(s) of additional compensation sought and a break-down of the amount(s) into the categories specified as payable under Article 1.11.04 above.
- (29) The name, function, and pertinent activity of each Department official, employee or agent involved in or knowledgeable about events that give rise to, or facts that relate to, the claim.

**CONNECTICUT
SUPPLEMENTAL SPECIFICATION
SECTION 1.20
GENERAL CLAUSES FOR FACILITIES CONSTRUCTION**

1.20-1.00 – General:

Delete the last sentence of the first paragraph and replace with the following:

“Facilities Construction is defined as the type of construction that requires the issuance of a Certificate of Compliance (C.O.C.) by the State Building Inspector or his authorized representative at the completion of a project, and includes site work considered ancillary to this type of construction.”

Add the following article:

1.20-1.01.01—Definitions:

OWNER: Where used herein, it is synonymous with Department or State.

1.20-1.02.04 – Examination of Plans, Specifications, Special Provisions and Site of Work:

Delete the first sentence of the first paragraph and replace with the following:

“CSI-formatted specifications are organized into Divisions and Sections based on the CSI’s “MasterFormat” numbering system.”

1.20-1.02.13 – Knowledge of Applicable Laws:

Delete Items 1 through 9 in their entirety and replace with the following:

1. “The 2003 International Building Code with the State Building Code, including latest Connecticut Supplement and Amendments.
2. The 2003 International Plumbing Code.
3. The 2003 International Mechanical Code.
4. The 2003 International Existing Building Code.
5. The 2006 International Energy Conservation Code.
6. The 2005 NFPA 70 National Electrical Code.
7. The 2003 ICC/ANSI A117.1.

8. The Fire Safety Code, including latest Connecticut Supplement and Amendments.
9. The 2003 International Fire Code.
10. The 2003 NFPA 1 Uniform Fire Code.
11. The 2003 NFPA 101 Life Safety Code.”

Add the following as the new last paragraph:

“All work to be performed by the Contractor shall comply with the “Americans with Disabilities Act Accessibility Guidelines.”

1.20-1.03.01 – Consideration of Bids:

Delete the entire article and replace with the following:

“The apparent low bidder shall submit to the Manager of Contracts a Schedule of Values within 14 days after bid opening. Any other Contractor that the Department may subsequently designate as the apparent lowest bidder shall make the aforesaid submission within 14 days from the date on which the Department notifies said Contractor that it has become the apparent lowest bidder. If, however, the Department deems it necessary for such a subsequently designated Contractor to make said submission within a shorter period of time, the Contractor shall make the submission within the time designated by the Department.

The total in the Schedule of Values shall equal the bid dollar amount for the Major Lump Sum Item (MLSI).

The Schedule of Values shall be divided into “Line Items” listed separately for each CSI Section of the Special Provisions. An additional line item for “Mobilization” may be incorporated into the Schedule of Values; however, this item may not exceed 10% of the value of the MLSI. The “Mobilization” line item will also include costs associated with “General Conditions” and “Insurance/Bonding.” Where requested by the Department, the Contractor shall break down the line items further into more specific line items.

In the event that this Contract is terminated or a portion of this Contract is deleted for any reason or in any way allowable by law under this Contract after the apparent low bidder has been awarded the Contract, the Schedule of Values will not be used for estimating payment due the Contractor for work completed prior to such termination of the Contract or deletion of work thereunder. In the case of Contract termination, payment shall be made in accordance with Article 1.05.14.”

1.20-1.05.02--Shop Drawings, Product Data, Product Samples and Quality Assurance Submittals

Delete the last sentence of the first paragraph and replace with the following:

“All facsimiles or other electronic documents from the Contractor shall be followed by an official transmittal.”

Delete the third paragraph and replace with the following:

“The Contractor shall number each submittal consecutively: When resubmitting a “Revise and Resubmit” or “Rejected” submittal, the Contractor shall label the transmittal with the original submittal number followed by a letter to designate the additional submission. All submittals shall be numbered conforming to the following examples:”

In column B of line 001, line 001a, and line 001b of the table in subsection 1, replace “07511” with “075110.”

Add the following to the end of the first paragraph of subsection 2:

“The Department reserves the right to return partial submittals unreviewed to the Contractor.”

Revise the third paragraph of subsection 2 to read:

“The Contractor shall allow at least 60 calendar days for review of any submittal requiring approval by FAA, FTA, any railroad, DEP, U.S. Coast Guard, Army Corps of Engineers, or any other outside agency.”

Delete the third and fourth paragraphs of subsection 3 and replace with the following:

“The Designer will not review submittals and the Engineer will not process payment estimates until the initial submittal schedule has been provided. Any delays in construction due to the Contractor's failure to provide a submittal schedule shall be the responsibility of the Contractor.

The Contractor must update its submittal schedule at least once a month, and distribute and post each updated schedule in the manner described above. The Engineer reserves the right not to process payment estimates without a recently updated submittal schedule on file.”

Replace the first sentence of the first paragraph of subsection 4 with the following:

“Shop Drawings consist of fabrication and installation drawings, roughing-in and setting drawings, schedules, patterns, templates and similar drawings, and wiring diagrams showing field-installed wiring, including power, signal, and control wiring.”

Replace the second paragraph of subsection 4 with the following:

“Shop drawings shall include the following information: Contract number, Project description, number and title of the drawing, date of drawing, revision number, name of Contractor and subcontractor submitting drawings, dimensions, identification of products, shopwork manufacturing instructions, design calculations, statement of compliance with Contractual standards, notation of dimensions established by field measurement, relationship to adjoining construction clearly indicated, seal and signature of a professional engineer if specified, and any other information required by individual Contract provisions.”

Replace the first sentence of the first paragraph of subsection 5 with the following:

“Product data consist of printed information such as manufacturer’s product specifications, manufacturer’s installation instructions, manufacturer’s catalog cuts, standard color charts, wiring diagrams showing factory-installed wiring, printed performance curves, operational range diagrams, and mill reports.”

Replace the first sentence of the first paragraph of subsection 7 with the following:

“Quality assurance submittals consist of qualification data, design data, certifications, manufacturer’s instructions, manufacturer’s field reports, test reports, Material Safety Data Sheets (MSDSs), and other quality assurance information required by individual Contract provisions.”

1.20-1.05.04—Coordination of Special Provisions, Plans, Supplemental Specifications and Standard Specifications and Other Contract Requirements:

Delete the first and second paragraphs and replace with the following:

“Industry Standards: Each entity engaged in construction of the Contract shall be familiar with industry standards applicable to that entity's construction activities. If printed standards have been established by organizations referenced in Article 1.01.02 or in the Contract, the Contractor shall obtain copies of said standards directly from the publication source.

Unless the Special Provisions include more stringent requirements, applicable construction industry standards have the same force and effect as if bound or copied directly into the Special Provisions to the extent referenced. Such standards are made a part of the Contract by reference.”

Add the following article:

1.20-1.05.08—Schedules and Reports:

Daily Construction Reports: The Contractor shall assist the Engineer in the preparation of a daily construction report, by ensuring that each of the Contractor's employees and subcontractors working on the Project site on a given day signs the Engineer's sign-in sheet for that day; and by keeping and providing to the Engineer its own daily list of employees and subcontractors who worked on the Project site on that day.

Add the following article:

1.20-1.05.23—Requests for Information (RFIs):

The Contractor shall forward all RFIs to the Engineer in writing (facsimile or other electronic document) for review. The Engineer will forward the RFI to the Designer for review. Upon receipt of an RFI, the Designer will attempt to determine if additional information is required from the Contractor to respond to the RFI, and request said information from the Engineer.

All other RFIs will be responded to within 10 calendar days of receipt by the Designer.

1.20-1.05.24--Project Meetings:

Delete the third paragraph under subsection 1.

Delete the second paragraph under subsection 2 and replace with the following:

"The meeting participants shall review progress of other construction activities and preparations for the particular activity under consideration, including requirements of Contract documents, related requests for interpretations, related construction orders, purchases, deliveries, submittals, review of mockups, possible conflicts, compatibility problems, time schedules, weather limitations, manufacturer's written recommendations, warranty requirements, compatibility of materials, acceptability of substrates, temporary facilities and controls, space and access limitations, regulations of authorities having jurisdiction, testing and inspecting requirements, installation procedures coordination with other work, required performance results, protection of adjacent work, and protection of construction and personnel."

Delete the second, third and fourth paragraph under subsection 3 and replace with the following:

"The Contractor shall provide the Engineer with a detailed agenda for the proposed

meeting, specifying what topics will be covered. In addition to representatives of the Engineer, each subcontractor, supplier or other entity concerned with current progress or involved in planning, coordination or performance of future activities shall attend these meetings. All participants at the meeting shall be familiar with the Project and authorized to conclude matters relating to the Project.

At each progress meeting, the participants shall (1) review items of significance that could affect progress; (2) discuss topics appropriate to the current status of the Project; (3) review progress since the last meeting; (4) determine whether each activity is on time, ahead of schedule, or behind schedule, in relation to the Contractor's Construction Schedule; (5) determine how to expedite any Project work that may be behind schedule; (6) discuss whether or not schedule revisions are required to ensure that current and subsequent activities will be completed within the Contract time; and (7) review the present and future needs of each entity represented at the meeting, including such items as interface requirements, time, sequences, deliveries, off-site fabrication problems, access, site utilization, temporary facilities and controls, hours of work, hazards and risks, housekeeping, quality and work standards, status of correction of deficient items, field observations, requests for interpretations, status of proposal requests, pending changes, status of construction orders, and documentation of information for payment requests. The Engineer will distribute copies of minutes of the meeting to the Designer and the Contractor. The Contractor shall distribute copies to parties who were or should have been at the meeting.”

Delete article 1.20-1.05.25—Schedules and Reports in its entirety

1.20-1.06.08 - Warranties:

Delete the eighth and ninth paragraph and replace with the following:

“The Contractor shall:

(a) Bind warranties in heavy-duty, commercial-quality, durable 3-ring vinyl-covered loose-leaf binders, thick enough to accommodate the contents, and sized to receive 8 1/2-inch x 11-inch paper (216-millimeter x 279-millimeter) paper.

(b) Identify the binder's contents on the binder's front and spine with the typed or printed title “WARRANTIES,” the Project title or name, and the name of the Contractor.

(c) Provide a heavy paper divider with a tab for each separate warranty.

(d) Mark the tab to identify the related product or installation.

(e) Provide a typed description of the product or installation, including the name of the product, and the name, address and telephone number of the Contractor or pertinent subcontractor.

(f) Furnish to the Department a written warranty for all Project work accompanied by a cover letter with the following contents:

[Addressed to:]

Commissioner of Transportation
Department of Transportation
P.O. Box 317546
Newington, Connecticut 06131-7546

Project Title and Number

[We] hereby warrant all materials and workmanship for all work performed under this Contract for a period of one (1) year from [date of issuance of C.O.C.] against failures of workmanship and materials in accordance with the Contract. Furthermore, as a condition of this warranty, [we] agree to have in place all insurance coverage identified in the Contract for the performance of any warranty work.

[Signature:] [Name of authorized signatory]
[Title]

(g) Submit to the Engineer, upon completion of installation of materials or assemblies that are required to have either a flame-rating or a fire-endurance hourly rating, a detailed letter certifying that the required rating has been attained.

Upon determination by the Engineer that Project work covered by a warranty has failed, the Contractor shall replace or rebuild the work to an acceptable condition complying with Contract requirements. The Contractor is responsible for the cost of replacing or rebuilding defective construction or components and those which may have needed to be damaged or removed in order to cure the defective work including costs of material, equipment, labor, and material disposal, regardless of whether or not the State has benefited from use of the work through a portion of its anticipated useful service life. The Contractor shall respond to the Project Site when Project work covered by a warranty has failed within 3 calendar days, unless in the Engineer's opinion said failure is deemed to be an emergency, in which case the Contractor shall respond to the Project Site as directed by the Engineer."

1.20-1.08.03—Prosecution of Work:

Under subsection '3. Cutting and Patching,' delete the heading 'B. Protection of Structural Elements' and replace with the following:

"B. Protection:"

Move the existing first and second paragraphs to under the following subparagraph:

"1. Structural Elements:"

Add the following after the first paragraph under B:

“2. Operational Elements: The Contractor shall not cut and patch operating elements and related components in a manner that results in their reducing their capacity to perform as intended or that results in increased maintenance or decreased operational life or safety.

3. Miscellaneous Elements: The Contractor shall not cut and patch miscellaneous elements or related components in a manner that could change their load-carrying capacity, that results reducing their capacity to perform as intended, or that results in increased maintenance or decreased operational life or safety.”

Add the following after subsection 3:

“4. Selective Demolition:

A. Definitions:

Remove: The Contractor shall detach materials from existing construction and legally dispose or recycle them off-site, unless indicated to be removed and salvaged or removed and reinstalled. Except for materials indicated to be reused, salvaged,

reinstalled, or otherwise indicated to remain Engineer's property, demolished materials shall become Contractor's property and shall be removed from the Project Site.

Remove and Salvage: The Contractor shall detach materials from existing construction and deliver them to Engineer. The Engineer reserves the right to identify other materials for salvage during the course of demolition.

Remove and Reinstall: The Contractor shall detach materials from existing construction, prepare them for reuse, and reinstall them where indicated.

Existing to Remain: Existing materials of construction that are not to be removed and that are not otherwise indicated to be removed, removed and salvaged, or removed and reinstalled.

B. Approval Process:

The Contractor shall submit pre-demolition photographs to the Engineer prior to the commencement of Project work to show existing conditions of adjoining construction and site improvements, including finish surfaces, that might be misconstrued as damage caused by selective demolition operations.

Well in advance of performing any selective demolition on the Project, the Contractor shall submit to the Engineer a proposal describing the procedures that the Contractor intends to use for same.

The Contractor shall include the following information, as applicable, in its proposal: (1) detailed sequence of selective demolition and removal work with starting and ending dates for each activity while ensuring that the Engineer's on-site operations are not disrupted; (2) interruption of utility services; (3) coordination for shutoff, capping, and continuation of utility services; (4) use of elevators and stairs; (5) locations of temporary partitions and means of egress; (6) coordination of Engineer's continuing occupancy of

portions of existing building and of Engineer's partial occupancy of completed Project work; and (7) means of protection for items to remain and items in path of waste removal from building.

The Contractor shall comply with (1) governing EPA notification regulations before beginning selective demolition; (2) hauling and disposal regulations of authorities having jurisdiction; (3) ANSI A10.6; and (4) NFPA 241.

The Engineer will conduct a Pre-Demolition Meeting at the Project site in accordance with Article 1.20-1.05.24. Said meeting will review the methods and procedures related to selective demolition including, but not limited to, the following: (1) an inspection and discussion of the condition of construction to be selectively demolished; (2) a review of the structural load limitations of the existing structure; (3) a review and finalization of the

selective demolition schedule and a verification of the availability of materials, demolition personnel, equipment, and facilities needed to make progress and avoid delays; (4) a review of requirements of Project work performed by other trades that rely on substrates exposed by selective demolition operations; and (5) a review of areas where existing construction is to remain and requires protection.

C. Repair Materials:

The Contractor shall comply with Article 1.20-1.08.03 subsection 3E for repair materials and shall comply with material and installation requirements specified in other Contract provisions.

D. Examination:

The Contractor shall (1) verify that utilities have been disconnected and capped; (2) survey existing conditions and correlate with requirements indicated to determine extent of selective demolition required; (3) inventory and record the condition of items to be removed and reinstalled and items to be removed and salvaged; (4) investigate and measure the nature and extent of unanticipated mechanical, electrical, or structural elements that conflict with intended function or design and submit a written report to

Engineer; and (5) perform surveys as the Project work progresses to detect hazards resulting from selective demolition activities.

E. Utility Services:

The Contractor shall (1) maintain existing utility services indicated to remain and protect them against damage during selective demolition operations; (2) not interrupt existing utilities serving occupied or operating facilities unless authorized in writing by the Engineer; (3) provide temporary services during interruptions to existing utilities, as acceptable to Engineer; (4) provide at least 3 calendar days notice to the Engineer if shutdown of service is required during changeover; and (5) locate, identify, disconnect,

and seal or cap off indicated utilities serving areas to be selectively demolished. The Contractor shall arrange to shut off indicated utilities with utility companies. If utility services are required to be removed, relocated, or abandoned, before proceeding with selective demolition the Contractor shall provide temporary utilities that bypass area of selective demolition and that maintain continuity of service to other parts of building. The Contractor shall cut off pipe or conduit in walls or partitions to be removed and shall cap, valve, or plug and seal remaining portion of pipe or conduit after bypassing.

The Contractor shall refer to other Contract provisions for shutting off, disconnecting, removing, and sealing or capping utilities. The Contractor shall not start selective demolition work until utility disconnecting and sealing have been completed and verified by the Engineer in writing.

F. Preparation:

The Contractor shall conduct selective demolition and debris-removal operations to ensure minimum interference with adjacent occupied and used facilities on the Project site. The Contractor shall not disrupt the Owner's operations without the Engineer's permission. The Contractor shall protect existing site improvements, appurtenances, and landscaping to remain.

The Contractor shall provide temporary barricades and other protection required to prevent injury to people and damage to adjacent buildings and facilities to remain. The Contractor shall provide temporary weather protection, during interval between selective demolition of existing construction on exterior surfaces and new construction, to prevent water leakage and damage to structure and interior areas. The Contractor shall protect walls, ceilings, floors, and other existing finish work that are to remain or that are exposed during selective demolition operations. The Contractor shall cover and protect furniture, furnishings, and equipment that have not been removed.

The Contractor shall provide temporary enclosures for protection of existing building

and construction, in progress and completed, from exposure, foul weather, other construction operations, and similar activities. The Contractor shall provide temporary weathertight enclosure for building exterior. Where heating is needed and permanent enclosure is not complete, the Contractor shall provide insulated temporary enclosures and shall coordinate enclosure with ventilating and material drying or curing requirements to avoid dangerous conditions and effects.

The Contractor shall erect and maintain dustproof partitions and temporary enclosures to limit dust and dirt migration and to separate areas from fumes and noise.

The Contractor shall provide and maintain interior and exterior shoring, bracing, or structural support to preserve stability and prevent movement, settlement, or collapse of construction to remain, and to prevent unexpected or uncontrolled movement or collapse of construction being demolished. The Contractor shall strengthen or add new supports when required during progress of selective demolition.

G. Pollution Controls:

The Contractor shall comply with governing regulations pertaining to environmental protection.

The Contractor shall not use water when it may create a hazardous or objectionable condition such as ice, flooding, or pollution.

The Contractor shall remove and transport debris in a manner that will prevent spillage on adjacent surfaces and areas. The Contractor shall remove debris from elevated portions of building by chute, hoist, or other device that will convey debris to grade level in a controlled descent.

The Contractor shall clean adjacent structures and improvements of dust, dirt, and debris caused by selective demolition operations. The Contractor shall return adjacent areas to condition existing before selective demolition operations began.

H. Performance:

The Contractor shall not use explosives for demolition purposes.

The Contractor shall demolish and remove existing construction only to the extent required by new construction and as indicated. The Contractor shall (1) proceed with selective demolition systematically; (2) neatly cut openings and holes plumb, square, and true to dimensions required; (3) use cutting methods least likely to damage

remaining or adjoining construction; (4) use hand tools or small power tools designed for sawing or grinding, not hammering and chopping, to minimize disturbance of adjacent surfaces; (5) temporarily cover openings to remain; (6) cut or drill from the

exposed or finished side into concealed surfaces to avoid marring existing finished surfaces; (7) not use cutting torches until work area is cleared of flammable materials; (8) verify condition and contents of concealed spaces such as duct and pipe interiors before starting flame-cutting operations; (9) maintain fire watch and portable fire-suppression devices during flame-cutting operations; (10) maintain adequate ventilation when using cutting torches; (11) remove decayed, vermin-infested, or otherwise dangerous or unsuitable materials and promptly dispose of off-site; (12) remove structural framing members and lower to ground by method suitable to avoid free fall and to prevent ground impact or dust generation; (13) locate selective demolition equipment and remove debris and materials so as not to impose excessive loads on supporting walls, floors, or framing; and (14) dispose of demolished items and materials promptly.

The Contractor shall comply with the Engineer's requirements for using and protecting walkways, building entries, and other building facilities during selective demolition operations.

The Contractor shall demolish and remove foundations and other below grade structures completely unless otherwise indicated on the plans. The Contractor shall fill below grade areas and voids resulting from demolition of structures with granular fill materials. Prior to placement of fill materials, the Contractor shall ensure that the areas to be filled are free of standing water, frost, frozen material, trash, and debris. After fill placement and compaction, grade surface to meet adjacent contours and provide flow

to surface drainage structures. Backfilling and grading related to demolition is included in the Major Lump Sum Item (MLSI) for the Project. There will be no separate payment for this backfilling and grading.

The Contractor shall (1) demolish concrete in sections; (2) cut concrete at junctures with construction to remain to the depth shown on the Contract plans and at regular intervals using power-driven saw; and (3) remove concrete between saw cuts.

The Contractor shall (1) demolish masonry in small sections; (2) cut masonry at junctures with construction to remain using power-driven saw; and (3) remove masonry between saw cuts.

The Contractor shall (1) saw-cut perimeter of concrete slabs-on-grade to be demolished as shown on the Contract plans; and (2) break up and remove concrete slabs-on-grade.

The Contractor shall (1) remove floor coverings and adhesive according to recommendations in RFCI-WP and its Addendum; and (2) remove residual adhesive and prepare substrate for new floor coverings by one of the methods recommended by RFCI.

The Contractor shall (1) only remove existing roofing in one day to the extent that it can

be covered by new roofing; and (2) refer to other Contract provisions for new roofing requirements.

The Contractor shall remove air conditioning equipment without releasing refrigerants.

I. Reuse of Building Elements:

The Contractor shall not demolish building elements beyond what is indicated on the plans without the Engineer's approval.

J. Removed and Salvaged Materials:

Unless otherwise directed by the Engineer, the Contractor shall (1) store materials in a secure area until delivery to the owner; (2) transport materials to the owner's storage area off-site; and (3) protect materials from damage during transport and storage.

K. Removed and Reinstalled Materials:

Unless otherwise directed by the Engineer, the Contractor shall (1) clean and repair materials to functional condition adequate for intended reuse; (2) paint equipment to match the color of new equipment; (3) protect materials from damage during transport and storage; and (4) reinstall items in locations indicated complying with installation requirements for new materials and equipment and providing connections, supports, and miscellaneous materials necessary to make item functional for use indicated.

L. Existing Materials to Remain:

The Contractor shall protect construction indicated to remain against damage and soiling during selective demolition.

The Contractor shall drain piping and cap or plug piping with the same or a compatible piping material for piping to be abandoned in place.

The Contractor shall cap or plug ducts with the same or a compatible ductwork material for ducts to be abandoned in place.

The Contractor shall cut and remove concealed conduits and wiring to be abandoned in place 2-inches (50-mm) below the surface of the adjacent construction, cap the conduit end, and patch the surface to match the existing finish. The Contractor shall cut existing conduits installed in concrete slabs to be abandoned in place flush with the top of the slab and fill conduit end with a minimum of 4-inches (100-mm) of concrete.

M. Patching and Repairing:

The Contractor shall comply with Article 1.20-1.08.03 subsection 3H for patching and

repairing damage to adjacent construction caused by selective demolition operations.

N. Disposal of Demolished Materials:

The Contractor shall (1) not allow demolished materials to accumulate or be sold on the Project Site; (2) not burn demolished materials on the Project Site; and (3) promptly and legally dispose or recycle demolished materials off the Project Site.”

1.20-1.08.05--Personnel and Equipment:

Replace “FM with “FMG” in subsection (a)

Add the following article:

“1.20-1.08.12--Semi-Final and Final Inspections:

1. Semi-Final Inspection: Before requesting the Semi-Final Inspection, the Contractor shall show 100% completion for all Project work claimed as complete. The Contractor shall submit final test/adjust/balance records including the final air and water balance report. For all incomplete Project work, the Contractor shall prepare its own “Punch List” of the incomplete items and reasons the work is not complete. The Contractor shall submit final test/adjust/balance records including the final air and water balance report.

On receipt of a Contractor request for inspection, the Engineer will proceed with inspection or notify the Contractor of unfulfilled requirements. The Engineer will prepare a “Punch List” of unfilled, substandard, or incomplete items. During this inspection, the Contractor shall have all technicians necessary to demonstrate the complete operation of all systems on-site. Examples of such systems include, but are not limited to, the following: boiler, HVAC, fire alarm, and building automation. The Engineer will advise the Contractor of the construction that must be completed or corrected before the issuance of the C.O.C. Results of the completed inspection will form the basis of requirements for the Final Inspection. The Engineer reserves the right to issue the C.O.C. after the Semi-Final Inspection if there are no Building Code or Fire Code compliance issues or any major “Punch List” items.

2. Final Inspection: Before requesting Final Inspection for issuance of the C.O.C., the Contractor shall: (1) submit specific warranties, maintenance service agreements, final certifications and similar documents; (2) submit Record Drawings, Record Specifications, operations and maintenance manuals, final project photographs, property surveys, and similar final record information; (3) deliver spare parts; (4) make final changeover of permanent locks and deliver the keys to the Engineer; (5) complete start-up testing of systems; (6) train the owner's operation and maintenance personnel; (7) discontinue or change over and remove temporary facilities from the Project Site, along with construction tools, mock-ups, and similar elements; (8) complete final

cleaning requirements, including touch-up painting; (9) touch-up and otherwise repair and restore marred exposed finishes to eliminate visual defects; (10) submit a certified copy of the Engineer's "Punch List" of items to be completed or corrected, stating that each item has been completed or otherwise resolved for acceptance, and the list has been endorsed and dated by the Engineer; (11) submit final meter readings for utilities, a measured record of stored fuel, and similar data as of the date of Final Inspection, or when the Engineer took possession of and responsibility for corresponding elements of the Project work; and (12) install permanent electrical service. The Contractor shall

install permanent electrical service prior to Semi-Final Inspection if requested by the Engineer, or if necessary for the Engineer or Contractor to perform testing of building and other related systems and equipment to certify acceptance and completion of Project work. The Contractor shall submit all outstanding items or unacceptable submissions from the Semi-Final Inspection, or other outstanding items required for submittal, prior to the Final Inspection.

On receipt of a Contractor request for inspection, the Engineer will proceed with inspection and notify the Contractor of unfulfilled requirements."

1.20 – 1.08.13 – Termination of the Contractor's Responsibility:

Add subsection 3 as follows:

"3. Insurance Coverage: The Contractor shall have in place all insurance coverage identified in Article 1.03.07 for the performance of any warranty work."

1.20-1.08.14--Acceptance of Project:

Add the following to subsection 2 under the heading "Equipment and Systems Maintenance Manual:"

"(j) Copies of maintenance agreements with service agent name and telephone number."

Add the following paragraph in subsection 3 after the second paragraph:

"The Contractor shall provide a syllabus prior to the training to ensure that the appropriate owner's operation and maintenance personnel are in attendance."

Delete the last paragraph and replace with the following:

The Contractor shall submit to the Engineer for approval, a qualified commercial videographer to videotape the training sessions. The videographer shall be a firm or an individual of established reputation that has been regularly engaged as a professional videographer for not less than 3 years.

The Contractor shall video record each training session and provide said video in DVD format to the Engineer for the owner's future use."

Add the following section:

"1.20-1.09.06—Partial Payments:

With each payment request under the MLSI, the Contractor shall submit AIA Form G702 (Application and Certificate of Payment) and Form G703 (Continuation Sheet). The Contractor is not required to obtain the Architect's signature on Form G702. Once approved by the Engineer, the Forms G702 and G703 become the basis of payment under the MLSI."

Add the following section:

"1.20-9.75.04—Method of Measurement:

Mobilization as defined in Article 1.20-1.03.01 will be paid in the manner described hereinafter; however, the determination of the total contract price earned shall not include the amount of mobilization earned during the period covered by the current monthly estimate – but shall include amounts previously earned and certified for payment:

1. When the first payment estimate is made, 25 percent of the "Mobilization" line item will be certified for payment.
2. When the Baseline Schedule, as specified under Section 1.05.08, is accepted, 50 percent of the "Mobilization" line item, minus any previous payments, will be certified for payment.
3. When 10 percent of the total original contract price is earned and the Baseline Schedule, as specified under Section 1.05.08, is accepted, 75 percent of the "Mobilization" line item, minus any previous payments, will be certified for payment.
4. When 30 percent of the total original contract price is earned and the Baseline Schedule, as specified under Section 1.05.08, is accepted, 100 percent of the "Mobilization" line item, minus any previous payments, will be certified for payment."

**CONNECTICUT
SUPPLEMENTAL SPECIFICATION
SECTION 2.02
ROADWAY EXCAVATION, FORMATION OF
EMBANKMENT AND DISPOSAL OF
SURPLUS MATERIAL**

2.02.04 – Method of Measurement:

Second to last Paragraph - replace the last sentence with the following:

“Bituminous parking areas are considered as bituminous concrete pavement.”

**CONNECTICUT
SUPPLEMENTAL SPECIFICATION
SECTION 2.05
TRENCH EXCAVATION**

Delete the entire Section and replace with the following:

2.05.01--Description:

Paragraph 2 - Delete the only sentence and replace with the following:

2) The removal of stormwater drainage structures, stormwater pipes and appurtenances beyond the limits of the roadway and structure excavation.

Sub article 2 - Rock in Trench - Delete the only sentence and replace with the following:

(2) Rock, insofar as it applies to trench excavation, shall be defined as rock in definite ledge formation, boulders, or portions of boulders, cement masonry structures, concrete structures, reinforced concrete pipe, Portland cement concrete pavement or base, of 1/2 cubic yard (0.5 cubic meters) or more in volume, removed as indicated or directed from within the payment lines for trench excavation.

2.05.05 -Basis of Payment

Paragraph 13 - Delete the entire sentence "There will be no direct payment for the plugging of existing pipes....." and replace with the following:

There will be no direct Payment for the plugging of existing pipes, removal and disposal of metal or plastic pipes or for the breaking up of floors in drainage structures being abandoned. The cost shall be included in the contract unit prices of the drainage and excavation items.

**CONNECTICUT
SUPPLEMENTAL SPECIFICATION
SECTION 3.04
PROCESSED AGGREGATE BASE**

Delete the entire Section and replace with the following:

3.04.01--Description: The base shall consist of a foundation constructed on the prepared subbase or subgrade in accordance with these specifications and in conformity with the lines, grades, compacted thickness and typical cross-section as shown on the plans.

3.04.02--Materials: All materials for this work shall conform to the requirements of Article M.05.01.

3.04.03--Construction Methods: Only one type of coarse aggregate shall be used on a project unless otherwise permitted by the Engineer.

Prior to placing the processed aggregate base, the prepared subbase or subgrade shall be maintained true to line and grade, for a minimum distance of 200 feet (60 meters) in advance of the work. None of the aggregate courses shall be placed more than 500 feet (150 meters) ahead of the compaction and binding operation on that particular course.

The processed aggregate base shall be spread uniformly by a method approved by the Engineer. The thickness of each course shall not be more than 4 inches (100 millimeters) after compaction, unless otherwise ordered.

After the aggregate is spread, it shall be thoroughly compacted and bound by use of equipment specifically manufactured for that purpose. Rollers shall deliver a ground pressure of not less than 300 pounds per lineal inch (52.5 newtons/millimeter) of contact width and shall have a weight (mass) not less than 10 tons (9100 kilograms). Vibratory units shall have a static weight (mass) of not less than 4 tons (3650 kilograms). Water may be used during the compaction and binding operation and shall be applied from an approved watering device. The compacting and binding operation shall begin at the outside edges, overlapping the shoulders for a distance of not less than 6 inches (150 millimeters) and progress towards the middle, parallel with the centerline of the pavement. The work shall cover the entire surface of the course with uniform overlapping of each preceding track or pass. Areas of super-elevation and special cross slope shall be compacted by beginning at the lowest edge and proceeding towards the higher edge, unless otherwise directed by the Engineer. The compacting and binding operation shall be continued until the voids in the aggregates have been reduced to provide a firm and uniform surface satisfactory to the Engineer. The amount of compactive effort shall in no case shall be less than four (4) complete passes of the compacting and binding operations. All aggregate shall be completely compacted and bound at the end of each day's work or when traffic is to be permitted to operate on the

road. The dry density of each layer of processed aggregate base after compaction shall not be less than 95 percent of the dry density for that material when tested in accordance with AASHTO T180, Method D.

Should the subbase or subgrade material become churned up or mixed with the processed aggregate base at any time, the Contractor shall, without additional compensation remove the mixture. The Contractor shall add new subbase material, if required, and reshape and recompact the subbase in accordance with the requirements of Article 2.12.03. New aggregate material shall be added, compacted and bound, as hereinbefore specified, to match the surrounding surface.

Any surface irregularities which develop during, or after work on each course, shall be corrected by loosening material already in place and removing or adding aggregate as required. The entire area, including the surrounding surface, shall be re-compacted and rebound until it is brought to a firm and uniform surface satisfactory to the Engineer.

3.04.04--Method of Measurement: Processed Aggregate Base will be measured horizontally in-place after final grading and compaction. Materials placed beyond the horizontal limits indicated on the plans will not be measured for payment.

The total thickness shall be as indicated on the plans, or as ordered by the Engineer and within a tolerance of minus three-fourths of an inch ($-\frac{3}{4}$ ") to plus one-half inch ($+\frac{1}{2}$ ") (-19 millimeters to +13 millimeters).

Measurements to determine the thickness will be taken by the Engineer at intervals of 500 feet (150 meters) or less, along lanes, and shall be considered representative of the lane. For the purpose of these measurements, a shoulder will be considered a lane.

If a thickness measurement is taken and found deficient, the Engineer will take such additional measurements as he considers necessary to determine the longitudinal limits of the deficiency. Areas not within allowable tolerances shall be corrected, as ordered by the Engineer, without additional compensation to the Contractor.

3.04.05--Basis of Payment: This work will be paid for at the contract unit price per cubic yard for "Processed Aggregate Base", complete in place, which price shall include all materials, tools, equipment and work incidental thereto.

Pay Item	Pay Unit
Processed Aggregate Base	c.y. (cu. m)

**CONNECTICUT
SUPPLEMENTAL SPECIFICATION
SECTION 4.01
CONCRETE PAVEMENT**

Article 4.01.03-A. Composition:

Add the following new paragraph before the last paragraph:

“The temperature of the concrete at the time of placement shall not be less than 60° F (15.5° C) or greater than 90° F (32° C). For pumped concrete, the temperature shall be determined at the placement end of the pump line. The temperature of the concrete shall be determined in accordance with ASTM C1064.”

**CONNECTICUT
SUPPLEMENTAL SPECIFICATION
SECTION 5.14
PRESTRESSED CONCRETE MEMBERS**

Article 5.14.03 – Construction Methods:

Change the last sentence of 5.14.03-16 – Methods and Equipment to read:

“The results of this investigation, including computations, shall be submitted to the Engineer.”

**CONNECTICUT
SUPPLEMENTAL SPECIFICATION
SECTION 6.01
CONCRETE FOR STRUCTURES**

Article 6.01.02 – Materials:

Add the following:

Material for stay-in-place metal forms shall be made of zinc-coated (galvanized) steel sheet conforming to ASTM Specification A653, Structural Steel (SS) Grade 33 through 80 (ASTM Specification A653M, Structural Steel (SS) Grade 250 through 550). The minimum gage thickness shall be 20 gage. Coating weight shall conform to ASTM A924, Class G235 (ASTM A924M, Class Z700) and shall otherwise meet all requirements relevant to steel stay-in-place metal forms and the placing of concrete as specified herein and as noted on the contract drawings.

Material for the form supports shall be fabricated from the same material and conform to the same material requirements as the forms themselves or they shall be fabricated from structural steel conforming to the requirements of ASTM A36 (ASTM A36M) which shall be hot-dip galvanized in accordance with ASTM A123 (ASTM A123M).

Lightweight filler material shall be as recommended by the form's manufacturer.

Subarticle 6.01.03 – 3, Forms:

Add the following:

Stay-in-Place Metal Form System:

Stay-in-place metal forms shall have a minimum depth of form valley equal to two inches (50 millimeters). The forms shall have closed tapered ends. Lightweight filler material shall be used in the form valleys.

The metal forms shall be designed on the basis of dead load of the form, reinforcement and the plastic concrete, including the additional weight of concrete due to the deflection of the metal forms, plus 50 pounds per square foot (2.40 kilopascals) for construction loads. The allowable stress in the corrugated form and the accessories shall not be greater than 0.725 times the yield strength of the furnished material and the allowable stress shall not exceed 36,000 psi (250 megapascal). The span for design and deflection shall be the clear distance between edges of the beams or girders less two inches (50 millimeters) and shall be measured parallel to the form flutes. Maximum deflection of the forms under the weight of the plastic concrete, reinforcement, and forms shall not exceed 1/180 of the form span or 0.5 inches (13 millimeters), whichever is less. The permissible form camber shall be based on the actual dead load condition. Camber shall not be used to compensate for deflection in excess of the foregoing limits.

Form support angles shall be designed as a cantilever. The horizontal leg of the form's support angle shall not be greater than 3 inches (75 millimeters).

Before fabricating any material, the Contractor shall submit working drawings to the Engineer for review in accordance with Article 1.05.02-2, Working Drawings. These drawings shall include the proposed method of form construction, erection plans including weld procedure(s), material lists, material designation, gage of all materials, and the details of corrugation. Also, copies of the form design computations shall be submitted with the working drawings.

Form supports shall be used and no stay-in-place metal forms shall be placed over or be directly supported by the top flanges of beams or girders. The form supports may be supported by or be attached to the top flanges. Stay-in-place metal forms shall not be used in bays where longitudinal slab construction joints are located. Stay-in-place metal forms shall not be used under cantilevered slabs such as the overhang outside of fascia members.

Welding to the top flanges of steel beams and girders is not allowed in the areas where the top flanges are in tension, or as indicated on the plans. Alternate installation procedures shall be submitted addressing this condition.

Drilling of holes in prestressed concrete beams or the use of power-actuated tools on the prestressed concrete beams for fastening of the form supports to the prestressed concrete beams will not be permitted. No welding will be permitted on the reinforcing steel in the prestressed units.

All edges of openings cut for drains, pipes, and similar appurtenances shall be independently supported around the entire periphery of the opening.

All fabricated stay-in-place metal forms shall be unloaded, stored, and handled in such a manner as to preclude damage to the forms. Damaged material shall be replaced at no additional cost. Any exposed form or form support metal where the galvanized coating has been damaged, shall be thoroughly cleaned, wire brushed, then coated with two coats of a zinc dust-zinc oxide primer, FS No. TT-P-641d, Type II, as directed by the Engineer.

All fabricated stay-in-place metal forms shall be stored at the project site at least four inches (100 millimeters) above the ground on platforms, skids or other suitable supports and shall be protected against corrosion and damage.

Forms shall be installed from the topside in accordance with the manufacturer's placing plans, recommended details, and printed instructions. Forms shall be constructed to the lines, grades, shapes, and dimensions shown on the plans, unless otherwise directed by the Engineer. Form supports shall ensure that forms retain their correct dimensions and positions during use at all times. Form supports shall provide vertical adjustment to maintain design slab thickness at the crest of corrugation, to compensate for variations in camber of beams and girders, and to allow for deflections.

Field cutting of form sheet metal shall be made by a steel cutting saw. Supports, closures and cut-outs shall be cut with shears or saw. No flame cutting will be permitted.

All welding shall be accomplished by Connecticut certified welders in accordance with Subarticle 6.03.03 – 6, Welding.

The steel form supports shall be placed in direct contact with the flange of stringer or floor beam flanges and attached by bolts, clips, welding where permitted, or other approved means. Form sheets shall not be permitted to rest directly on the top of the stringer or floor beam flanges. Forms shall be securely fastened to form supports with self-drilling fasteners and shall have a minimum bearing length of one inch (25 millimeters) at each end.

In the areas where the form sheets lap, the form sheets shall be securely fastened to one another by fasteners at a maximum spacing of eighteen inches (450 millimeters). The ends of the form sheets shall be securely attached to the support angles with fasteners at a maximum spacing of eighteen inches (450 millimeters) or two corrugation widths, whichever is less. Welding of forms to supports is not allowed.

The depth of the concrete slab shall be as shown on the plans and the corrugated forms shall be placed so that the top of the corrugation will coincide with the bottom of the deck slab. No part of the forms or their supports shall protrude into the slab. All reinforcement in the bottom reinforcement mat shall have a minimum concrete cover of one inch (25 millimeters) unless noted otherwise on the plans.

The completed stay-in-place metal form system shall be sufficiently tight to prevent leakage of mortar or concrete.

Where forms or their installation are unsatisfactory in the opinion of the Engineer, either before or during placement of the concrete, the Contractor shall correct the defects before proceeding with the construction work. The cost of such corrective work shall be at the sole expense of the Contractor.

There will be no direct payment for the cost of the forms and form supports, or any material, tools, equipment, or labor incidental thereto, but the cost shall be considered included in the contract unit price per cubic yard (cu. m) for “Class ‘F’ Concrete”.

Article 6.01.03-8. Placing Concrete:

Add the following new paragraph after the first paragraph:

“The temperature of the concrete at the time of placement shall not be less than 60° F (15.5° C) or greater than 90° F (32° C). For pumped concrete, the temperature shall be determined at the placement end of the pump line. The temperature of the concrete shall be determined in accordance with ASTM C1064.”

Subarticle 6.01.03 – 9, Concrete for Bridge Decks:

Add the following:

Screed and runway supports shall not be located on any stay-in-place metal form sheets, form supports or reinforcing steel.

Concrete shall not be placed on the forms to a depth greater than twelve inches (300 millimeters) above the top of the forms. Concrete shall not be dropped more than three feet (1 meter) above the top of the forms, beams or girders.

**CONNECTICUT
SUPPLEMENTAL SPECIFICATION
SECTION 6.03
STRUCTURAL STEEL**

Delete the entire section and replace it with the following:

**SECTION 6.03
STRUCTURAL STEEL**

Description: Work under this item shall consist of furnishing, fabricating, transporting, storing, handling and erecting of structural steel of the type and size designated, as shown on the plans, as directed by the Engineer and in accordance with these specifications.

All work except as stated in the following paragraph shall conform to the requirements of the AASHTO LRFD Bridge Construction Specifications and the ANSI/AASHTO/AWS D1.5 – Bridge Welding Code.

All work subject to railroad loading shall conform to AREMA and the ANSI/AASHTO/AWS D1.5 – Bridge Welding Code.

Materials: The materials for this work shall conform to the requirements of Section M.06.

Materials for this work shall be stored off the ground before, during, and after fabrication. It shall be kept free from dirt, grease and other contaminants and shall be reasonably protected from corrosion. In addition, weathering steel shall be stored as to allow free drainage and promote the development of the oxide coating and a uniform appearance.

Construction Methods:

1. Pre-qualification:

(a) Fabricators producing material for Department projects under this item are required to have as a minimum, an active AISC Certification for Simple Steel Bridges. For fabrication of material for use on bridges other than un-spliced rolled beam bridges, AISC Major Steel Bridge Certification is required. If so noted on the plans, additional AISC endorsement for fabrication of fracture critical members is also required.

(b) Field Welders: Prior to working on material for Department projects under this specification, all field welders, field welding operators, and field tackers must possess a valid welder certification card issued by the Department's Division of Materials Testing. If such person has not been engaged in welding operations on a Department project or

project acceptable to the Department within a period of six months, or if he cannot produce an approved welding certificate dated within the previous twelve months from a welding agency acceptable to the Engineer, he shall be required to re-qualify through examination. The Engineer may require re-qualification of anyone whose quality of work he questions.

2. Submittals:

(a) Shop Drawings: Prior to any fabrication, the Contractor shall submit shop drawings in accordance with Article 1.05.02-3 to the Engineer for review and approval. Shop drawings shall include a cambering procedure and diagram. In the case of trusses, the Contractor is responsible for calculation of the camber (lengthening and shortening) of all truss members.

(b) Shop Schedule: The Contractor shall submit a detailed shop fabrication schedule to the Engineer for review within 30 days of the notice to proceed unless otherwise agreed to by the Engineer. At a minimum the schedule shall include the start date, milestone dates, and completion date. Any significant changes shall be brought to the attention of the Engineer immediately.

(c) Welding Procedures: Prior to start of fabrication, all weld procedures shall be submitted to the Engineer for review and approval.

(d) Working Drawings for Falsework and Erection of Structural Steel: Prior to erecting any steel fabricated under this specification, the Contractor shall submit drawings and supporting calculations, including erection stresses, in accordance with Article 1.05.02-2 to the Engineer. The design of temporary supports and falsework shall conform to the *AASHTO Specifications*, the *AASHTO Guide Design Specifications for Bridge Temporary Works* or any other standard acceptable to the Engineer. Falsework shall be of sufficient rigidity and strength to safely support all loads imposed and to produce in the finished structure the lines and grades indicated in the contract documents. The submittal shall include at a minimum:

- Title block with contract number, project identification number (PIN), town, and structure number and name.
- Plan of the work area showing support structures, roads, railroad tracks, Federal and State regulated areas as depicted on the plans, utilities or any other information relative to erection.
- A detailed narrative describing the erection sequence for main members and secondary members (cross frames, diaphragms, lateral bracing, portals, etc.), noting use of holding cranes or temporary supports, falsework, or bents.
- Delivery location of each girder.
- Location of each crane for each pick.
- Capacity chart for each crane and boom length used in the work.
- The capacity of the crane and of all lifting and connecting devices shall be adequate for the total pick load including spreaders and other materials. In the area of railroads and navigable waterways, the capacity shall be as required by Amtrak, Metro North, U.S. Coast Guard or other regulatory authorities. No picks shall be

allowed over vehicular or pedestrian traffic unless otherwise noted on the plans or permitted by the Engineer.

- Pick point location(s) on each member.
- Lifting weight of each member (including clamps, spreader beams, etc.)
- Lift and setting radius for each pick (or maximum lift radius).
- Description of lifting devices or other connecting equipment.
- Girder tie-down details or other method of stabilizing erected girders.
- Bolting requirements, including the minimum number of bolts and erection pins required to stabilize members during the erection sequence.
- Blocking details for stabilizing members supported on expansion bearings and on bearings that do not limit movement in the transverse direction.
- The method and location for temporary supports for field spliced or curved girders, including shoring, false work, holding cranes, guys, etc. The Engineer will review, but not approve details of temporary supports. The design, erection, and stability of these supports shall be the sole responsibility of the Contractor.
- Offsets necessary to adjust expansion bearings during erection to provide for temperature variance and dead load rotation.

The following notes shall be placed on the Erection Drawings:

- Cranes shall be operated in accordance with the Connecticut Department of Public Safety regulations.
- The Contractor shall be responsible for verifying the weight of each lift and for insuring the stability of each member during all phases of erection.
- Members shall be subject to only light drifting to align holes. Any drifting that results in distortion of the member or damage to the holes will be cause for rejection of the member.
- Field reaming of holes shall not be performed unless required by the Contract Drawing or approved by the Engineer.

The Contractor shall submit these documents to the Engineer at least 60 calendar days in advance of their proposed use. If the proposed method of erection requires additional members or modifications to the existing members of the structure, such additions and modifications shall be made by the Contractor at no expense to the State.

3. Shop Fabrication: Unless otherwise shown on the plans or indicated in the Special Provisions, Structural Steel shall be fabricated in accordance with the AASHTO LRFD Bridge Construction Specifications, amended as follows:

(a) Notification: The Contractor shall submit written notification to both the Engineer and the Director of Research and Materials Testing not less than 30 calendar days prior to start of fabrication. No material shall be manufactured or worked in the shop before the Engineer has been so notified. The notification shall include the name and location of the fabrication shop where the work will be done so that arrangements can be made for an audit of the facility and the assignment of a Department Quality Assurance inspector.

(b) Camber: All members shall be cambered prior to heat curving and painting. Rolled beams shall be heat cambered by methods approved by the Engineer. Plate girders shall be cambered by cutting the web to the prescribed shape with allowances for shrinkage due to cutting, welding, and heat curving. The fabricator is responsible to determine what allowances should be made. Rolled, plate-rolled, or fabricated sections shall be cambered to the total amount shown on the plans and within the camber deviation tolerances permitted for welded beams and girders, as indicated in the ANSI/AASHTO/AWS D1.5 Bridge Welding Code. The Contractor must submit to the Engineer for approval, a plan for corrective action if the actual camber is not within tolerance.

(c) Welding: Unless otherwise indicated on the plans or specifications, all work shall be performed in accordance with ANSI/AASHTO/AWS D1.5 – Bridge Welding Code.

(d) Preassembly of Field Connections: Field connections of main members of continuous beams, plate girders, bents, towers, rigid frames, trusses and arches shall be preassembled prior to erection as necessary to verify the geometry of the completed structure or unit and to verify or prepare field splices. The Contractor shall propose an appropriate method of preassembly for review and comment by the Engineer. The method and details of preassembly shall be consistent with the erection procedures shown on the working drawings and camber diagrams. As a minimum, the preassembly procedure shall consist of assembling three contiguous panels accurately adjusted for line and camber. Successive assemblies shall consist of at least one section or panel of the previous assembly plus two or more sections or panels added at the advancing end. In the case of structures longer than 150 feet (45 meters), each assembly shall not be less than 150 feet (45 meters) long regardless of the length of individual continuous panels or section. All falsework, tools, machinery and appliances, including drift pins and bolts necessary for the expeditious handling of the work shall be provided by the Contractor at no cost to the State.

(e) Inspection: The Contractor shall furnish facilities for the inspection of material and workmanship in the shop by the Engineer. The Engineer and his representative shall be allowed free access to the necessary parts of the premises.

The Engineer will provide Quality Assurance (QA) inspection at the fabrication shop to assure that all applicable Quality Control plans and inspections are adequately adhered to and maintained by the Contractor during all phases of the fabrication. A thorough inspection of a random selection of elements at the fabrication shop may serve as the basis of this assurance.

Prior to shipment to the project, each individual piece of structural steel shall be stamped or marked in a clear and permanent fashion by a representative of the fabricators' Quality Control (QC) Department to indicate complete final inspection by the fabricator and conformance to the project specifications for that piece. The stamp or mark must be dated. A Materials Certificate in accordance with Article 1.06.07 may be used in lieu of individual stamps or markings, for all material in a single shipment. The Materials Certificate must list each piece within the shipment and accompany the shipment to the project site.

Following the final inspection by the fabricator's QC personnel, the Engineer may select pieces of structural steel for re-inspection by the Department's QA inspector. Should non-conforming pieces be identified, all similar pieces must be re-inspected by the fabricator and repair procedure(s) submitted to the Engineer for approval. Repairs will be made at the Contractor's expense.

The pieces selected for re-inspection and found to be in conformance, or adequately repaired pieces, may be stamped or marked by the QA inspector. Such markings indicate the Engineer takes no exception to the pieces being sent to the project site. Such marking does not indicate acceptance or approval of the material by the Engineer.

Following delivery to the project site, the Engineer will perform a visual inspection of all material to verify shipping documents, fabricator markings, and that there was no damage to the material or coatings during transportation and handling.

The Engineer is not responsible for approving or accepting any fabricated materials prior to final erection and assembly at the project site.

(f) Nondestructive Testing: All nondestructive testing of structural steel and welding shall be performed as designated on the plans and in the project specifications. Such testing shall be performed by personnel approved by the Engineer.

Personnel performing Radiographic, Ultrasonic or Magnetic Particle testing shall be certified as a NDT Level II technician in accordance with the American Society for Non Destructive Testing (ASNT), Recommended Practice SNT-TC-1A.

Nondestructive testing shall be performed in accordance with the procedures and standards set forth in the AASHTO/AWS D1.5, Bridge Welding Code. The Department reserves the right to perform additional testing as determined by the Engineer.

All nondestructive testing shall be witnessed by an authorized representative of the Department. Certified reports of all tests shall be submitted to the Materials Testing Division for examination. Each certified report shall identify the structure, member, and location of weld or welds tested. Each report shall also list the length and location of any defective welds and include information on the corrective action taken and results of all retests of repaired welds.

Should the Engineer require nondestructive testing on welds not designated in the contract, the cost of such inspection shall be borne by the Contractor if the testing indicates that any weld is defective. If the testing indicates the weld to be satisfactory, the actual cost of such inspection will be paid by the Department.

(g) Marking: Each member shall be identified with an erection mark corresponding with the member identification mark on the approved shop drawings. Identification marks shall be impressed into the member with a low stress stamp in a location in accordance with standard industry practice.

(h) Shipping, Handling, Storage and Receiving: The Contractor shall make all arrangements necessary to properly load, transport, unload, handle and store all material. The Contractor shall furnish to the Engineer copies of all shipping statements. The weight (mass) of the individual members shall be shown on the statements. Members having a weight (mass) of more than 3 tons (2700 kilograms) shall have the weight (mass) marked thereon. All material shall be unloaded promptly upon delivery. The Contractor shall be responsible for any demurrage charges. Damage to any material during transportation, improper storage, faulty erection, or undocumented fabrication errors may be cause for rejection of said material at the project site. Top lateral bracing should be installed in tub girders prior to shipping and erection of the field pieces. All costs associated with any corrective action will be borne by the Contractor.

4. Field Erection: A meeting shall be held on site prior to any erection of structural steel. The Contractor shall name the person responsible for the steel erection work and provide copies of all crane operator licenses. Proposed equipment, rigging, timetable and methods shall be proposed at this meeting.

(a) Falsework: Any temporary work shall be constructed in conformance with the working drawings. The Contractor shall verify that the quality of materials and work employed are consistent with their design.

All girders shall be stabilized with falsework, temporary braces, or holding cranes until a sufficient number of adjacent girders are erected with all diaphragms and cross frames connected to provide necessary lateral support as shown in the erecting diagrams.

Adjustment shall be provided in the falsework and other temporary supports so that the temporary elevation of the structural steel provided by the falsework is consistent with the deflections that will occur as the structure is completed. The elevation of falsework shall be such as to support the girders at the cambered no-load elevation. Unloading of temporary supports should be performed such that all temporary supports at each cross section are unloaded uniformly. Unless specifically permitted by the Engineer, welding of falsework support brackets to structural steel is not allowed.

Unless erected by the cantilever method, truss spans shall be erected on blocking. The blocking shall be left in place until the tension chord splices are fully bolted and all other truss connections pinned and bolted and the proper geometric shape is achieved.

(b) Anchorages: Anchor bolts and similar materials which are to be placed during the erection of the structural steel shall be carefully and accurately set to the requirements of Article 6.01.03.

(c) Bearings: Bearing plates shall have a full and uniform bearing upon the substructure masonry. Bearing plates shall be placed upon bearing areas which are finished according to the requirements of Article 6.01.03.

Prefabricated pads conforming to the requirements of Article M-12.01 shall be installed unless specifically noted otherwise on the contract plans.

Each piece shall be the same size as the bearing plate it is to support and the holes to accommodate the anchor bolts shall be clearly and accurately punched before setting the pad in place.

In placing expansion bearings, due consideration shall be given to the temperature at the time of erection and stage construction requirements. The nuts of anchor bolts at expansion bearings shall be adjusted to permit the free movement of the span.

(d) Field Assembly: Members and components shall be accurately assembled as shown on the plans and any match marks shall be followed. The material shall be carefully handled so that no components will be bent, broken or otherwise damaged.

Hammering which will injure or distort the members is not permitted. Bearing surfaces and surfaces to be in permanent contact shall be cleaned before the members are assembled.

Cylindrical erection pins shall be 1/32 inch (0.8 mm) larger than the nominal diameter of the holes.

Splices and field connections of main stress carrying members shall be made with a minimum of 50% of the holes filled and tightened with high strength bolts before the lifting system is released. The bolts shall be installed uniformly throughout the connection. Lateral stability must be maintained until the deck is placed.

The Contractor shall ensure that girders are stable throughout the erection process. The stage of completeness of the bolted connections shall be considered when evaluating the strength and stability of the steel during erection. For Closed Box and Tub Girders the Contractor shall ensure that the cross- section shape of each box is maintained during erection. Top lateral bracing should be installed in tub girders prior to shipping and erection of the field pieces.

(e) Welded Connections:

Unless otherwise shown on the plans or indicated by the special provisions, welding of structural steel shall be done in accordance with "ANSI/AASHTO/AWS D1.5 Bridge Welding Code."

The Contractor's welding and inspection procedures for each type of field weld and field tacking must be submitted to the Engineer on the form designated by the Department. All procedures must be approved by the Materials Testing Division prior to any work and must be adhered to at all times.

Quality control is the responsibility of the Contractor. The Contractor must provide an AWS Certified Welding Inspector (CWI) in accordance with AWS D1.5. The CWI must be qualified and certified in accordance with the provisions of AWS QC1, *Standard for Qualification and Certification of Welding Inspectors*.

The CWI shall make visual inspection of all welds. The Contractor will perform magnetic particle inspection, ultrasonic testing inspection, or radiographic testing inspection of field welds when required on the plans or special provisions. Each test may be witnessed by an authorized representative of the Engineer.

Welds or sections of welds containing imperfections determined to be unacceptable by either the CWI or the Engineer shall be removed and re-welded by the Contractor at their expense. Welds so removed and replaced shall be re-inspected by the CWI. All costs for re-inspection or testing of such welds shall be borne by the Contractor.

(f) High Strength Bolted Connections:

The assembly of structural connections using ASTM A 325/ A 325M or ASTM A 490/A 490M high-strength bolts shall be installed so as to develop the minimum required bolt tension specified in Table A. The Manufacturer's certified test report; including the rotational capacity test results **must** accompany the fastener assemblies. Fastener Assemblies delivered without the certified reports will be rejected.

Bolts, nuts and washers from each rotational-capacity lot shall be shipped in the same container. If there is only one production lot number for each size of nut and washer, the nuts and washers may be shipped in separate containers. Each container shall be permanently marked with the rotational-capacity lot number such that identification will be possible at any stage prior to installation. Assemblies of bolts, nuts and washers shall be installed from the same rotational-capacity lot. Pins, small parts and packages of bolts, washers, and nuts shall be shipped in boxes, crates, kegs, or barrels. A list and description of the contained materials shall be plainly marked on the outside of each shipping container.

Bolted Parts: All material within the grip of the bolt shall be steel; there shall be no compressible material, such as gaskets or insulation, within the grip. Bolted steel shall fit solidly together after the bolts are tensioned. The length of the bolts shall be such that the end of the bolt will be flush with or outside of the face of the nut when properly installed.

Surface Conditions: At the time of assembly, all connection surfaces, including surfaces adjacent to the bolt head and nut, shall be free of scale, except tight mill scale, and shall be free of dirt or other foreign material. Burrs that would prevent solid seating of the connected parts in the snug tight condition shall be removed.

Paint is permitted on the faying surface, including slip critical connections, only when shown on the plans. The faying surfaces of slip-critical connections shall meet the requirements of the following paragraphs, as applicable:

- Connections specified to have un-coated faying surfaces: any paint, including any inadvertent over spray, shall be excluded from areas closer than one bolt diameter, but not less than 1.0 in. (25 mm), from the edge of any hole and all areas within the bolt pattern.
- Connections specified to have painted faying surfaces: shall be blast cleaned and coated in accordance with Section 6.04, and shall not be assembled until the coating system has been properly cured.

- Connections specified to have galvanized faying surfaces: shall be hot-dip galvanized in accordance with ASTM A 123/A 123M, and shall subsequently be roughened by means of hand wire brushing. Power wire brushing is not permitted.

Installation: At the pre-erection meeting, the Contractor shall inform the Engineer of their planned method of tensioning high strength bolts. Acceptable methods are: Turn-of-Nut, Calibrated Wrench or Direct Tension Indicator.

Fastener Assemblies:

A "fastener assembly" is defined as a bolt, a nut, and a washer. Only complete fastener assemblies of appropriately assigned lot numbers shall be installed.

Fastener assemblies shall be stored in an area protected from dirt and moisture. Only as many fastener assemblies as are anticipated to be installed and tensioned during a work shift shall be taken from protected storage. Fastener assemblies not used shall be returned to protected storage at the end of the shift. Prior to installation, fastener assemblies shall not be cleaned of lubricant. Fastener assemblies which accumulate rust or dirt resulting from site conditions shall be cleaned, relubricated and tested for rotational-capacity prior to installation. All galvanized nuts shall be lubricated with a lubricant containing a visible dye. Plain bolts must be oily to the touch when delivered and installed. Lubricant shall be removed prior to painting.

All bolts shall have a hardened washer under the turned element (nut or bolt head). All hardened washers shall conform to the requirements of ASTM F 436/F 436M.

Where necessary, washers may be clipped on one side to a point not closer than $7/8$ of the bolt diameter from the center of the washer. Circular and beveled washers, when used adjacent to direct tension indicator washers shall not be clipped. Direct tension indicator washers shall not be clipped.

Bolt Tension Measuring Device: The Contractor shall provide a calibrated bolt tension measuring device (a Skidmore-Wilhelm calibrator (Skidmore) or other acceptable bolt tension indicating device) at all times when, and at all locations where high-strength fasteners are being installed and tensioned. The tension measuring device (Skidmore) shall be calibrated by an approved testing agency at least annually. The Skidmore shall be used to perform the rotational-capacity test of the fastener assemblies. The Skidmore will also be used to substantiate (1) the suitability of the fastener assembly to satisfy the requirements of Table A, including lubrication as required, (2) calibration of the installation wrenches, if applicable, and (3) the understanding and proper use by the contractor of the selected method of tensioning to be used.

Complete fastener assemblies shall be installed in properly aligned holes and then tensioned by the Turn-of-Nut, Calibrated Wrench or Direct Tension Indicator method to the minimum tension specified in Table A. Tensioning may be done by turning the bolt while the nut is prevented from rotating when it is impractical to turn the nut. Impact wrenches, if

used, shall be of adequate capacity and sufficiently supplied with air to perform the required tensioning of each bolt in approximately 10 seconds.

Bolts shall be installed in all holes of the connection and the connection brought to a snug condition. Snug is defined as having all the plies of the connection in firm contact. Snugging shall progress systematically from the most rigid part of the connection to the free edges. The bolts of the connection shall then be tightened in a similar manner as necessary until the connection is properly tensioned.

Nuts shall be located, whenever practical, on the side of the connection which will not be visible from the traveled way.

Unless otherwise approved by the Engineer fastener assemblies shall be brought to full tension immediately following snugging.

Fully tensioned fastener assemblies shall not be reused. Retightening previously tensioned bolts which may have been loosened by the tensioning of adjacent bolts shall not be considered as reuse.

Rotational-Capacity Tests: In addition to the certified test reports, on site Rotational-capacity tests may be required by the Engineer. This test shall be performed by the Contractor at the location where the fasteners are installed and tensioned. When performed in the field, the procedure shall conform to the requirements of ASTM A 325/ A 325M Appendix A-1.

Turn-of-Nut Installation Method:

At the start of the work, the Contractor shall demonstrate that the procedure used by the bolting crew to develop a snug condition and to control the turns from a snug condition develops the tension required in Table A. To verify their procedure, the Contractor shall test a representative sample of not less than three complete fastener assemblies of each diameter, length and grade to be used in the work. This shall be performed at the start of work using a Skidmore. Periodic retesting shall be performed when ordered by the Engineer.

After snugging the connection, the applicable amount of rotation specified in Table B shall be achieved. During the tensioning operation there shall be no rotation of the part not turned by the wrench. Tensioning shall progress systematically from the most rigid part of the connection to its free edges.

Calibrated Wrench Installation Method:

Calibrated wrench method may be used only when the installation wrenches are properly calibrated daily, or as determined by the Engineer. Standard torques determined from tables or from formulas which are assumed to relate torque to tension **shall not** be acceptable.

The Contractor shall demonstrate to the Engineer periodically that all equipment and wrenches are providing a torque which has been calibrated to produce the minimum tension specified in Table A. The installation procedures shall be verified periodically, as determined by the Engineer, for each bolt diameter, length and grade using the fastener assemblies that are being installed in the work. This verification testing shall be accomplished in a Skidmore by tensioning three complete fastener assemblies of each diameter, length and grade from those being installed with a hardened washer under the element turned.

When significant difference is noted in the surface condition of the bolts, threads, nuts or washers, as determined by the Engineer, wrenches shall be recalibrated. The Contractor shall verify during the installation of the assembled steel work that the wrench adjustment selected by the calibration does not produce a nut or bolt head rotation from snug greater than that permitted in Table B. If manual torque wrenches are used, nuts shall be turned in the tensioning direction when torque is measured.

When calibrated wrenches are used to install and tension bolts in a connection, bolts shall be installed with hardened washers under the element turned to tension the bolts. Once the connection has been snugged, the bolts shall be tensioned using the calibrated wrench. Tensioning shall progress systematically from the most rigid part of the connection to its free edges. A calibrated torque wrench shall be used to "touch up" previously tensioned bolts which may have been relaxed as a result of the subsequent tensioning of adjacent bolts until all bolts are tensioned to the prescribed amount.

Direct Tension Indicator Installation Method:

When Direct Tension Indicators (DTIs) meeting the requirements of Section M.06 are used with high-strength bolts to indicate bolt tension, they shall be subjected to the verification testing described below and installed in accordance with the method specified below. Unless otherwise approved by the Engineer, the DTIs shall be installed under the head of the bolt and the nut turned to tension the bolt. The Manufacturer's recommendations shall be followed for the proper orientation of the DTI and additional washers, if any, required for the correct use of the DTI. Installation of a DTI under the turned element may be permitted if a washer is used to separate the turned element from the DTI.

Verification: Verification testing shall be performed in a Skidmore. A special flat insert shall be used in place of the normal bolt head holding insert. Three verification tests shall be required for each combination of fastener assembly rotational-capacity lot, DTI lot, and DTI position relative to the turned element (bolt head or nut) to be used on the project. The fastener assembly shall be installed in the tension-measuring device with the DTI located in the same position as in the work. The element intended to be stationary (bolt or nut) shall be restrained from rotation.

The verification tests shall be conducted in two stages. The bolt nut and DTI assembly shall be installed in a manner so that at least three and preferably not more than five threads are located between the bearing face of the nut and the bolt head. The bolt shall be tensioned first to the load equal to that listed in Table C

under Verification Tension for the grade and diameter of the bolt. If an impact wrench is used, the tension developed using the impact wrench shall be no more than two-thirds of the required tension. Subsequently, a manual wrench shall be used to attain the required tension. The number of refusals of the 0.005-in. (0.125-mm) tapered feeler gage in the spaces between the protrusions shall be recorded. The number of refusals for uncoated DTIs under the stationary or turned element, or coated DTIs under the stationary element, shall not exceed the number listed under Maximum Verification Refusals in Table C for the grade and diameter of bolt used. The maximum number of verification refusals for coated DTIs (galvanized, painted, or epoxy-coated), when used under the turned element, shall be no more than the number of spaces on the DTI less one. The DTI lot shall be rejected if the number of refusals exceeds the values in the table or, for coated DTIs if the gage is refused in all spaces.

After the number of refusals is recorded at the verification load, the bolt shall be further tensioned until the 0.005-in (0.125-mm) feeler gage is refused at all the spaces and a visible gap exists in at least one space. The load at this condition shall be recorded and the bolt removed from the tension-measuring device. The nut shall be able to be run down by hand for the complete thread length of the bolt excluding thread run-out. If the nut cannot be run down for this thread length, the DTI lot shall be rejected unless the load recorded is less than 95 percent of the average load measured in the rotational capacity test of the fastener lot as specified previously in "Rotational-Capacity Tests."

If the bolt is too short to be tested in the calibration device, the DTI lot shall be verified on a long bolt in a calibrator to determine the number of refusals at the verification tension listed in Table C. The number of refusals shall not exceed the values listed under maximum verification refusals in Table C. Another DTI from the same lot shall then be verified with the short bolt in a convenient hole in the work. The bolt shall be tensioned until the 0.005-in. (0.125-mm) feeler gage is refused in all spaces and a visible gap exists in at least one space. The bolt shall then be removed from the tension-measuring device and the nut shall be able to be run down by hand for the complete thread length of the bolt excluding thread run-out. The DTI lot shall be rejected if the nut cannot be run down this thread length.

Installation: Installation of fastener assemblies using DTIs shall be performed in two stages. The stationary element shall be held against rotation during each stage of the installation. The connection shall be first snugged with bolts installed in all holes of the connection and tensioned sufficiently to bring all the plies of the connection into firm contact. The number of spaces in which a 0.005-in. (0.125-mm) feeler gage is refused in the DTI after snugging shall not exceed those listed under maximum verification refusals in Table C. If the number exceeds the values in the table, the fastener assembly shall be removed and another DTI installed and snugged.

For uncoated DTIs used under a stationary or turned element and for coated DTIs used under a stationary element, the bolts shall be further tensioned until the number of refusals of the 0.005-in. (0.125-mm) feeler gage shall be equal or greater than the number listed under Minimum Installation Refusals in Table C. If the bolt is

tensioned so that no visible gap in any space remains, the bolt and DTI shall be removed and replaced by a new properly tensioned bolt and DTI.

When coated DTIs (galvanized, painted or epoxy coated) are used under a turned element, the 0.005-in (0.125-mm) feeler gage shall be refused in all spaces.

Inspection:

The Contractor shall provide all the material, equipment, tools and labor necessary for the inspection of the bolted connections. Access to the bolted parts and fastener assemblies, both before and after the fasteners are installed and tensioned, shall be provided.

The Contractor is responsible for Quality Control (QC). The Contractor shall review this specification with its project personnel prior to performing the work. The Contractor shall verify the proper markings, surface conditions and storage of fastener assemblies. The Contractor shall inspect the faying surfaces of connections for compliance with the plans and specifications. The Contractor shall provide to the Engineer a copy of their written QC report for each shift of the calibration or verification testing specified. This report shall confirm that the selected procedure is properly used and that the fastener assemblies installed meet the tensions specified in Table A. The Contractor shall monitor the installation of fasteners in the work to assure that the selected procedure, as demonstrated in the initial testing to provide the specified tension, is routinely and properly applied.

The Contractor, in the presence of the Engineer, shall inspect the tensioned bolts using an inspection torque wrench, as defined below. If direct tension indicator devices are used, the appropriate feeler gauge will be used. Inspection tests shall be performed within 24 hours of bolt tensioning to prevent possible loss of lubrication or corrosion influence on tensioning torque.

The inspection torque wrench shall be calibrated as follows. Three bolts of the same grade, size, and condition as those under inspection shall be placed individually in a device calibrated to measure bolt tension. This calibration operation shall be done at least once each inspection day. There shall be a washer under the part turned in torquing each bolt. In the calibrated device, each bolt shall be tightened by any convenient means to the specified tension. The inspection wrench shall then be applied to the tensioned bolt to determine the torque required to turn the nut or head five degrees in the tightening direction. The average of the torque required for all three bolts shall be defined as the job-inspection torque.

Twenty-five percent, but a minimum of two, of the tensioned bolts shall be selected by the Engineer for inspection in each connection. (The Engineer may reduce the number of bolts tested at a connection to 10% based on the Contractor's past performance and splice location.) The job-inspection torque shall then be applied to each selected assembly with the inspection torque wrench turned in the tightening direction. If all inspected bolt heads or nuts do not turn, the bolts in the connection shall be considered to be properly tensioned. If the torque turns one or more bolt heads or nuts, the job-inspection torque shall then be applied to **all** bolts in the connection or to the satisfaction of the Engineer. Any bolt whose head or nut turns shall be re-tensioned and re-inspected. The Contractor

may, however, re-tension all the bolts in the connection with the inspection torque wrench and resubmit it for inspection, so long as the bolts are not over-tensioned or damaged by this action.

(g) Field Corrections and Misfits: Reaming of bolt holes during erection shall be permitted only with approval of the Engineer. No excessive forces shall be applied to any member to provide for proper alignment of the bolt holes.

The correction of minor misfits involving minor amounts of reaming, cutting, grinding and chipping shall be considered a legitimate part of the erection. However, any error in the shop fabrication or deformation resulting from handling and transportation may be cause for rejection. The Contractor shall be responsible for all misfits, errors and damage and shall make the necessary corrections and replacements.

TABLE A (Metric)
Minimum Bolt Tension in Kilonewtons*

Bolt Size	ASTM A 325M	ASTM A 490M
M16	91	114
M20	142	179
M22	176	221
M24	205	257
M27	267	334
M30	326	408
M36	475	595

*Equal to 70% of specified minimum tensile strength of bolts (as specified in ASTM Specifications for tests of full-size A 325M and A 490M bolts with metric coarse threads series ANSI B1.13M, loaded in axial tension) rounded to the nearest kilonewton.

Table A (English)
Minimum Bolt Tension in kips*

Bolt Size (Inches)	ASTM A 325	ASTM A 490
5/8	19	24
3/4	28	35
7/8	39	49
1	51	64
1 1/8	56	80
1 1/4	71	102
1 3/8	85	121
1 1/2	103	148

*Equal to 70% of specified minimum tensile strength of bolts (as specified in ASTM Specifications for tests of full-size A 325 and A 490 bolts with UNC threads, loaded in axial tension) rounded to the nearest kip.

**TABLE B (English and Metric)
Nut Rotation from the Snug Condition
Geometry^{a,b,c} of Outer Faces of Bolted Parts**

Bolt Length (measured from underside of head to end of bolt)	Both Faces Normal to Bolt Axis	One Face Normal to Bolt Axis and Other Face Sloped Not More Than 1:20, Bevel Washer Not Used	Both Faces Sloped Not More Than 1:20 From Normal to Bolt Axis, Bevel Washer Not Used
Up to and including 4 diameters	1/3 turn	1/2 turn	2/3 turn
Over 4 diameters but not exceeding 8 diameters	1/2 turn	2/3 turn	5/6 turn
Over 8 diameters but not exceeding 12 diameters	2/3 turn	5/6 turn	1 turn

(a) Nut rotation, as used in Table B, shall be taken as relative to the bolt, regardless of the element (nut or bolt) being turned. For bolts installed by 1/2 turn and less, the tolerance should be plus or minus 30 degrees; for bolts installed by 2/3 turn and more, the tolerance should be plus or minus 45 degrees.

To determine the nut rotation for installation and inspection of the fasteners, the nut and the end of the bolt or the head of the bolt and the adjacent steel shall be match marked.

(b) The values, given in Table B, shall be applicable only to connections in which all material within grip of the bolt is steel.

(c) No research work has been performed by the Research Council Riveted and Bolted Structural Joints to establish the turn-of-nut procedure when bolt lengths exceed 12 diameters. For situations in which the bolt length, measured from the underside of the head to the end of the bolt, exceeds 12 diameters, the required rotation shall be determined by actual tests in a suitable tension device simulating the actual conditions.

TABLE C (Metric)

Bolt Dia. (in.)	Verification Tension		Maximum Verification Refusals		DTI Spaces		Minimum Installation Refusals	
	A325	A490	Type 8.8	Type 10.9	Type 8.8	Type 10.9	Type 8.8	Type 10.9
M16	96	120	1	1	4	4	2	2
M20	149	188	2	2	5	6	3	3
M22	185	232	2	2	5	6	3	3
M24	215	270	2	2	5	6	3	3
M27	280	351	2	3	6	7	3	4
M30	342	428	3	3	7	8	4	4
M36	499	625	3	4	8	9	4	5

TABLE C (English)

Bolt Dia. (in.)	Verification Tension		Maximum Verification Refusals		DTI Spaces		Minimum Installation Refusals	
	A325	A490	325	490	325	490	325	490
5/8	20	25	1	2	4	5	2	3
¾	29	37	2	2	5	6	3	3
7/8	41	51	2	2	5	6	3	3
1	54	67	2	3	6	7	3	4
1 1/8	59	84	2	3	6	7	3	4
1¼	75	107	3	3	7	8	4	4
1 3/8	89	127	3	3	7	8	4	4
1½	108	155	3	4	8	9	4	5

Method of Measurement: Payment under this item will be at the contract lump sum price per each complete bridge structure or shall be based on the net weight (mass) of metal in the fabricated structure, whichever method appears on the proposal form.

When payment is based on a lump sum basis, the work, including anchor bolts, steel bearings and plates will not be measured for payment. Bearing plates welded to the girder are included in the price of the structural steel and bearing plates bonded to the bearings are included in the price of the bearing.

When payment is based on the net weight (mass) of metal in the fabricated structure, it shall be computed as described below.

The weight (mass) of the metal works to be paid for under the item of structural steel shall be computed on the basis of the net finished dimensions of the parts as shown on the shop drawings, deducting for copes, cuts, clips and all open holes, except bolt holes, and on the following basis:

1. The weights (masses) of rolled shapes shall be computed on the basis of their nominal weights (masses) per foot (meter), as shown in the shop drawings or listed in handbooks.

The weight (mass) of plates shall be computed on the basis of the nominal weight (mass) for their width and thickness as shown on the shop drawings.

2. The weight (mass) of temporary erection bolts, shop and field paint, galvanization, boxes, crates and other containers used for shipping, and materials used for supporting members during transportation and erection, shall not be included.

3. The weight (mass) of all high strength bolts, nuts, and washers shall be included on the basis of the following weights (masses):

Weight per 100			
Nominal diameter of H.S. bolt (inch)	Bolthead, nut, 1 washer and stickthrough (lbs)	Nominal diameter of H.S. bolt (mm)	Bolthead, nut, 1 washer and stickthrough (kg)
1/2	22	16	17
5/8	33	20	26
3/4	55	22	39
7/8	84	24	50
1	120	27	60
1 1/8	169	30	73
1 1/4	216	36	122

4. The weight (mass) of weld metal shall be computed on the basis of the theoretical volume from plan dimensions of the welds.

Size of fillet in Inches (mm)		Weight of weld in pounds per foot (kg per meter)	
3/16	(5)	0.08	(0.119)
1/4	(6)	0.14	(0.208)
5/16	(8)	0.22	(0.327)
3/8	(9.5)	0.30	(0.446)
1/2	(13)	0.55	(0.818)
5/8	(16)	0.80	(1.190)
3/4	(19)	1.10	(1.636)
7/8	(22)	1.50	(2.231)
1	(25)	2.00	(2.974)

5. The weight (mass) of steel shims, filler plates and anchor bolts shall be measured for payment.

When the pay item "Materials for Structural Steel (Site No.)" is included in the Contract, payment for furnishing of the raw steel material for the plates and shape material only, excluding any markup, based on the net weight (mass) required, and the payment will be made under the estimated item "Materials for Structural Steel (Site No.)". The overruns or wastage shall not exceed ten per cent for straight girders and fifteen per cent for curved girders. All other work specified in this section for the bridge will be deemed paid for under the lump sum price. In the absence of the pay item "Materials for Structural Steel (Site No.)", the cost of the raw material is included in the Lump Sum payment for this item, "Structural Steel (Site No.)".

Basis of Payment: The structural steel, incorporated in the completed and accepted structure, will be paid for at the contract lump sum price for "Structural Steel (Site No.)," or at the contract unit price per hundred weight (kilogram) for "Structural Steel," whichever is indicated in the contract documents.

Payment for either method shall be for structural steel, complete in place, which price shall include quality control, furnishing, fabricating, transporting, storing, erecting, welding, surface preparation and all materials including fastener assemblies, steel bearing assemblies and anchor bolts, equipment, tools and labor incidental thereto.

When the pay item "Materials for Structural Steel (Site No.)" is included in the Contract, payment for furnishing of the raw steel material for the plates and shape material only,

excluding any markup, based on the net weight (mass) required, and the payment will be made under the estimated item "Materials for Structural Steel (Site No.)". All remaining work including, but not limited to, preparation of shop drawings, fabricating, transporting, storage and handling, erecting, surface preparation and all materials, equipment, tools and labor incidental thereto, will be paid for under "Structural Steel (Site No.)".

In the absence of the pay item "Materials for Structural Steel (Site No.)", the cost of the raw material is included in the Lump Sum payment for this item, "Structural Steel (Site No.)". All remaining work including, but not limited to, preparation of shop drawings, fabricating, transporting, storage and handling, erecting, surface preparation and all materials, equipment, tools and labor incidental thereto, will be paid for under "Structural Steel (Site No.)".

No direct payment will be made for setting anchor bolts, preparing bearing areas, furnishing and placing materials under bearings. No direct payment will be made for non destructive testing as shown on the plans.

<u>Pay Item</u>	<u>Pay Unit</u>
Structural Steel (Site No.)	l.s. (l.s.)
Structural Steel	cwt. (kg)

**CONNECTICUT
SUPPLEMENTAL SPECIFICATION
SECTION 6.12
CONCRETE CYLINDER CURING BOX**

Delete the entire section and replace with it the following:

6.12.01 –Description: This item shall consist of furnishing a box for curing concrete test cylinders. The box shall be commercially available and manufactured specifically for curing concrete test cylinders. The box will remain the property of the Contractor at the conclusion of the project. The box shall be delivered to a location on the project as directed by the Engineer.

6.12.02 – Materials: A catalog cut listing detailed specifications of the box and operating instructions from the manufacturer must be submitted to the Engineer. The box and its components shall be constructed of non-corroding materials and shall be capable of storing a minimum of 18 test cylinders, 6" X 12" (152 mm X 305 mm) stored vertically with the lid closed. The lid must be watertight when closed and hinged in the back with security latches on the front that can be padlocked. The box must be capable of holding water to a maximum level of one inch above test cylinders placed in the box vertically. A drain hole must be provided in a wall of the box to allow manual drainage of the water that exceeds this level. A drain hole must also be provided at the bottom of the box so that it can be manually emptied. The temperature of the water must be controlled by heating and cooling device capable of maintaining the temperature of the water within a range of 60 to 80° F, +/- 2 °F (15.5 to 26.7 °C, +/- 1 °C) within an outside ambient air temperature range of -10 to 120 ° F (-23.3 to 49 °C). The heating and cooling device must be positioned to allow free circulation of air and water around the cylinders and be rated at 120 volts and 15 amps. A rack must be provided within the box to support the cylinders above the pool of temperature controlled water. The device must be thermostatically controlled with a digital readout that is capable of displaying the high/low water temperature within the box since the last reading was taken.

6.12.03 - Construction Methods: The Contractor shall maintain the curing box in working order and shall provide all necessary electrical service and water so that the curing box can be used properly during the entire course of the project. Any curing box that is not operating properly, as determined by the Engineer, shall be replaced within 24 hours by the Contractor at no expense to the State. The Engineer reserves the right to prohibit placement of fresh concrete on the project until a curing box acceptable to the Engineer is operational on the project site.

6.12.04 - Method of Measurement: The furnishing of the concrete test cylinder curing box will be measured for payment by the number of boxes delivered by the Contractor and accepted by the Engineer.

6.12.05 – Basis of Payment: This item will be paid for at the contract unit price each for “Concrete Cylinder Curing Box” ordered and accepted on the project, which price shall include all submittals, material, tools, equipment, and labor incidental thereto. The price shall also include all maintenance and operating costs related to the curing box for the duration of the project.

**CONNECTICUT
SUPPLEMENTAL SPECIFICATION
SECTION 6.51
CULVERTS**

6.51.02 – Materials:

In the 2nd paragraph replace “Gravel fill” with “Granular fill”.

6.51.03 – Construction Methods:

In the 8th paragraph replace “gravel fill” with “granular fill”.

Delete the 13th paragraph, “Bituminous fiber and ... as the pipe.”

6.51.04 – Methods of Measurement:

In the 7th paragraph replace “Gravel Fill” with “Granular Fill”.

6.51.05 – Basis of Payment:

In the 8th paragraph replace “Gravel Fill” with “Granular Fill”.

**CONNECTICUT
SUPPLEMENTAL SPECIFICATION
SECTION 7.02
PILES**

Article 7.02.05- Basis of Payment:

In the first sentence of the first paragraph of Section "2. Timber Piles" change "Furnishing Timber Piles Foot (Meter Length) and Furnishing Treated Timber Piles Foot (Meter Length)" to "Furnishing (Type) Timber Piles (Foot (Meter) Length)".

In the first sentence of the last paragraph of Section "2. Timber Piles" change "Driving Timber Piles" and "Driving Treated Timber Piles " to "Driving (Type) Timber Piles".

Under Pay Items:

Delete:

<u>Pay Item</u>	<u>Pay Unit</u>
Furnishing (Type) Piles (Lengths)	lb. (kg)

Add:

<u>Pay Item</u>	<u>Pay Unit</u>
Furnishing (Type) Timber Piles (Length)	ea. (ea)
Furnishing Steel Piles	lb. (kg)
Furnishing (Type) Prestressed Concrete Piles	l.f. (m)
Cast-in-Place Concrete Piles	l.f. (m)

**CONNECTICUT
SUPPLEMENTAL SPECIFICATION
SECTION 8.22
TEMPORARY PRECAST CONCRETE BARRIER CURB**

Article 8.22.04 – Method of Measurement:

Add the following sentence to the end of the second paragraph:

“Relocation of Temporary Precast Concrete Barrier Curb for access to the work area or for the convenience of the Contractor shall be considered incidental to Maintenance and Protection of Traffic and will not be measured for payment.”

**CONNECTICUT
SUPPLEMENTAL SPECIFICATION
SECTION 9.10
METAL BEAM RAIL**

Article 9.10.04 – Method of Measurement

Subarticle 1 – Metal Beam Rail (Type)

Delete the only sentence and replace with the following:

The length of metal beam rail measured for payment will be the number of linear feet (meters) of accepted rail of the type or designation installed, including radius rail other than Curved Guide Rail Treatment, measured along the top of rail between centers of end posts in each continuous section.

**CONNECTICUT
SUPPLEMENTAL SPECIFICATION
SECTION 9.18
THREE CABLE GUIDE RAILING
(I-BEAM POSTS) AND ANCHORAGES**

9.18.03 – Construction Methods:

In the 10th paragraph, replace “MIL” with “MILSPEC.”

**CONNECTICUT
SUPPLEMENTAL SPECIFICATION
SECTION 9.22
BITUMINOUS CONCRETE SIDEWALK
BITUMINOUS CONCRETE DRIVEWAY**

9.22.03 – Construction Methods:

Replace the first paragraph with the following:

“1. Excavation: Excavation, including saw cutting, removal of any existing sidewalk, or driveway, shall be made to the required depth below the finished grade, as shown on the plans or as directed by the Engineer. All soft and yielding material shall be removed and replaced with suitable material.”

9.22.05 – Basis of Payment:

Replace the only paragraph with the following:

“This work will be paid for at the contract unit price per square yard (square meter) for "Bituminous Concrete Sidewalk" or "Bituminous Concrete Driveway," as the case may be, complete in place, which price shall include all saw cutting, excavation as specified above, backfill, disposal of surplus material, gravel or reclaimed miscellaneous aggregate base, and all equipment, tools, labor and materials incidental thereto.”

**CONNECTICUT
SUPPLEMENTAL SPECIFICATION
SECTION 9.44
TOPSOIL**

Add the following paragraph to the beginning of article 9.44.03 – Construction Methods:

“The Contractor shall notify the Engineer of the location of the topsoil at least 15 calendar days prior to delivery. The topsoil and its source shall be inspected and approved by the Engineer before the material is delivered to the project. Any material delivered to the project, which does not meet specifications or which has become mixed with undue amounts of subsoil during any operation at the source or during placing and spreading, will be rejected and shall be replaced by the Contractor with acceptable material.”

**CONNECTICUT
SUPPLEMENTAL SPECIFICATION
SECTION 9.49
FURNISHING, PLANTING and MULCHING
TREES, SHRUBS, VINES and GROUND COVER PLANTS**

9.49.03 – Construction Methods:

Replace subsection 5. Pits with the following:

“5. Pits: The pit diameters shall be twice the diameter of the root-spread or container diameters, and shall be 2- inches (50 millimeters) less than the height of the rootball measured from the bottom of the ball to the root collar. (i. e. A 12-inch (300 millimeters) measurement between the root collar and the bottom of the rootball will require a 10-inch (250 millimeters) deep pit). Any excavation in excess of that required shall be replaced with planting soil and compacted to the satisfaction of the Engineer.”

Add the following sentence to subsection 6. Obstructions Below Ground:

“If removal of obstructions results in a deeper hole than needed for planting, backfill material shall be added and compacted to the satisfaction of the Engineer.”

Replace subsection 7. Preparation of Backfill with the following:

“**7. Backfill:** Backfill shall conform to M.13.01-1 Planting Soil.”

Replace subsection 8. Setting Plants with the following:

“**8. Setting Plants:** All plants shall be plumb and at a level that is 2-inches (50 millimeters) higher than the surrounding ground. Backfill material for all plants shall be thoroughly and properly settled by firming or tamping. Thorough watering shall accompany backfilling. Saucers capable of holding water shall be formed at individual plants (exclusive of plant beds) by placing ridges of planting soil around each, or as directed by the Engineer.

a. Balled and Burlapped plants: Plants shall be handled in such manner so that the soil will not be loosened from the roots inside of the ball. Carefully place the plant into the prepared pits and backfill with planting soil to one - half the depth of the pit, thoroughly tamp to the satisfaction of the Engineer around the ball. Fill the remaining area of the pit with water. Once water has completely drained, loosen the burlap and peel down the top one third. If wire baskets are used, cut and bend down the top third of the basket. Roots that have been wrapped around the ball within the burlap shall be straightened and the remainder of the pit filled with planting soil tamped to ensure that no air pockets remain.

b. Container Grown Plants: Carefully remove the plant from the container over the prepared pits. Gently loosen the soil and straighten all roots as naturally as possible. Place into the bottom of the pit. Backfill with planting soil to one - half the depth of the pit. Thoroughly tamp to the satisfaction of the Engineer. Fill remaining area of the pit with water. Once water has completely drained fill the remainder of the pit with planting soil tamped to ensure that no air pockets remain.

c. Bare-roots Plants: Carefully spread roots as naturally as possible and place into the bottom of the pit. All broken or frayed roots shall be cleanly cut off. Backfill with planting soil to one - half the depth of the pit. Thoroughly tamp to the satisfaction of the Engineer. Fill remaining area of the pit with water. Once water has completely drained fill the remainder of the pit with planting soil tamped to ensure that no air pockets remain.”

Replace subsection 10. Watering with the following:

“10. Watering: All plants shall be watered upon setting and as many times thereafter as conditions warrant.

The following is a guide for minimum requirements:

Trees:

2 ½” Caliper and less – Fifteen (15) gallons each.

3” to 5” Caliper – Twenty (20) gallon each.

5 ½” Caliper and above – Twenty-five (25) gallon each.

Shrubs:

24” and less – Six (6) gallon each.

More than 24”- Ten (10) gallon each.

Vines, Perennials, and Ornamental Grasses – Three (3) gallons each.

Groundcovers and Bulbs – Two (2) gallons per square foot.

Water shall be applied at a controlled rate and in such a manner to ensure that the water reaches the root zone (saucer) of the plant or plant bed and does not run off to adjacent areas. Watering shall be applied in a manner that does not dislodge plants, erode soil or mulch, or cause damage to saucer.

The Contractor may use slow-release, drip irrigation bags for watering in accordance with manufacturer’s instructions. The use of these portable/temporary irrigation bags will require the approval of the Engineer.

Overhead hydro-seeder spray nozzles shall not be used as watering devices.”

Replace subsection 17. Establishment Period with the following:

“17. One-Year Establishment Period: All plant material shall be subject to a One-Year Establishment Period. During this time, the Contractor shall use currently accepted horticultural practices to keep all plant material installed in a healthy, vigorous growing condition at the date of final acceptance. The date of final

acceptance shall be one full calendar year following the satisfactory completion of the planting activities as confirmed by the Engineer.

An inspection will be held one year from the date of installation with the Contractor, Engineer, and Landscape Designer to determine the acceptability of the plant establishment. An inventory of losses and rejected materials will be made and corrective and necessary clean up measures will be determined at the plant inspection.”

**CONNECTICUT
SUPPLEMENTAL SPECIFICATION
SECTION 9.75
MOBILIZATION**

9.75.04 – Method of Measurement:

Delete the entire section and replace with the following:

This work will be measured for payment in the manner described hereinafter; however, the determination of the total contract price earned shall not include the amount of mobilization earned during the period covered by the current monthly estimate- but shall include amounts previously earned and certified for payment:

1. When the first payment estimate is made, 25 percent of the lump sum bid price for this item or 2.5 percent of the total original contract price, whichever is less, shall be certified for payment.
2. When the Baseline Schedule, as specified under Section 1.05.08, is accepted, 50 percent of the lump sum bid price or 5 percent of the total original contract price, whichever is less, minus any previous payments, will be certified for payment.
3. When 10 percent of the total original contract price is earned and the Baseline Schedule, as specified under Section 1.05.08, is accepted, 75 percent of the lump sum price of this item or 7.5 percent of the total original contract price, whichever is less, minus any previous payments, will be certified for payment.
4. When 30 percent of the total original contract price is earned and the Baseline Schedule, as specified under Section 1.05.08, is accepted, 100 percent of the lump sum price of this item or 10 percent of the total original contract price, whichever is less, minus any previous payments, will be certified for payment.

Upon completion of all work on the project, payment of any amount bid for mobilization in excess of 10 percent of the original contract amount will be paid.

Nothing herein shall be construed to limit or preclude partial payments otherwise provided for by the contract.

**CONNECTICUT
SUPPLEMENTAL SPECIFICATION
SECTION 10.01
TRENCHING AND BACKFILLING**

Article 10.01.01- Description:

In the only sentence of the first paragraph after "...satisfactory..." add the following: "clean-up and".

In the only sentence of the second paragraph after "...reconstruction of..." add the following: "bituminous, concrete and granite curbing,".

Article 10.01.05- Basis of Payment:

In the only sentence of the second paragraph after "...mulching..." add the following: "clean-up and". After "...installing..." add the word "curbing,".

At the end of the third paragraph, add the following: "In the absence of a "Rock in Trench Excavation" item, the work will be compensated as extra work."

In the only sentence of the sixth paragraph, after ..."...unit price for 'Concrete Sidewalk'..." add the following: "or as extra work, if no unit price has been established."

**CONNECTICUT
SUPPLEMENTAL SPECIFICATION
SECTION 10.10
CONCRETE HANDHOLE**

Article 10.10.05 – Basis of Payment

Remove the words “ground wire”.

At the end of the paragraph add the following sentence:

The ground wire (bonding wire) is included in the Contract unit price under Section 10.08 – Electrical Conduit.

Add the word “Cover” to the end of the pay item “Cast Iron Handhole”

**CONNECTICUT
SUPPLEMENTAL SPECIFICATION
SECTION 11.13
CONTROL CABLE**

11.13.03 – Construction Methods:

In the 1st paragraph of subsection 2 replace "MIL" with "MILSPEC."

**CONNECTICUT
SUPPLEMENTAL SPECIFICATION
SECTION 12.10
EPOXY RESIN PAVEMENT MARKINGS, SYMBOLS AND LEGENDS**

12.10.03 (2) – Procedures:

Insert the following after the sixth paragraph:

The epoxy shall be uniformly applied to the surface to be marked to ensure a wet film thickness of the applied epoxy, without glass beads, of 20 mils +/- 1 mil (500 um +/- 25 um).

**CONNECTICUT
SUPPLEMENTAL SPECIFICATION
SECTION M.06
METALS**

Article M.06.01 – Reinforcing Steel:**Subarticle 1. Bar Reinforcement:**

Delete the third paragraph and replace it with:

“Epoxy coated bar reinforcement shall conform to the requirements of ASTM A 615/A 615M, Grade 60 (420) and shall be epoxy coated to the requirements of ASTM A 775/A 775M. All field repairs of the epoxy coating shall conform to the requirements of ASTM D 3963/D 3963M.”

Article M.06.02—Structural Steel and Other Structural Materials:

Delete the entire article and replace it with the following:

Article M.06.02—Structural Steel: The materials for this work shall conform to the following requirements:

1. Structural Steel:

Structural steel for bridges shall conform to the designation shown on the plans. Unless otherwise indicated in the plans or specifications, structural steel for non-bridge related members or components shall conform to ASTM A709/A709M, Grade 36 (250).

All surfaces of steel plates and shapes used in the fabrication of bridge girders shall be blast cleaned and visually inspected by the Contractor prior to any fabrication or preparation for fabrication. Blast cleaning shall conform to the requirements of SSPC-SP-6-Commercial Blast.

All steel plates and shapes used in the fabrication of bridge girders shall be substantially free from pitting and gouges, regardless of the cause. Substantially free is defined as:

- The measured surface area of all pits and gouges regardless of depth represent less than 1% of the surface area of the plate or shape.
- No pit or gouge greater than 1/32 (0.08mm) inch deep.
- No pit or gouge closer than six inches (15.25 cm) from another.

Any repair of plates or shapes will be performed in accordance with ASTM A6/A 6M.

2. Anchor Bolts:

Unless otherwise designated on the plans, anchor bolts, including suitable nuts and washers, shall conform to the following requirements:

Anchor bolt assemblies shall conform to the requirements of ASTM F1554, Grade 36 (250). All components of the bolt assembly shall be galvanized in conformance with ASTM A 153/A 153M.

Certified Test Reports and Material Samples: The Contractor shall submit notarized copies of Certified Test Reports in conformance with Article 1.06.07. Prior to incorporation into the work, the Contractor shall submit samples of the anchor bolt assemblies to the Engineer for testing in accordance with the latest edition of the "Schedule of Minimum Requirements for Acceptance Testing". One sample shall be submitted for each diameter, material designation, grade or coating of anchor bolt assembly.

3. High Strength Bolts: High strength bolts, including suitable nuts and hardened washers, shall conform to the following requirements:

- a) High strength bolts shall conform to ASTM A325 or ASTM A490 as shown on the plans. High-strength bolts used with coated steel shall be mechanically galvanized, unless otherwise specified. High-strength bolts used with uncoated weathering grades of steel shall be Type 3.

Nuts for ASTM A325 bolts shall conform to ASTM A563, grades DH, DH3, C, C3 and D. Where galvanized high-strength bolts are used, the nuts shall be galvanized, heat treated grade DH or DH3. Where Type 3 high-strength bolts are used, the nuts shall be grade C3 or DH3.

Nuts for ASTM A490 bolts shall conform to the requirements of ASTM A563, grades DH and DH3. Where Type 3 high-strength bolts are used, the nuts shall be grade DH3.

All galvanized nuts shall be lubricated with a lubricant containing a visible dye of any color that contrasts with the color of the galvanizing. Black bolts must be oily to the touch when delivered and installed.

Circular flat and square or rectangular beveled, hardened steel washers shall conform to ASTM F436. Unless otherwise specified, galvanized washers shall be furnished when galvanized high-strength bolts are specified, and washers with atmospheric corrosion resistance and weathering characteristics shall be furnished when Type 3 high-strength bolts are specified.

Compressible-washer-type direct tension indicator washers, used in conjunction with high strength bolts, shall conform to ASTM F959. Where galvanized high-strength bolts are used, the washers shall be galvanized in accordance with ASTM B695, Class 50. Where Type 3 high-strength bolts are used, the washers shall be galvanized in accordance with ASTM B695, Class 50 and coated with epoxy.

- b) Identifying Marks:** ASTM A325 for bolts and the specifications referenced therein for nuts require that bolts and nuts manufactured to the specification be identified by specific markings on the top of the bolt head and on one face of the nut. Head markings must identify the grade by the symbol "A325", the manufacturer and the type, if Type 2 or 3. Nut markings must identify the grade, the manufacturer and if Type 3, the type. Markings on direct tension indicators must identify the manufacturer and Type "325". Other washer markings must identify the manufacturer and if Type 3, the type.

ASTM A490 for bolts and the specifications reference therein for nuts require that bolts and nuts manufactured to the specifications be identified by specific markings on the top of the bolt head and on one face of the nut. Head markings must identify the grade by the symbol "A490", the manufacturer and the type, if Type 2 or 3. Nut markings must identify the grade, the manufacturer and if Type 3, the type. Markings on direct tension indicators must identify the manufacturer and Type "490". Other washer markings must identify the manufacturer and if Type 3, the type.

- c) Dimensions:** Bolt and nuts dimensions shall conform to the requirements for Heavy Hexagon Structural Bolts and for Heavy Semi-Finished Hexagon Nuts given in ANSI Standard B18.2.1 and B18.2.2, respectively.
- d) Galvanized Bolts:** Galvanized bolts shall conform to ASTM A325, Type 1. The bolts shall be hot-dip galvanized in accordance with ASTM A153, Class C or mechanically galvanized in accordance with ASTM B695, Class 50. Bolts, nuts, and washers of any assembly shall be galvanized by the same process. The nuts shall be overtapped to the minimum amount required for the fastener assembly, and shall be lubricated with a lubricant containing a visible dye so a visual check can be made for the lubricant at the time of field installation. Galvanized bolts shall be tension tested after galvanizing. ASTM A 490 bolts shall not be galvanized.
- e) Test Requirements:** The maximum hardness of A325 bolts 1" or less in diameter shall be 33 HRC.

Plain, ungalvanized nuts shall have a minimum hardness of 89 HRB.

Proof load tests, in accordance with the requirements of ASTM F606 Method 1, shall be required for the bolts. Wedge tests of full-size bolts are required in accordance with Section 8.3 of ASTM A325. Galvanized bolts shall be wedge tested after galvanizing. Proof load tests of ASTM A563 are required for nuts. Proof load tests for nuts used with galvanized bolts shall be performed after galvanizing, overtapping and lubricating.

Rotational-capacity tests are required and shall be performed on all plain or galvanized (after galvanizing) bolt, nut and washer assemblies by the manufacturer or distributor prior to shipping and by the Contractor at the job site.

The thickness of galvanizing on bolts, nuts and washers shall be measured. On bolts, it shall be measured on the wrench flats or on top of the bolt head, and on nuts it shall be measured on the wrench flats.

f) Certified Test Reports and Materials Certificates: The Contractor shall submit notarized copies of Certified Test Reports and Materials Certificates in conformance with Article 1.06.07 for fastener assemblies. In addition the Certified Test Reports and Materials Certificates shall include the following:

- a. Mill test reports shall indicate the place where the material was melted and manufactured.
- b. Test reports for proof load tests, wedge tests, and rotational-capacity tests shall indicate where the tests were performed, date of tests, location of where the components were manufactured and lot numbers.
- c. The test report for galvanized components shall indicate the thickness of the galvanizing.

g) Material Samples: Prior to incorporation into the work, the Contractor shall submit samples of the bolt assemblies to the Engineer for testing in accordance with the latest edition of the "Schedule of Minimum Requirements for Acceptance Testing". Samples shall be submitted for each diameter, length, material designation, grade, coating and manufacturer of bolt assembly.

4. Welded Stud Shear Connectors:

a) Materials: Stud shear connectors shall conform to the requirements of ASTM A 108, cold-drawn bar, Grades 1015, 1018 or 1020, either semi- or fully-killed. If flux-retaining caps are used, the steel for the caps shall be of a low carbon grade suitable for welding and shall comply with ASTM A 109.

Stud shear connectors shall be of a design suitable for electrically end-welding to steel with automatically timed stud welding equipment. The studs shall be of the sizes and dimensions noted on the plans. Flux for welding shall be furnished with each stud, either attached to the end of the stud or combined with the arc shield for automatic application in the welding operation. Each stud shall be furnished with a disposable ferrule of sufficient strength to remain intact during the welding operation and not crumble or break; it shall not be detrimental to the weld or create excessive slag.

Tensile properties, as determined by tests of bar stock after drawing or of finished studs, shall conform to the following requirements in which the yield strength is as determined by the 0.2% offset method:

Tensile strength (min.)	60,000 psi (415 megapascals)
Yield strength (min.)	50,000 psi (345 megapascals)
Elongation (min.)	20% in 2 inches (50 millimeters)
Reduction of area (min.)	50%

- b) **Test Methods:** Tensile properties shall be determined in accordance with the applicable sections of ASTM A 370. Tensile tests of finished studs shall be made on studs welded to test plates using a test fixture similar to that shown in Figure 7.2 of the current AASHTO/AWS D1.5 – Bridge Welding Code. If fracture occurs outside of the middle half of the gage length, the test shall be repeated.
- c) **Finish:** Finished studs shall be of uniform quality and condition, free from injurious laps, fins, seams, cracks, twists, bends or other injurious defects. Finish shall be as produced by cold-drawing, cold-rolling or machining.
- d) **Certified Test Reports and Materials Certificates:** The Contractor shall submit a certified copy of the in-plant quality control test report in conformance with Article 1.06.07. The Contractor shall submit a Materials Certificate in conformance with Article 1.06.07 for the welded studs.
- e) **Sample Materials for Testing:** Prior to incorporation into the work, the Contractor shall submit samples of the stud shear connectors to the Engineer for testing in accordance with the latest edition of the “Schedule of Minimum Requirements for Acceptance Testing”. One sample shall be submitted for each diameter and length of welded stud.

**CONNECTICUT
SUPPLEMENTAL SPECIFICATION
SECTION M.13
ROADSIDE DEVELOPMENT**

Delete article M.13.01 – Topsoil and replace it with the following:

“Article M.13.01 – Topsoil: The term topsoil used herein shall mean a soil meeting the soil textural classes established by the USDA Classification System based upon the proportion of sand, silt, and clay size particles after passing a No. 10 (2 millimeter) sieve and subjected to a particle size analysis. The topsoil shall contain 5% to 20% organic matter as determined by loss on ignition of oven-dried samples dried at 221° F (105° C). The pH range of the topsoil shall be 5.5 to 7.0.

The following textural classes shall be acceptable:

Loamy sand, including coarse, loamy fine, and loamy very fine sand, with not more than 80% sand

Sandy loam, including coarse, fine and very fine sandy loam

Loam

Clay loam, with not more than 30% clay

Silt loam, with not more than 60% silt

Sandy clay loam, with not more than 30% clay

All textural classes of topsoil with greater than 80% sand content will be rejected.

The topsoil furnished by the Contractor shall be a natural, workable soil that is screened and free of subsoil, refuse, stumps, roots, brush, weeds, rocks and stones over 1 1/4 inches (30 millimeters) in diameter, and any other foreign matter that would be detrimental to the proper development of plant growth.

The Contractor shall notify the Engineer of the location of the topsoil at least 15 calendar days prior to delivery. The topsoil and its source shall be inspected and approved by the Engineer before the material is delivered to the project. Any material delivered to the project, which does not meet specifications or which has become mixed with undue amounts of subsoil during any operation at the source or during placing and spreading, will be rejected and shall be replaced by the Contractor with acceptable material.

When topsoil is not furnished by the Contractor, it shall be material that is stripped in accordance with Section 2.02 or is furnished by the State, and will be tested as determined by the Engineer.

1. Planting Soil: Soil Material to be used for plant backfill shall be one of the following textural classes:

Loamy sand, with not more than 80% sand

Sandy loam

Loam

Clay loam, with not more than 30% clay

Silt loam, with not more than 60% silt

Sandy clay loam, with not more than 30% clay

Planting soil shall be premixed, consisting of approximately 50 % topsoil, 25 % compost or peat, and 25% native soil. Planting soil shall be loose, friable, and free from refuse, stumps, roots, brush, weeds, rocks and stones 2 inches (50 millimeters) in diameter. In addition, the material shall be free from any material that will prevent proper development and plant growth.

- (a) For ericaceous plants and broad-leaved evergreens requiring an acid soil, planting soil shall have a true pH of 4.5 to 5.5. If it has not, it shall be amended by the Contractor at his own expense to the proper pH range by mixing with sulphur.
- (b) Planting soil for general planting of nonacid-loving plants shall have a true pH value of 5.6 to 6.5. If it has not, it shall be amended by the Contractor at his own expense to the proper pH range by mixing with dolomitic limestone.

The amount of either sulphur or limestone required to adjust the planting soil to the proper pH range (above) shall be determined by the Engineer based on agronomic tests. The limestone shall conform to the requirements of Article M.13.02. The sulphur shall be commercial or flour sulphur, unadulterated, and shall be delivered in containers with the name of the manufacturer, material, analysis, and net weight (mass) appearing on each container.

The Engineer reserves the right to draw such samples and to perform such tests as he deems necessary to ensure that these specifications are met.”

**CONNECTICUT
SUPPLEMENTAL SPECIFICATION
SECTION M.16
TRAFFIC CONTROL SIGNALS**

Article M.16.04 – Poles:

Subarticle 1. Steel Poles:

(i) Wire Entrance Fitting:

In the second sentence, delete “required to accept the cables”.

Article M.16.06 – Traffic Signals:

In the 1st paragraph of subsection 9 replace “MIL” with “MILSPEC”.

Under the paragraph entitled Third Coat, replace the first two sentence with the following:

“Dark Green Enamel: Shall be Dark Green exterior baked enamel and shall comply with FS A-A 2962. The color shall be No. 14056, FS No. 595.”

and in the third sentence replace “MIL” with “MILSPEC.”

Article M.16.08 – Pedestrian Push Button

Subarticle – Painting

Delete the entire “Third Coat” paragraph and replace with the following:

Third Coat: Dark Green Enamel, shall be DARK GREEN exterior-baking enamel and shall comply with Federal Specifications A-A 2962. The color shall be No. 14056, Federal Standard No. 595.

**CONNECTICUT
SUPPLEMENTAL SPECIFICATION
SECTION M.17
ELASTOMERIC MATERIALS**

M.17.01 – Elastomeric Bearing Pads:

In the 2nd paragraph of subsection 4(b), replace “MS MIL” with “MILSPEC.”

**CONNECTICUT
SUPPLEMENTAL SPECIFICATION
SECTION M.18
SIGNING**

M.18.10 – Demountable Copy:

In the chart under subsection 3H, replace “MS MIL” with “MILSPEC.”

FHWA - Form 1273

REQUIRED CONTRACT PROVISIONS FEDERAL-AID CONSTRUCTION CONTRACTS

	Page
I. General	1
II. Nondiscrimination	1
III. Nonsegregated Facilities	3
IV. Payment of Predetermined Minimum Wage	3
V. Statements and Payrolls	5
VI. Record of Materials, Supplies, and Labor	5
VII. Subletting or Assigning the Contract	5
VIII. Safety: Accident Prevention	6
IX. False Statements Concerning Highway Projects	6
X. Implementation of Clean Air Act and Federal Water Pollution Control Act	6
XI. Certification Regarding Debarment, Suspension, Ineligibility, and Voluntary Exclusion	6
XII. Certification Regarding Use of Contract Funds for Lobbying	8

ATTACHMENTS

- A. Employment Preference for Appalachian Contracts
(included in Appalachian contracts only)

I. GENERAL

1. These contract provisions shall apply to all work performed on the contract by the contractor's own organization and with the assistance of workers under the contractor's immediate superintendence and to all work performed on the contract by piecework, station work, or by subcontract.

2. Except as otherwise provided for in each section, the contractor shall insert in each subcontract all of the stipulations contained in these Required Contract Provisions, and further require their inclusion in any lower tier subcontract or purchase order that may in turn be made. The Required Contract Provisions shall not be incorporated by reference in any case. The prime contractor shall be responsible for compliance by any subcontractor or lower tier subcontractor with these Required Contract Provisions.

3. A breach of any of the stipulations contained in these Required Contract Provisions shall be sufficient grounds for termination of the contract.

4. A breach of the following clauses of the Required Contract Provisions may also be grounds for debarment as provided in 29 CFR 5.12:

Section I, paragraph 2;
Section IV, paragraphs 1, 2, 3, 4, and 7;
Section V, paragraphs 1 and 2a through 2g.

5. Disputes arising out of the labor standards provisions of Section IV (except paragraph 5) and Section V of these Required Contract Provisions shall not be subject to the general disputes clause of this contract. Such disputes shall be resolved in accordance with the procedures of the U.S. Department of Labor (DOL) as set forth in 29 CFR 5, 6, and 7. Disputes within the meaning of this clause include disputes between the contractor (or any of its subcontractors) and the contracting agency, the DOL, or the contractor's employees or their representatives.

6. **Selection of Labor:** During the performance of this contract, the contractor shall not:

a. discriminate against labor from any other State, possession, or territory of the United States (except for employment preference for Appalachian contracts, when applicable, as specified in Attachment A), or

b. employ convict labor for any purpose within the limits of the project unless it is labor performed by convicts who are on parole, supervised release, or probation.

II. NONDISCRIMINATION

(Applicable to all Federal-aid construction contracts and to all

related subcontracts of \$10,000 or more.)

1. **Equal Employment Opportunity:** Equal employment opportunity (EEO) requirements not to discriminate and to take affirmative action to assure equal opportunity as set forth under laws, executive orders, rules, regulations (28 CFR 35, 29 CFR 1630 and 41 CFR 60) and orders of the Secretary of Labor as modified by the provisions prescribed herein, and imposed pursuant to 23 U.S.C. 140 shall constitute the EEO and specific affirmative action standards for the contractor's project activities under this contract. The Equal Opportunity Construction Contract Specifications set forth under 41 CFR 60-4.3 and the provisions of the American Disabilities Act of 1990 (42 U.S.C. 12101 *et seq.*) set forth under 28 CFR 35 and 29 CFR 1630 are incorporated by reference in this contract. In the execution of this contract, the contractor agrees to comply with the following minimum specific requirement activities of EEO:

a. The contractor will work with the State highway agency (SHA) and the Federal Government in carrying out EEO obligations and in their review of his/her activities under the contract.

b. The contractor will accept as his operating policy the following statement:

"It is the policy of this Company to assure that applicants are employed, and that employees are treated during employment, without regard to their race, religion, sex, color, national origin, age or disability. Such action shall include: employment, upgrading, demotion, or transfer; recruitment or recruitment advertising; layoff or termination; rates of pay or other forms of compensation; and selection for training, including apprenticeship, preapprenticeship, and/or on-the-job training."

2. **EEO Officer:** The contractor will designate and make known to the SHA contracting officers an EEO Officer who will have the responsibility for and must be capable of effectively administering and promoting an active contractor program of EEO and who must be assigned adequate authority and responsibility to do so.

3. **Dissemination of Policy:** All members of the contractor's staff who are authorized to hire, supervise, promote, and discharge employees, or who recommend such action, or who are substantially involved in such action, will be made fully cognizant of, and will implement, the contractor's EEO policy and contractual responsibilities to provide EEO in each grade and classification of employment. To ensure that the above agreement will be met, the following actions will be taken as a minimum:

a. Periodic meetings of supervisory and personnel office employees will be conducted before the start of work and then not less often than once every six months, at which time the contractor's EEO policy and its implementation will be reviewed and explained. The meetings will be conducted by the EEO Officer.

b. All new supervisory or personnel office employees will be given a thorough indoctrination by the EEO Officer, covering all major aspects of the contractor's EEO obligations within thirty days following their reporting for duty with the contractor.

c. All personnel who are engaged in direct recruitment for the project will be instructed by the EEO Officer in the contractor's procedures for locating and hiring minority group employees.

d. Notices and posters setting forth the contractor's EEO policy will be placed in areas readily accessible to employees, applicants for employment and potential employees.

e. The contractor's EEO policy and the procedures to implement such policy will be brought to the attention of employees by means of meetings, employee handbooks, or other appropriate means.

4. **Recruitment:** When advertising for employees, the contractor will include in all advertisements for employees the notation: "An Equal Opportunity Employer." All such advertisements will be placed

in publications having a large circulation among minority groups in the area from which the project work force would normally be derived.

a. The contractor will, unless precluded by a valid bargaining agreement, conduct systematic and direct recruitment through public and private employee referral sources likely to yield qualified minority group applicants. To meet this requirement, the contractor will identify sources of potential minority group employees, and establish with such identified sources procedures whereby minority group applicants may be referred to the contractor for employment consideration.

b. In the event the contractor has a valid bargaining agreement providing for exclusive hiring hall referrals, he is expected to observe the provisions of that agreement to the extent that the system permits the contractor's compliance with EEO contract provisions. (The DOL has held that where implementation of such agreements have the effect of discriminating against minorities or women, or obligates the contractor to do the same, such implementation violates Executive Order 11246, as amended.)

c. The contractor will encourage his present employees to refer minority group applicants for employment. Information and procedures with regard to referring minority group applicants will be discussed with employees.

5. **Personnel Actions:** Wages, working conditions, and employee benefits shall be established and administered, and personnel actions of every type, including hiring, upgrading, promotion, transfer, demotion, layoff, and termination, shall be taken without regard to race, color, religion, sex, national origin, age or disability. The following procedures shall be followed:

a. The contractor will conduct periodic inspections of project sites to insure that working conditions and employee facilities do not indicate discriminatory treatment of project site personnel.

b. The contractor will periodically evaluate the spread of wages paid within each classification to determine any evidence of discriminatory wage practices.

c. The contractor will periodically review selected personnel actions in depth to determine whether there is evidence of discrimination. Where evidence is found, the contractor will promptly take corrective action. If the review indicates that the discrimination may extend beyond the actions reviewed, such corrective action shall include all affected persons.

d. The contractor will promptly investigate all complaints of alleged discrimination made to the contractor in connection with his obligations under this contract, will attempt to resolve such complaints, and will take appropriate corrective action within a reasonable time. If the investigation indicates that the discrimination may affect persons other than the complainant, such corrective action shall include such other persons. Upon completion of each investigation, the contractor will inform every complainant of all of his avenues of appeal.

6. Training and Promotion:

a. The contractor will assist in locating, qualifying, and increasing the skills of minority group and women employees, and applicants for employment.

b. Consistent with the contractor's work force requirements and as permissible under Federal and State regulations, the contractor shall make full use of training programs, i.e., apprenticeship, and on-the-job training programs for the geographical area of contract performance. Where feasible, 25 percent of apprentices or trainees in each occupation shall be in their first year of apprenticeship or training. In the event a special provision for training is provided under this contract, this subparagraph will be superseded as indicated in the special provision.

c. The contractor will advise employees and applicants for employment of available training programs and entrance requirements for each.

d. The contractor will periodically review the training and promotion potential of minority group and women employees and will encourage eligible employees to apply for such training and promotion.

7. **Unions:** If the contractor relies in whole or in part upon unions as a source of employees, the contractor will use his/her best efforts to obtain the cooperation of such unions to increase opportunities for

minority groups and women within the unions, and to effect referrals by such unions of minority and female employees. Actions by the contractor either directly or through a contractor's association acting as agent will include the procedures set forth below:

a. The contractor will use best efforts to develop, in cooperation with the unions, joint training programs aimed toward qualifying more minority group members and women for membership in the unions and increasing the skills of minority group employees and women so that they may qualify for higher paying employment.

b. The contractor will use best efforts to incorporate an EEO clause into each union agreement to the end that such union will be contractually bound to refer applicants without regard to their race, color, religion, sex, national origin, age or disability.

c. The contractor is to obtain information as to the referral practices and policies of the labor union except that to the extent such information is within the exclusive possession of the labor union and such labor union refuses to furnish such information to the contractor, the contractor shall so certify to the SHA and shall set forth what efforts have been made to obtain such information.

d. In the event the union is unable to provide the contractor with a reasonable flow of minority and women referrals within the time limit set forth in the collective bargaining agreement, the contractor will, through independent recruitment efforts, fill the employment vacancies without regard to race, color, religion, sex, national origin, age or disability; making full efforts to obtain qualified and/or qualified minority group persons and women. (The DOL has held that it shall be no excuse that the union with which the contractor has a collective bargaining agreement providing for exclusive referral failed to refer minority employees.) In the event the union referral practice prevents the contractor from meeting the obligations pursuant to Executive Order 11246, as amended, and these special provisions, such contractor shall immediately notify the SHA.

8. **Selection of Subcontractors, Procurement of Materials and Leasing of Equipment:** The contractor shall not discriminate on the grounds of race, color, religion, sex, national origin, age or disability in the selection and retention of subcontractors, including procurement of materials and leases of equipment.

a. The contractor shall notify all potential subcontractors and suppliers of his/her EEO obligations under this contract.

b. Disadvantaged business enterprises (DBE), as defined in 49 CFR 23, shall have equal opportunity to compete for and perform subcontracts which the contractor enters into pursuant to this contract. The contractor will use his best efforts to solicit bids from and to utilize DBE subcontractors or subcontractors with meaningful minority group and female representation among their employees. Contractors shall obtain lists of DBE construction firms from SHA personnel.

c. The contractor will use his best efforts to ensure subcontractor compliance with their EEO obligations.

9. **Records and Reports:** The contractor shall keep such records as necessary to document compliance with the EEO requirements. Such records shall be retained for a period of three years following completion of the contract work and shall be available at reasonable times and places for inspection by authorized representatives of the SHA and the FHWA.

a. The records kept by the contractor shall document the following:

(1) The number of minority and non-minority group members and women employed in each work classification on the project;

(2) The progress and efforts being made in cooperation with unions, when applicable, to increase employment opportunities for minorities and women;

(3) The progress and efforts being made in locating, hiring, training, qualifying, and upgrading minority and female employees; and

(4) The progress and efforts being made in securing the services of DBE subcontractors or subcontractors with meaningful minority and female representation among their employees.

b. The contractors will submit an annual report to the SHA

each July for the duration of the project, indicating the number of minority, women, and non-minority group employees currently engaged in each work classification required by the contract work. This information is to be reported on Form FHWA-1391. If on-the-job training is being required by special provision, the contractor will be required to collect and report training data.

III. NONSEGREGATED FACILITIES

(Applicable to all Federal-aid construction contracts and to all related subcontracts of \$10,000 or more.)

a. By submission of this bid, the execution of this contract or subcontract, or the consummation of this material supply agreement or purchase order, as appropriate, the bidder, Federal-aid construction contractor, subcontractor, material supplier, or vendor, as appropriate, certifies that the firm does not maintain or provide for its employees any segregated facilities at any of its establishments, and that the firm does not permit its employees to perform their services at any location, under its control, where segregated facilities are maintained. The firm agrees that a breach of this certification is a violation of the EEO provisions of this contract. The firm further certifies that no employee will be denied access to adequate facilities on the basis of sex or disability.

b. As used in this certification, the term "segregated facilities" means any waiting rooms, work areas, restrooms and washrooms, restaurants and other eating areas, timeclocks, locker rooms, and other storage or dressing areas, parking lots, drinking fountains, recreation or entertainment areas, transportation, and housing facilities provided for employees which are segregated by explicit directive, or are, in fact, segregated on the basis of race, color, religion, national origin, age or disability, because of habit, local custom, or otherwise. The only exception will be for the disabled when the demands for accessibility override (e.g. disabled parking).

c. The contractor agrees that it has obtained or will obtain identical certification from proposed subcontractors or material suppliers prior to award of subcontracts or consummation of material supply agreements of \$10,000 or more and that it will retain such certifications in its files.

IV. PAYMENT OF PREDETERMINED MINIMUM WAGE

(Applicable to all Federal-aid construction contracts exceeding \$2,000 and to all related subcontracts, except for projects located on roadways classified as local roads or rural minor collectors, which are exempt.)

1. General:

a. All mechanics and laborers employed or working upon the site of the work will be paid unconditionally and not less often than once a week and without subsequent deduction or rebate on any account [except such payroll deductions as are permitted by regulations (29 CFR 3) issued by the Secretary of Labor under the Copeland Act (40 U.S.C. 276c)] the full amounts of wages and bona fide fringe benefits (or cash equivalents thereof) due at time of payment. The payment shall be computed at wage rates not less than those contained in the wage determination of the Secretary of Labor (hereinafter "the wage determination") which is attached hereto and made a part hereof, regardless of any contractual relationship which may be alleged to exist between the contractor or its subcontractors and such laborers and mechanics. The wage determination (including any additional classifications and wage rates conformed under paragraph 2 of this Section IV and the DOL poster (WH-1321) or Form FHWA-1495) shall be posted at all times by the contractor and its subcontractors at the site of the work in a prominent and accessible place where it can be easily seen by the workers. For the purpose of this Section, contributions made or costs reasonably anticipated for bona fide fringe benefits under Section 1(b)(2) of the Davis-Bacon Act (40 U.S.C. 276a) on behalf of laborers or mechanics are considered wages paid to such laborers or mechanics, subject to the provisions of Section IV, paragraph 3b, hereof. Also, for the purpose of this Section, regular contributions made or costs incurred for more than a weekly period (but not less often than quarterly) under plans, funds, or programs, which cover the particular weekly period, are deemed to be constructively made or incurred during such weekly period. Such laborers and mechanics shall be paid the appropriate wage rate and fringe benefits on the wage determination for the classification of work actually performed, without regard to skill, except as provided in paragraphs 4 and 5 of this Section IV.

b. Laborers or mechanics performing work in more than one classification may be compensated at the rate specified for each classification for the time actually worked therein, provided, that the employer's payroll records accurately set forth the time spent in each classification in which work is performed.

c. All rulings and interpretations of the Davis-Bacon Act and related acts contained in 29 CFR 1, 3, and 5 are herein incorporated by reference in this contract.

2. Classification:

a. The SHA contracting officer shall require that any class of laborers or mechanics employed under the contract, which is not listed in the wage determination, shall be classified in conformance with the wage determination.

b. The contracting officer shall approve an additional classification, wage rate and fringe benefits only when the following criteria have been met:

(1) the work to be performed by the additional classification requested is not performed by a classification in the wage determination;

(2) the additional classification is utilized in the area by the construction industry;

(3) the proposed wage rate, including any bona fide fringe benefits, bears a reasonable relationship to the wage rates contained in the wage determination; and

(4) with respect to helpers, when such a classification prevails in the area in which the work is performed.

c. If the contractor or subcontractors, as appropriate, the laborers and mechanics (if known) to be employed in the additional classification or their representatives, and the contracting officer agree on the classification and wage rate (including the amount designated for fringe benefits where appropriate), a report of the action taken shall be sent by the contracting officer to the DOL, Administrator of the Wage and Hour Division, Employment Standards Administration, Washington, D.C. 20210. The Wage and Hour Administrator, or an authorized representative, will approve, modify, or disapprove every additional classification action within 30 days of receipt and so advise the contracting officer or will notify the contracting officer within the 30-day period that additional time is necessary.

d. In the event the contractor or subcontractors, as appropriate, the laborers or mechanics to be employed in the additional classification or their representatives, and the contracting officer do not agree on the proposed classification and wage rate (including the amount designated for fringe benefits, where appropriate), the contracting officer shall refer the questions, including the views of all interested parties and the recommendation of the contracting officer, to the Wage and Hour Administrator for determination. Said Administrator, or an authorized representative, will issue a determination within 30 days of receipt and so advise the contracting officer or will notify the contracting officer within the 30-day period that additional time is necessary.

e. The wage rate (including fringe benefits where appropriate) determined pursuant to paragraph 2c or 2d of this Section IV shall be paid to all workers performing work in the additional classification from the first day on which work is performed in the classification.

3. Payment of Fringe Benefits:

a. Whenever the minimum wage rate prescribed in the contract for a class of laborers or mechanics includes a fringe benefit which is not expressed as an hourly rate, the contractor or subcontractors, as appropriate, shall either pay the benefit as stated in the wage determination or shall pay another bona fide fringe benefit or an hourly case equivalent thereof.

b. If the contractor or subcontractor, as appropriate, does not make payments to a trustee or other third person, he/she may consider as a part of the wages of any laborer or mechanic the amount of any costs reasonably anticipated in providing bona fide fringe benefits under a plan or program, provided, that the Secretary of Labor has found, upon the written request of the contractor, that the applicable standards of the Davis-Bacon Act have been met. The Secretary of Labor may require the contractor to set aside in a separate account assets for the meeting of obligations under the plan or program.

4. Apprentices and Trainees (Programs of the U.S. DOL) and Helpers:

a. Apprentices:

(1) Apprentices will be permitted to work at less than the predetermined rate for the work they performed when they are employed pursuant to and individually registered in a bona fide apprenticeship program registered with the DOL, Employment and Training Administration, Bureau of Apprenticeship and Training, or with a State apprenticeship agency recognized by the Bureau, or if a person is employed in his/her first 90 days of probationary employment as an apprentice in such an apprenticeship program, who is not individually registered in the program, but who has been certified by the Bureau of Apprenticeship and Training or a State apprenticeship agency (where appropriate) to be eligible for probationary employment as an apprentice.

(2) The allowable ratio of apprentices to journeyman-level employees on the job site in any craft classification shall not be greater than the ratio permitted to the contractor as to the entire work force under the registered program. Any employee listed on a payroll at an apprentice wage rate, who is not registered or otherwise employed as stated above, shall be paid not less than the applicable wage rate listed in the wage determination for the classification of work actually performed. In addition, any apprentice performing work on the job site in excess of the ratio permitted under the registered program shall be paid not less than the applicable wage rate on the wage determination for the work actually performed. Where a contractor or subcontractor is performing construction on a project in a locality other than that in which its program is registered, the ratios and wage rates (expressed in percentages of the journeyman-level hourly rate) specified in the contractor's or subcontractor's registered program shall be observed.

(3) Every apprentice must be paid at not less than the rate specified in the registered program for the apprentice's level of progress, expressed as a percentage of the journeyman-level hourly rate specified in the applicable wage determination. Apprentices shall be paid fringe benefits in accordance with the provisions of the apprenticeship program. If the apprenticeship program does not specify fringe benefits, apprentices must be paid the full amount of fringe benefits listed on the wage determination for the applicable classification. If the Administrator for the Wage and Hour Division determines that a different practice prevails for the applicable apprentice classification, fringes shall be paid in accordance with that determination.

(4) In the event the Bureau of Apprenticeship and Training, or a State apprenticeship agency recognized by the Bureau, withdraws approval of an apprenticeship program, the contractor or subcontractor will no longer be permitted to utilize apprentices at less than the applicable predetermined rate for the comparable work performed by regular employees until an acceptable program is approved.

b. Trainees:

(1) Except as provided in 29 CFR 5.16, trainees will not be permitted to work at less than the predetermined rate for the work performed unless they are employed pursuant to and individually registered in a program which has received prior approval, evidenced by formal certification by the DOL, Employment and Training Administration.

(2) The ratio of trainees to journeyman-level employees on the job site shall not be greater than permitted under the plan approved by the Employment and Training Administration. Any employee listed on the payroll at a trainee rate who is not registered and participating in a training plan approved by the Employment and Training Administration shall be paid not less than the applicable wage rate on the wage determination for the classification of work actually performed. In addition, any trainee performing work on the job site in excess of the ratio permitted under the registered program shall be paid not less than the applicable wage rate on the wage determination for the work actually performed.

(3) Every trainee must be paid at not less than the rate specified in the approved program for his/her level of progress, expressed as a percentage of the journeyman-level hourly rate specified in the applicable wage determination. Trainees shall be paid fringe benefits in accordance with the provisions of the trainee program. If the trainee program does not mention fringe benefits, trainees shall be paid the full amount of fringe benefits listed on the wage determination unless the Administrator of the Wage and Hour

Division determines that there is an apprenticeship program associated with the corresponding journeyman-level wage rate on the wage determination which provides for less than full fringe benefits for apprentices, in which case such trainees shall receive the same fringe benefits as apprentices.

(4) In the event the Employment and Training Administration withdraws approval of a training program, the contractor or subcontractor will no longer be permitted to utilize trainees at less than the applicable predetermined rate for the work performed until an acceptable program is approved.

c. Helpers:

Helpers will be permitted to work on a project if the helper classification is specified and defined on the applicable wage determination or is approved pursuant to the conformance procedure set forth in Section IV.2. Any worker listed on a payroll at a helper wage rate, who is not a helper under an approved definition, shall be paid not less than the applicable wage rate on the wage determination for the classification of work actually performed.

5. Apprentices and Trainees (Programs of the U.S. DOT):

Apprentices and trainees working under apprenticeship and skill training programs which have been certified by the Secretary of Transportation as promoting EEO in connection with Federal-aid highway construction programs are not subject to the requirements of paragraph 4 of this Section IV. The straight time hourly wage rates for apprentices and trainees under such programs will be established by the particular programs. The ratio of apprentices and trainees to journeymen shall not be greater than permitted by the terms of the particular program.

6. Withholding:

The SHA shall upon its own action or upon written request of an authorized representative of the DOL withhold, or cause to be withheld, from the contractor or subcontractor under this contract or any other Federal contract with the same prime contractor, or any other Federally-assisted contract subject to Davis-Bacon prevailing wage requirements which is held by the same prime contractor, as much of the accrued payments or advances as may be considered necessary to pay laborers and mechanics, including apprentices, trainees, and helpers, employed by the contractor or any subcontractor the full amount of wages required by the contract. In the event of failure to pay any laborer or mechanic, including any apprentice, trainee, or helper, employed or working on the site of the work, all or part of the wages required by the contract, the SHA contracting officer may, after written notice to the contractor, take such action as may be necessary to cause the suspension of any further payment, advance, or guarantee of funds until such violations have ceased.

7. Overtime Requirements:

No contractor or subcontractor contracting for any part of the contract work which may require or involve the employment of laborers, mechanics, watchmen, or guards (including apprentices, trainees, and helpers described in paragraphs 4 and 5 above) shall require or permit any laborer, mechanic, watchman, or guard in any workweek in which he/she is employed on such work, to work in excess of 40 hours in such workweek unless such laborer, mechanic, watchman, or guard receives compensation at a rate not less than one-and-one-half times his/her basic rate of pay for all hours worked in excess of 40 hours in such workweek.

8. Violation:

Liability for Unpaid Wages; Liquidated Damages: In the event of any violation of the clause set forth in paragraph 7 above, the contractor and any subcontractor responsible thereof shall be liable to the affected employee for his/her unpaid wages. In addition, such contractor and subcontractor shall be liable to the United States (in the case of work done under contract for the District of Columbia or a territory, to such District or to such territory) for liquidated damages. Such liquidated damages shall be computed with respect to each individual laborer, mechanic, watchman, or guard employed in violation of the clause set forth in paragraph 7, in the sum of \$10 for each calendar day on which such employee was required or permitted to work in excess of the standard work week of 40 hours without payment of the overtime wages required by the clause set forth in paragraph 7.

9. Withholding for Unpaid Wages and Liquidated Damages:

The SHA shall upon its own action or upon written request of any authorized representative of the DOL withhold, or cause to be withheld, from any monies payable on account of work performed by the contractor or subcontractor under any such contract or any other Federal contract with the same prime contractor, or any other Federally-assisted contract subject to the Contract Work Hours and Safety Standards Act, which is held by the same prime contractor, such sums as may be determined to be necessary to satisfy any liabilities of such contractor or subcontractor for unpaid wages and liquidated damages as provided in the clause set forth in paragraph 8 above.

V. STATEMENTS AND PAYROLLS

(Applicable to all Federal-aid construction contracts exceeding \$2,000 and to all related subcontracts, except for projects located on roadways classified as local roads or rural collectors, which are exempt.)

1. Compliance with Copeland Regulations (29 CFR 3):

The contractor shall comply with the Copeland Regulations of the Secretary of Labor which are herein incorporated by reference.

2. Payrolls and Payroll Records:

a. Payrolls and basic records relating thereto shall be maintained by the contractor and each subcontractor during the course of the work and preserved for a period of 3 years from the date of completion of the contract for all laborers, mechanics, apprentices, trainees, watchmen, helpers, and guards working at the site of the work.

b. The payroll records shall contain the name, social security number, and address of each such employee; his or her correct classification; hourly rates of wages paid (including rates of contributions or costs anticipated for bona fide fringe benefits or cash equivalent thereof of the types described in Section 1(b)(2)(B) of the Davis Bacon Act); daily and weekly number of hours worked; deductions made; and actual wages paid. In addition, for Appalachian contracts, the payroll records shall contain a notation indicating whether the employee does, or does not, normally reside in the labor area as defined in Attachment A, paragraph 1. Whenever the Secretary of Labor, pursuant to Section IV, paragraph 3b, has found that the wages of any laborer or mechanic include the amount of any costs reasonably anticipated in providing benefits under a plan or program described in Section 1(b)(2)(B) of the Davis Bacon Act, the contractor and each subcontractor shall maintain records which show that the commitment to provide such benefits is enforceable, that the plan or program is financially responsible, that the plan or program has been communicated in writing to the laborers or mechanics affected, and show the cost anticipated or the actual cost incurred in providing benefits. Contractors or subcontractors employing apprentices or trainees under approved programs shall maintain written evidence of the registration of apprentices and trainees, and ratios and wage rates prescribed in the applicable programs.

c. Each contractor and subcontractor shall furnish, each week in which any contract work is performed, to the SHA resident engineer a payroll of wages paid each of its employees (including apprentices, trainees, and helpers, described in Section IV, paragraphs 4 and 5, and watchmen and guards engaged on work during the preceding weekly payroll period). The payroll submitted shall set out accurately and completely all of the information required to be maintained under paragraph 2b of this Section V. This information may be submitted in any form desired. Optional Form WH-347 is available for this purpose and may be purchased from the Superintendent of Documents (Federal stock number 029-005-0014-1), U.S. Government Printing Office, Washington, D.C. 20402. The prime contractor is responsible for the submission of copies of payrolls by all subcontractors.

d. Each payroll submitted shall be accompanied by a "Statement of Compliance," signed by the contractor or subcontractor or his/her agent who pays or supervises the payment of the persons employed under the contract and shall certify the following:

(1) that the payroll for the payroll period contains the information required to be maintained under paragraph 2b of this Section V and that such information is correct and complete;

(2) that such laborer or mechanic (including each helper, apprentice, and trainee) employed on the contract during the payroll period has been paid the full weekly wages earned, without rebate, either directly or indirectly, and that no deductions have been made

either directly or indirectly from the full wages earned, other than permissible deductions as set forth in the Regulations, 29 CFR 3;

(3) that each laborer or mechanic has been paid not less than the applicable wage rate and fringe benefits or cash equivalent for the classification of work performed, as specified in the applicable wage determination incorporated into the contract.

e. The weekly submission of a properly executed certification set forth on the reverse side of Optional Form WH-347 shall satisfy the requirement for submission of the "Statement of Compliance" required by paragraph 2d of this Section V.

f. The falsification of any of the above certifications may subject the contractor to civil or criminal prosecution under 18 U.S.C. 1001 and 31 U.S.C. 231.

g. The contractor or subcontractor shall make the records required under paragraph 2b of this Section V available for inspection, copying, or transcription by authorized representatives of the SHA, the FHWA, or the DOL, and shall permit such representatives to interview employees during working hours on the job. If the contractor or subcontractor fails to submit the required records or to make them available, the SHA, the FHWA, the DOL, or all may, after written notice to the contractor, sponsor, applicant, or owner, take such actions as may be necessary to cause the suspension of any further payment, advance, or guarantee of funds. Furthermore, failure to submit the required records upon request or to make such records available may be grounds for debarment action pursuant to 29 CFR 5.12.

VI. RECORD OF MATERIALS, SUPPLIES, AND LABOR

1. On all Federal-aid contracts on the National Highway System, except those which provide solely for the installation of protective devices at railroad grade crossings, those which are constructed on a force account or direct labor basis, highway beautification contracts, and contracts for which the total final construction cost for roadway and bridge is less than \$1,000,000 (23 CFR 635) the contractor shall:

a. Become familiar with the list of specific materials and supplies contained in Form FHWA-47, "Statement of Materials and Labor Used by Contractor of Highway Construction Involving Federal Funds," prior to the commencement of work under this contract.

b. Maintain a record of the total cost of all materials and supplies purchased for and incorporated in the work, and also of the quantities of those specific materials and supplies listed on Form FHWA-47, and in the units shown on Form FHWA-47.

c. Furnish, upon the completion of the contract, to the SHA resident engineer on Form FHWA-47 together with the data required in paragraph 1b relative to materials and supplies, a final labor summary of all contract work indicating the total hours worked and the total amount earned.

2. At the prime contractor's option, either a single report covering all contract work or separate reports for the contractor and for each subcontract shall be submitted.

VII. SUBLETTING OR ASSIGNING THE CONTRACT

1. The contractor shall perform with its own organization contract work amounting to not less than 30 percent (or a greater percentage if specified elsewhere in the contract) of the total original contract price, excluding any specialty items designated by the State. Specialty items may be performed by subcontract and the amount of any such specialty items performed may be deducted from the total original contract price before computing the amount of work required to be performed by the contractor's own organization (23 CFR 635).

a. "Its own organization" shall be construed to include only workers employed and paid directly by the prime contractor and equipment owned or rented by the prime contractor, with or without operators. Such term does not include employees or equipment of

a subcontractor, assignee, or agent of the prime contractor.

b. "Specialty Items" shall be construed to be limited to work that requires highly specialized knowledge, abilities, or equipment not ordinarily available in the type of contracting organizations qualified and expected to bid on the contract as a whole and in general are to be limited to minor components of the overall contract.

2. The contract amount upon which the requirements set forth in paragraph 1 of Section VII is computed includes the cost of material and manufactured products which are to be purchased or produced by the contractor under the contract provisions.

3. The contractor shall furnish (a) a competent superintendent or supervisor who is employed by the firm, has full authority to direct performance of the work in accordance with the contract requirements, and is in charge of all construction operations (regardless of who performs the work) and (b) such other of its own organizational resources (supervision, management, and engineering services) as the SHA contracting officer determines is necessary to assure the performance of the contract.

4. No portion of the contract shall be sublet, assigned or otherwise disposed of except with the written consent of the SHA contracting officer, or authorized representative, and such consent when given shall not be construed to relieve the contractor of any responsibility for the fulfillment of the contract. Written consent will be given only after the SHA has assured that each subcontract is evidenced in writing and that it contains all pertinent provisions and requirements of the prime contract.

VIII. SAFETY: ACCIDENT PREVENTION

1. In the performance of this contract the contractor shall comply with all applicable Federal, State, and local laws governing safety, health, and sanitation (23 CFR 635). The contractor shall provide all safeguards, safety devices and protective equipment and take any other needed actions as it determines, or as the SHA contracting officer may determine, to be reasonably necessary to protect the life and health of employees on the job and the safety of the public and to protect property in connection with the performance of the work covered by the contract.

2. It is a condition of this contract, and shall be made a condition of each subcontract, which the contractor enters into pursuant to this contract, that the contractor and any subcontractor shall not permit any employee, in performance of the contract, to work in surroundings or under conditions which are unsanitary, hazardous or dangerous to his/her health or safety, as determined under construction safety and health standards (29 CFR 1926) promulgated by the Secretary of Labor, in accordance with Section 107 of the Contract Work Hours and Safety Standards Act (40 U.S.C. 333).

3. Pursuant to 29 CFR 1926.3, it is a condition of this contract that the Secretary of Labor or authorized representative thereof, shall have right of entry to any site of contract performance to inspect or investigate the matter of compliance with the construction safety and health standards and to carry out the duties of the Secretary under Section 107 of the Contract Work Hours and Safety Standards Act (40 U.S.C. 333).

IX. FALSE STATEMENTS CONCERNING HIGHWAY PROJECTS

In order to assure high quality and durable construction in conformity with approved plans and specifications and a high degree of reliability on statements and representations made by engineers, contractors, suppliers, and workers on Federal-aid highway projects, it is essential that all persons concerned with the project perform their functions as carefully, thoroughly, and honestly as possible. Willful falsification, distortion, or misrepresentation with respect to any facts related to the project is a violation of Federal law. To prevent any misunderstanding regarding the seriousness of these and similar acts, the following notice shall be posted on each Federal-aid highway project (23 CFR 635) in one or more places where it is readily available to all persons concerned with the project:

NOTICE TO ALL PERSONNEL ENGAGED ON FEDERAL-AID HIGHWAY PROJECTS

18 U.S.C. 1020 reads as follows:

"Whoever, being an officer, agent, or employee of the United States, or of any State or Territory, or whoever, whether a person, association, firm, or corporation, knowingly makes any false statement, false representation, or false report as to the character, quality,

quantity, or cost of the material used or to be used, or the quantity or quality of the work performed or to be performed, or the cost thereof in connection with the submission of plans, maps, specifications, contracts, or costs of construction on any highway or related project submitted for approval to the Secretary of Transportation; or

Whoever knowingly makes any false statement, false representation, false report or false claim with respect to the character, quality, quantity, or cost of any work performed or to be performed, or materials furnished or to be furnished, in connection with the construction of any highway or related project approved by the Secretary of Transportation; or

Whoever knowingly makes any false statement or false representation as to material fact in any statement, certificate, or report submitted pursuant to provisions of the Federal-aid Roads Act approved July 1, 1916, (39 Stat. 355), as amended and supplemented;

Shall be fined not more than \$10,000 or imprisoned not more than 5 years or both."

X. IMPLEMENTATION OF CLEAN AIR ACT AND FEDERAL WATER POLLUTION CONTROL ACT

(Applicable to all Federal-aid construction contracts and to all related subcontracts of \$100,000 or more.)

By submission of this bid or the execution of this contract, or subcontract, as appropriate, the bidder, Federal-aid construction contractor, or subcontractor, as appropriate, will be deemed to have stipulated as follows:

1. That any facility that is or will be utilized in the performance of this contract, unless such contract is exempt under the Clean Air Act, as amended (42 U.S.C. 1857 *et seq.*, as amended by Pub.L. 91-604), and under the Federal Water Pollution Control Act, as amended (33 U.S.C. 1251 *et seq.*, as amended by Pub.L. 92-500), Executive Order 11738, and regulations in implementation thereof (40 CFR 15) is not listed, on the date of contract award, on the U.S. Environmental Protection Agency (EPA) List of Violating Facilities pursuant to 40 CFR 15.20.

2. That the firm agrees to comply and remain in compliance with all the requirements of Section 114 of the Clean Air Act and Section 308 of the Federal Water Pollution Control Act and all regulations and guidelines listed thereunder.

3. That the firm shall promptly notify the SHA of the receipt of any communication from the Director, Office of Federal Activities, EPA, indicating that a facility that is or will be utilized for the contract is under consideration to be listed on the EPA List of Violating Facilities.

4. That the firm agrees to include or cause to be included the requirements of paragraph 1 through 4 of this Section X in every nonexempt subcontract, and further agrees to take such action as the government may direct as a means of enforcing such requirements.

XI. CERTIFICATION REGARDING DEBARMENT, SUSPENSION, INELIGIBILITY AND VOLUNTARY EXCLUSION

1. Instructions for Certification - Primary Covered Transactions:

(Applicable to all Federal-aid contracts - 49 CFR 29)

a. By signing and submitting this proposal, the prospective primary participant is providing the certification set out below.

b. The inability of a person to provide the certification set out below will not necessarily result in denial of participation in this covered transaction. The prospective participant shall submit an explanation of why it cannot provide the certification set out below. The certification or explanation will be considered in connection with the department or agency's determination whether to enter into this transaction. However, failure of the prospective primary participant to furnish a certification or an explanation shall disqualify such a person from participation in this transaction.

c. The certification in this clause is a material representation of fact upon which reliance was placed when the department or agency determined to enter into this transaction. If it is later determined that the prospective primary participant knowingly rendered an erroneous certification, in addition to other remedies available to the Federal Government, the department or agency may terminate this

transaction for cause of default.

d. The prospective primary participant shall provide immediate written notice to the department or agency to whom this proposal is submitted if any time the prospective primary participant learns that its certification was erroneous when submitted or has become erroneous by reason of changed circumstances.

e. The terms "covered transaction," "debarred," "suspended," "ineligible," "lower tier covered transaction," "participant," "person," "primary covered transaction," "principal," "proposal," and "voluntarily excluded," as used in this clause, have the meanings set out in the Definitions and Coverage sections of rules implementing Executive Order 12549. You may contact the department or agency to which this proposal is submitted for assistance in obtaining a copy of those regulations.

f. The prospective primary participant agrees by submitting this proposal that, should the proposed covered transaction be entered into, it shall not knowingly enter into any lower tier covered transaction with a person who is debarred, suspended, declared ineligible, or voluntarily excluded from participation in this covered transaction, unless authorized by the department or agency entering into this transaction.

g. The prospective primary participant further agrees by submitting this proposal that it will include the clause titled "Certification Regarding Debarment, Suspension, Ineligibility and Voluntary Exclusion-Lower Tier Covered Transaction," provided by the department or agency entering into this covered transaction, without modification, in all lower tier covered transactions and in all solicitations for lower tier covered transactions.

h. A participant in a covered transaction may rely upon a certification of a prospective participant in a lower tier covered transaction that is not debarred, suspended, ineligible, or voluntarily excluded from the covered transaction, unless it knows that the certification is erroneous. A participant may decide the method and frequency by which it determines the eligibility of its principals. Each participant may, but is not required to, check the nonprocurement portion of the "Lists of Parties Excluded From Federal Procurement or Nonprocurement Programs" (Nonprocurement List) which is compiled by the General Services Administration.

i. Nothing contained in the foregoing shall be construed to require establishment of a system of records in order to render in good faith the certification required by this clause. The knowledge and information of participant is not required to exceed that which is normally possessed by a prudent person in the ordinary course of business dealings.

j. Except for transactions authorized under paragraph f of these instructions, if a participant in a covered transaction knowingly enters into a lower tier covered transaction with a person who is suspended, debarred, ineligible, or voluntarily excluded from participation in this transaction, in addition to other remedies available to the Federal Government, the department or agency may terminate this transaction for cause or default.

Certification Regarding Debarment, Suspension, Ineligibility and Voluntary Exclusion--Primary Covered Transactions

1. The prospective primary participant certifies to the best of its knowledge and belief, that it and its principals:

a. Are not presently debarred, suspended, proposed for debarment, declared ineligible, or voluntarily excluded from covered transactions by any Federal department or agency;

b. Have not within a 3-year period preceding this proposal been convicted of or had a civil judgement rendered against them for commission of fraud or a criminal offense in connection with obtaining, attempting to obtain, or performing a public (Federal, State or local) transaction or contract under a public transaction; violation of Federal or State antitrust statutes or commission of embezzlement, theft, forgery, bribery, falsification or destruction of records, making false statements, or receiving stolen property;

c. Are not presently indicted for or otherwise criminally or civilly charged by a governmental entity (Federal, State or local) with commission of any of the offenses enumerated in paragraph 1b of this certification; and

d. Have not within a 3-year period preceding this application/proposal had one or more public transactions (Federal, State or local) terminated for cause or default.

2. Where the prospective primary participant is unable to certify to any of the statements in this certification, such prospective participant shall attach an explanation to this proposal.

2. Instructions for Certification - Lower Tier Covered Transactions:

(Applicable to all subcontracts, purchase orders and other lower tier transactions of \$25,000 or more - 49 CFR 29)

a. By signing and submitting this proposal, the prospective lower tier is providing the certification set out below.

b. The certification in this clause is a material representation of fact upon which reliance was placed when this transaction was entered into. If it is later determined that the prospective lower tier participant knowingly rendered an erroneous certification, in addition to other remedies available to the Federal Government, the department, or agency with which this transaction originated may pursue available remedies, including suspension and/or debarment.

c. The prospective lower tier participant shall provide immediate written notice to the person to which this proposal is submitted if at any time the prospective lower tier participant learns that its certification was erroneous by reason of changed circumstances.

d. The terms "covered transaction," "debarred," "suspended," "ineligible," "primary covered transaction," "participant," "person," "principal," "proposal," and "voluntarily excluded," as used in this clause, have the meanings set out in the Definitions and Coverage sections of rules implementing Executive Order 12549. You may contact the person to which this proposal is submitted for assistance in obtaining a copy of those regulations.

e. The prospective lower tier participant agrees by submitting this proposal that, should the proposed covered transaction be entered into, it shall not knowingly enter into any lower tier covered transaction with a person who is debarred, suspended, declared ineligible, or voluntarily excluded from participation in this covered transaction, unless authorized by the department or agency with which this transaction originated.

f. The prospective lower tier participant further agrees by submitting this proposal that it will include this clause titled "Certification Regarding Debarment, Suspension, Ineligibility and Voluntary Exclusion-Lower Tier Covered Transaction," without modification, in all lower tier covered transactions and in all solicitations for lower tier covered transactions.

g. A participant in a covered transaction may rely upon a certification of a prospective participant in a lower tier covered transaction that is not debarred, suspended, ineligible, or voluntarily excluded from the covered transaction, unless it knows that the certification is erroneous. A participant may decide the method and

frequency by which it determines the eligibility of its principals. Each participant may, but is not required to, check the Nonprocurement List.

h. Nothing contained in the foregoing shall be construed to require establishment of a system of records in order to render in good faith the certification required by this clause. The knowledge and information of participant is not required to exceed that which is normally possessed by a prudent person in the ordinary course of business dealings.

i. Except for transactions authorized under paragraph e of these instructions, if a participant in a covered transaction knowingly enters into a lower tier covered transaction with a person who is suspended, debarred, ineligible, or voluntarily excluded from participation in this transaction, in addition to other remedies available to the Federal Government, the department or agency with which this transaction originated may pursue available remedies, including suspension and/or debarment.

Certification Regarding Debarment, Suspension, Ineligibility and Voluntary Exclusion--Lower Tier Covered Transactions:

1. The prospective lower tier participant certifies, by submission of this proposal, that neither it nor its principals is presently debarred, suspended, proposed for debarment, declared ineligible, or voluntarily excluded from participation in this transaction by any Federal department or agency.

2. Where the prospective lower tier participant is unable to certify to any of the statements in this certification, such prospective participant shall attach an explanation to this proposal.

XII. CERTIFICATION REGARDING USE OF CONTRACT FUNDS FOR LOBBYING

(Applicable to all Federal-aid construction contracts and to all related subcontracts which exceed \$100,000 - 49 CFR 20)

1. The prospective participant certifies, by signing and submitting this bid or proposal, to the best of his or her knowledge and belief, that:

a. No Federal appropriated funds have been paid or will be paid, by or on behalf of the undersigned, to any person for influencing or attempting to influence an officer or employee of any Federal agency, a Member of Congress, an officer or employee of Congress, or an employee of a Member of Congress in connection with the awarding of any Federal contract, the making of any Federal grant, the making of any Federal loan, the entering into of any cooperative agreement, and the extension, continuation, renewal, amendment, or modification of any Federal contract, grant, loan, or cooperative agreement.

b. If any funds other than Federal appropriated funds have been paid or will be paid to any person for influencing or attempting to influence an officer or employee of any Federal agency, a Member of Congress, an officer or employee of Congress, or an employee of a Member of Congress in connection with this Federal contract, grant, loan, or cooperative agreement, the undersigned shall complete and submit Standard Form-LLL, "Disclosure Form to Report Lobbying," in accordance with its instructions.

2. This certification is a material representation of fact upon which reliance was placed when this transaction was made or entered into. Submission of this certification is a prerequisite for making or entering into this transaction imposed by 31 U.S.C. 1352. Any person who fails to file the required certification shall be subject to a civil penalty of not less than \$10,000 and not more than \$100,000 for each such failure.

3. The prospective participant also agrees by submitting his or her bid or proposal that he or she shall require that the language of this certification be included in all lower tier subcontracts, which exceed \$100,000 and that all such recipients shall certify and disclose accordingly.

**ATTACHMENT A - EMPLOYMENT PREFERENCE FOR
APPALACHIAN CONTRACTS**
(Applicable to Appalachian contracts only.)

1. During the performance of this contract, the contractor undertaking to do work which is, or reasonably may be, done as on-site work, shall give preference to qualified persons who regularly reside in the labor area as designated by the DOL wherein the contract work is situated, or the subregion, or the Appalachian counties of the State wherein the contract work is situated, except:

a. To the extent that qualified persons regularly residing in the area are not available.

b. For the reasonable needs of the contractor to employ supervisory or specially experienced personnel necessary to assure an efficient execution of the contract work.

c. For the obligation of the contractor to offer employment to present or former employees as the result of a lawful collective bargaining contract, provided that the number of nonresident persons employed under this subparagraph 1c shall not exceed 20 percent of the total number of employees employed by the contractor on the contract work, except as provided in subparagraph 4 below.

2. The contractor shall place a job order with the State Employment Service indicating (a) the classifications of the laborers, mechanics and other employees required to perform the contract work, (b) the number of employees required in each classification,

(c) the date on which he estimates such employees will be required, and (d) any other pertinent information required by the State Employment Service to complete the job order form. The job order may be placed with the State Employment Service in writing or by telephone. If during the course of the contract work, the information submitted by the contractor in the original job order is substantially modified, he shall promptly notify the State Employment Service.

3. The contractor shall give full consideration to all qualified job applicants referred to him by the State Employment Service. The contractor is not required to grant employment to any job applicants who, in his opinion, are not qualified to perform the classification of work required.

4. If, within 1 week following the placing of a job order by the contractor with the State Employment Service, the State Employment Service is unable to refer any qualified job applicants to the contractor, or less than the number requested, the State Employment Service will forward a certificate to the contractor indicating the unavailability of applicants. Such certificate shall be made a part of the contractor's permanent project records. Upon receipt of this certificate, the contractor may employ persons who do not normally reside in the labor area to fill positions covered by the certificate, notwithstanding the provisions of subparagraph 1c above.

5. The contractor shall include the provisions of Sections 1 through 4 of this Attachment A in every subcontract for work which is, or reasonably may be, done as on-site work.

**Amendment to Required Contract Provisions (FHWA – Form 1273)
Federal-Aid Construction Contracts**

NOTICE TO CONTRACTORS:

This notice hereby amends the “Required Contract Provisions – Federal-Aid Construction Contracts” (FHWA Form 1273) language as stated below .

Delete Section VI, “Record of Materials, Supplies and Labor” in its entirety. Form FHWA-47, “Statement of Materials and Labor Used by Contractor of Highway Construction Involving Federal Funds” has been discontinued.

State of Connecticut Required Contract Provisions.

SUBSTITUTION OF SECURITIES FOR RETAINAGES ON STATE CONTRACTS AND SUBCONTRACTS

The contractor is advised of the provisions of Section 3-112a of the General Statutes of the State of Connecticut, as revised which is quoted as follows:

(a) Under any contract made or awarded by the state, or by any public department or official thereof, or under any subcontract made directly thereunder with the contractor, the contractor and any subcontractor may, from time to time, withdraw the whole or any portion of the amount retained for payments to the contractor or subcontractors, as the case may be, pursuant to the terms of the contract or subcontracts, upon depositing with the Comptroller (1) United States Treasury bonds, United States Treasury notes, United States Treasury certificates of indebtedness or United States Treasury bills, or (2) bonds or notes of the state of Connecticut or (3) bonds of any political subdivision in the state of Connecticut. No amount shall be withdrawn in excess of the market value of the securities at the time of deposit or of the par value of such securities, whichever is lower.

(b) The Comptroller shall, on a regular basis, collect all interest or income on the obligations so deposited and shall pay the same, when and as collected, to the contractor and the subcontractors who deposited the obligations. If the deposit is in the form of coupon bonds, the Comptroller shall deliver each coupon as it matures to the contractor and the subcontractors.

(c) Any amount deducted by the state, or by any public department or official thereof, pursuant to the terms of the contract, and subcontracts made directly thereunder with the contractor, from the retainages due the contractor and said subcontractors, shall be deducted, first from that portion of the retainages for which no security has been substituted, then from the proceeds of any deposited security. In the latter case, the contractor and the subcontractors shall be entitled to receive interest, coupons or income only from those securities which remain after such amount has been deducted.

1. Non-discrimination. References in this section to "contract" shall mean this Contract and references to "contractor" shall mean the Contractor.

(a) The following subsections are set forth here as required by section 4a-60 of the Connecticut General Statutes:

(1) The contractor agrees and warrants that in the performance of the contract such contractor will not discriminate or permit discrimination against any person or group of persons on the grounds of race, color, religious creed, age, marital status, national origin, ancestry, sex, mental retardation, mental disability or physical disability, including, but not limited to, blindness, unless it is shown by such contractor that such disability prevents performance of the work involved, in any manner prohibited by the laws of the United States or of the state of Connecticut. The contractor further agrees to take affirmative action to insure that applicants with job-related qualifications are employed and that employees are treated when employed without regard to their race, color, religious creed, age, marital status, national origin, ancestry, sex, mental retardation, mental disability or physical disability, including, but not limited to, blindness, unless it is shown by such contractor that such disability prevents performance of the work involved; (2) the contractor agrees, in all solicitations or advertisements for employees placed by or on behalf of the contractor, to state that it is an "affirmative action-equal opportunity employer" in accordance with regulations adopted by the commission; (3) the contractor agrees to provide each labor union or representative of workers with which such contractor has a collective bargaining agreement or other contract or understanding and each vendor with which such contractor has a contract or understanding, a notice to be provided by the commission advising the labor union or workers' representative of the contractor's commitments under this section, and to post copies of the notice in conspicuous places available to employees and applicants for employment; (4) the contractor agrees to comply with each provision of this section and sections 46a-68e and 46a-68f and with each regulation or relevant order issued by said commission pursuant to sections 46a-56, 46a-68e and 46a-68f; (5) the contractor agrees to provide the Commission on Human Rights and Opportunities with such information requested by the commission, and permit access to pertinent books, records and accounts, concerning the employment practices and procedures of the contractor as relate to the provisions of this section and section 46a-56.

(b) If the contract is a public works contract, the contractor agrees and warrants that he will make good faith efforts to employ minority business enterprises as subcontractors and suppliers of materials on such public works project.

(c) "Minority business enterprise" means any small contractor or supplier of materials fifty-one per cent or more of the capital stock, if any, or assets of which is owned by a person or persons: (1) Who are active in the daily affairs of the enterprise, (2) who have the power to direct the management and policies of the enterprise and (3) who are members of a minority, as such term is defined in subsection (a) of section 32-9n; and "good faith" means that degree of diligence which a reasonable person would exercise in the performance of legal duties and obligations. "Good faith efforts" shall include, but not be limited to, those reasonable initial efforts necessary to comply with statutory or regulatory requirements and additional or substituted efforts when it is determined that such initial efforts will not be sufficient to comply with such requirements.

(d) Determination of the contractor's good faith efforts shall include but shall not be limited to the following factors: The contractor's employment and subcontracting policies, patterns and practices; affirmative advertising, recruitment and training; technical assistance activities and such other reasonable activities or efforts as the commission may prescribe that are designed to ensure the participation of minority business enterprises in public works projects.

(e) The contractor shall develop and maintain adequate documentation, in a manner prescribed by the commission, of its good faith efforts.

- (f) The contractor shall include the provisions of sections (a) and (b) above in every subcontract or purchase order entered into in order to fulfill any obligation of a contract with the state and such provisions shall be binding on a subcontractor, vendor or manufacturer unless exempted by regulations or orders of the commission. The contractor shall take such action with respect to any such subcontract or purchase order as the commission may direct as a means of enforcing such provisions including sanctions for noncompliance in accordance with section 46a-56; provided, if such contractor becomes involved in, or is threatened with, litigation with a subcontractor or vendor as a result of such direction by the commission, the contractor may request the state of Connecticut to enter into any such litigation or negotiation prior thereto to protect the interests of the state and the state may so enter.
- (g) The following subsections are set forth here as required by section 4a-60a of the Connecticut General Statutes:
- (1) The contractor agrees and warrants that in the performance of the contract such contractor will not discriminate or permit discrimination against any person or group of persons on the grounds of sexual orientation, in any manner prohibited by the laws of the United States or of the state of Connecticut, and that employees are treated when employed without regard to their sexual orientation; (2) the contractor agrees to provide each labor union or representative of workers with which such contractor has a collective bargaining agreement or other contract or understanding and each vendor with which such contractor has a contract or understanding, a notice to be provided by the Commission on Human Rights and Opportunities advising the labor union or workers' representative of the contractor's commitments under this section, and to post copies of the notice in conspicuous places available to employees and applicants for employment; (3) the contractor agrees to comply with each provision of this section and with each regulation or relevant order issued by said commission pursuant to section 46a-56; and (4) the contractor agrees to provide the Commission on Human Rights and Opportunities with such information requested by the commission, and permit access to pertinent books, records and accounts, concerning the employment practices and procedures of the contractor which relate to the provisions of this section and section 46a-56.
- (h) The contractor shall include the provisions of section (g) above in every subcontract or purchase order entered into in order to fulfill any obligation of a contract with the state and such provisions shall be binding on a subcontractor, vendor or manufacturer unless exempted by regulations or orders of the commission. The contractor shall take such action with respect to any such subcontract or purchase order as the commission may direct as a means of enforcing such provisions including sanctions for noncompliance in accordance with section 46a-56; provided, if such contractor becomes involved in, or is threatened with, litigation with a subcontractor or vendor as a result of such direction by the commission, the contractor may request the state of Connecticut to enter into any such litigation or negotiation prior thereto to protect the interests of the state and the state may so enter.
- (i) For the purposes of this entire Non-Discrimination section, "contract" includes any extension or modification of the contract, "contractor" includes any successors or assigns of the contractor, "marital status" means being single, married as recognized by the state of Connecticut, widowed, separated or divorced, and "mental disability" means one or more mental disorders, as defined in the most recent edition of the American Psychiatric Association's "Diagnostic and Statistical Manual of Mental Disorders", or a record of or regarding a person as having one or more such disorders. For the purposes of this section, "contract" does not include a contract where each contractor is (1) a political subdivision of the state, including, but not limited to, a municipality, (2) a quasi-public agency, as defined in Conn. Gen. Stat. Section 1-120, (3) any other state, including but not limited to any federally recognized Indian tribal governments, as defined in Conn. Gen. Stat. Section 1-267, (4) the federal government, (5) a foreign government, or (6) an agency of a subdivision, agency, state or government described in the immediately preceding enumerated items (1), (2), (3), (4) or (5).

NONDISCRIMINATION (SEXUAL ORIENTATION)

(a) Pursuant to Section 4a-60a of the Connecticut General Statutes, (1) The contractor agrees and warrants that in the performance of the contract such Contractor will not discriminate or permit discrimination against any person or group of persons on the grounds of sexual orientation, in any manner prohibited by the laws of the United States or of the State of Connecticut, and that employees are treated when employed without regard to their sexual orientation; (2) the contractor agrees to provide each labor union or representative of workers with which such contractor has a collective bargaining agreement or other contract or understanding and each vendor with which such Contractor has a contract or understanding, a notice to be provided by the Commission on Human Rights and Opportunities advising the labor union or workers' representative of the Contractor's commitments under this section, and to post copies of the notice in conspicuous places available to employees and applicants for employment; (3) the contractor agrees to comply with each provision of this section and with each regulation or relevant order issued by said commission pursuant to section 46a-56 of the general statutes; (4) the contractor agrees to provide the commission on human rights and opportunities with such information requested by the commission, and permit access to pertinent books, records and accounts, concerning the employment practices and procedures of the Contractor which relate to the provisions of this section and section 46a-56 of the general statutes.

(b) The contractor shall include the provisions of subsection (a) of this section in every subcontract or purchase order entered into in order to fulfill any obligation of a contract with the state and such provisions shall be binding on a subcontractor, vendor or manufacturer unless exempted by regulations or orders of the commission. The contractor shall take such action with respect to any such subcontract or purchase order as the commission may direct as a means of enforcing such provisions including sanctions for noncompliance in accordance with section 46a-56 of the general statutes; provided, if such contractor becomes involved in, or is threatened with, litigation with a subcontractor or vendor as a result of such direction by the commission, the contractor may request the state of Connecticut to enter into any such litigation or negotiation prior thereto to protect the interest of the state and the state may so enter.

RESIDENTS' PREFERENCE IN WORK ON OTHER PUBLIC FACILITIES

The Contractor shall comply with the provisions of Section 31-52a of the General Statutes of the State of Connecticut, Revision of 1985, a part of which is quoted as follows:

(b) Each contract for any such project covered by this section under the supervision of the state or any of its agents shall contain the following provision: "In the employment of mechanics, laborers or workmen to perform the work specified herein, preference shall be given to residents of the state who are, and continuously for at least six months prior to the date hereof have been, residents of this state, and if no such person is available then to residents of other states."

CONSTRUCTION, ALTERATION OR REPAIR OF PUBLIC WORKS PROJECTS BY THE STATE OR POLITICAL SUBDIVISION

The contractor shall comply with the provisions of Section 31-53 of the General Statutes of the State of Connecticut, as revised, a part of which is quoted as follows:

(a) Each contract for the construction, remodeling, refinishing, refurbishing rehabilitation, alteration or repair of any public works project by the state or any of its agents, or by any political subdivision of the state or any of its agents, shall contain the following provision: "The wages paid on an hourly basis to any mechanic, laborer or workman employed upon the work herein contracted to be done and the amount of payment or contribution paid or payable on behalf of each such employee to any employee welfare fund, as defined in subsection (h) of this section, shall be at a rate equal to the rate customary or prevailing for the same work in the same trade or occupation in the town in which such public works project is being constructed. Any contractor who is not obligated by agreement to make payment or contribution on behalf of such employees to any such employee welfare fund shall pay to each employee as part of his wages the amount of payment or contribution for his classification on each pay day."

LIMITATION ON AWARDING OF CONTRACTS

The contractor shall comply with the provisions of Section 31-53a of the General Statutes of the State of Connecticut, as revised, a part of which is quoted as follows:

2) No general contractor that enters into a contract with the state or any of its agents, or with any political subdivision of the state or any of its agents, for the construction, remodeling, refinishing, refurbishing, rehabilitation, alteration or repair of any public works project subject to the provisions of section 31-53, as amended, or for any state highway project that falls under the provisions of section 31-54, shall award any work under such contract to the persons or firms appearing on the list distributed by the Labor Commissioner pursuant to subsection (a) of this section or to any firm, corporation, partnership or association in which such persons or firms have an interest until a period of up to three years, as determined by the Labor Commissioner, has elapsed from the date of publication of the list containing the names of such persons or firms.

(3) Prior to performing any work under a contract for the construction, remodeling, refinishing, refurbishing, rehabilitation, alteration or repair of any public works project subject to the provisions of section 31-53, as amended, or for any state highway project that falls under the provisions of section 31-54, each person, firm, corporation, partnership or association engaged by a general contractor to perform such work shall submit a sworn affidavit to the general contractor attesting that such person, firm, corporation, partnership or association does not hold an interest of ten per cent or greater in a firm appearing on the list distributed by the Labor Commissioner pursuant to subsection (a) of this section. The receipt and retention by a general contractor of such sworn affidavit shall fulfill the general contractor's obligation under subdivision (2) of this subsection.

RATE OF WAGES FOR WORK ON STATE HIGHWAYS

The contractor shall comply with the provisions of Section 31-54 of the General Statutes of the State of Connecticut, as revised, which is quoted as follows:

The Labor Commissioner shall hold a hearing at any required time to determine the prevailing rate of wages upon any highway contract within any specified area on an hourly basis and the amount of payment or contributions paid or payable on behalf of each employee to any employee welfare fund, as defined in section 31-53, upon any classifications of skilled, semiskilled and ordinary labor. Said commissioner shall determine the prevailing rate of wages on an hourly basis and the amount of payment or contributions paid or payable on behalf of each employee to any employee welfare fund, as defined in section 31-53, in each locality where any highway or bridge is to be constructed, and the Commissioner of Transportation shall include such rate of wage on an hourly basis and the amount of payment or contributions paid or payable on behalf of each employee to any employee welfare fund, as defined in section 31-53, or in lieu thereof, in cash as part of wages each pay day, for each classification of labor in the proposal for the contract and in the contract. The rate and the amount so established shall, at all times, be considered as the minimum rate of wage on an hourly basis and the amount of payment or contributions to an employee welfare fund, or cash in lieu thereof, for the classification for which it was established. Any contractor who pays any person at a lower rate of wage on an hourly basis or the amount of payment or contributions paid or payable on behalf of each employee to any employee welfare fund, as defined in section 31-53, or where he is not obligated by any agreement to make payment or contributions to the employee welfare funds, as defined in section 31-53, and fails to pay the amount of such payment or contributions directly to the employee as part of his wages each pay day, than that so established for the classifications of work specified in any such contract shall be fined not more than two hundred dollars for each offense. The provisions of this section shall apply only to state highways and bridges on state highways.

ANNUAL ADJUSTMENTS TO PREVAILING WAGES

The contractor shall comply with the provisions of Public Act 02-69 which reads, as follows:

Each contractor that is awarded a contract on or after October 1, 2002, for (1) the construction of a state highway or bridge that falls under the provisions of section 31-54 of the general statutes, or (2) the construction, remodeling, refinishing, refurbishing, rehabilitation, alteration or repair of any public works project that falls under the provision of section 31-53 of the general statutes shall contact the Labor Commissioner on or before July first of each year, for the duration of such contract, to ascertain the prevailing rate of wages on an hourly basis and the amount of payment or contributions paid or payable on behalf of each mechanic, laborer or worker employed upon the work contracted to be done, and shall make any necessary adjustments to such prevailing rate of wages and such payment or contributions paid or payable on behalf of each employee, effective each July first.

AWARDING OF CONTRACTS TO OCCUPATIONAL SAFETY AND HEALTH LAW VIOLATORS PROHIBITED

The contractor shall comply with the provisions of Section 31-57b of the General Statutes of the State of Connecticut, as revised, which is quoted as follows:

No contract shall be awarded by the State or any of its political subdivisions to any person or firm or any firm, corporation, partnership or association in which such persons or firms have an interest (1) which has been cited for three or more wilful or serious violations of any occupational safety and health act or of any standard, order or regulation promulgated pursuant to such act, during the three-year period preceding the bid, provided such violations were cited in accordance with the provisions of any state occupational safety and health act or the Occupational Safety and Health Act of 1970, and not abated within the time fixed by the citation and such citation has not been set aside following appeal to the appropriate agency or court having jurisdiction or (2) which has received one or more criminal convictions related to the injury or death of any employee in the three-year period preceding the bid. Any person who knowingly provides false information concerning the information required pursuant to this section shall be assessed a civil penalty of not less than five hundred dollars nor more than five thousand dollars and shall be disqualified from bidding on or participating in a contract with the state or any of its political subdivisions for five years

from the date of the final determination that the information is false. Any political subdivision or any state agency receiving false information pursuant to this section shall notify the Commissioner of Administrative Services and, upon receipt of such notice, the commissioner shall conduct a hearing in accordance with the provisions of chapter 54. Upon a determination that false information was provided, the commissioner shall impose a civil penalty in accordance with the provisions of this section. Such civil penalty shall be paid to the Treasurer or to an official of the political subdivision, as the case may be. Any civil penalty imposed pursuant to this section may be collected in a civil proceeding by any official of a political subdivision authorized to institute civil actions or, in the case of the state, by the attorney general, upon complaint of the Commissioner of Administrative Services.

CONSTRUCTION SAFETY AND HEALTH STANDARDS

It is a condition of this contract, and shall be made a condition of each subcontract entered into pursuant to this contract, that the contractor and any subcontractor shall not require any laborer or mechanic employed in performance of the contract to work in surroundings or under working conditions which are unsanitary, hazardous, or dangerous to his health or safety, as determined under construction safety and health standards (Title 29, Code of Federal Regulations, Part 1926, formerly Part 1518, as revised from time to time), promulgated by the United States Secretary of Labor, in accordance with Section 107 of the Contract Work Hours and Safety Standards Act (83 Stat. 96).

SERVICE OF PROCESS

The successful bidder, if not a resident of the State of Connecticut, or, in the case of a partnership, the partners, if not residents, hereby appoints the Secretary of State of the State of Connecticut, and his successors in office as agent for service of process for any action arising out of or as a result of this Contract; such appointment to be in effect throughout the life of this Contract, and six (6) years thereafter.

AMERICANS WITH DISABILITIES ACT OF 1990

This clause applies to those contractors who are or will be responsible for compliance with the terms of the Americans with Disabilities Act of 1990, (42 U.S.C. 12101 et seq.), (Act), during the term of the contract. The contractor represents that it is familiar with the terms of this Act and that it is in compliance with the Act. Failure of the contractor to satisfy this standard as the same applies to performance under this contract, either now or during the term of the contract as it may be amended, will render the contract voidable at the option of the State upon notice to the contractor. The contractor warrants that it will hold the State harmless and indemnify the State from any liability which may be imposed upon the State as a result of any failure of the contractor to be in compliance with this Act, as the same applies to performance under this contract.

EXECUTIVE ORDER NO. THREE

This contract is subject to the provisions of Executive Order No. Three of Governor Thomas J. Meskill promulgated June 16, 1971 and, as such, this contract may be cancelled, terminated or suspended by the State Labor Commissioner for violation of, or noncompliance with said Executive Order No. Three, or any state or federal law concerning nondiscrimination, notwithstanding that the Labor Commissioner is not a party to this contract. The parties to this contract as part of the consideration hereof, agree that Executive Order No. Three is incorporated herein by reference and made a part hereof. The parties agree to abide by said Executive Order and agree that the State Labor Commissioner shall have continuing jurisdiction in respect to contract performance in regard to nondiscrimination, until the contract is completed or terminated prior to completion.

EXECUTIVE ORDER 7C

This provision and its subsections are included in this contract in accordance with Section 6 of Governor M. Jodi Rell's Executive Order No. 7C: The State Contracting Standards Board (the "Board") may review the contract and recommend to the state contracting agency termination of the contract for cause. For the purpose of this Section, "for cause" means: (1) a violation of the State Ethics Code (Chapter 10 of the general statutes) or section 4a-100 of the general statutes or (2) wanton or reckless disregard of any state contracting and procurement process by any person substantially involved in such contract or state contracting agency. The Board shall provide the results of its review, together with its recommendations, to the state contracting agency and any other affected party in accordance with the notice provisions in the contract no later than fifteen (15) days after the Board finalizes its recommendation. The state contracting agency shall consider the recommendations of the Board and act in accordance with the contract and applicable law.

The contractor agrees to satisfy the requirements of Executive Order 1 and Section 10(a) of Executive Order No. 7C of Governor M. Jodi Rell and § 4-252 of the Connecticut General Statutes, as amended, including the delivery of the certification of the contractor with respect to gifts and lawful campaign contributions and other matters required thereunder, which form of certificate is available on the Website of the Office of Policy and Management at www.opm.state.ct.us. If this is a multi-year contract, then, so long as the contract remains in effect, the contractor shall provide the State with an annual update of the aforesaid certification on each anniversary of the effective date of such contract.

EXECUTIVE ORDER NO. 14

When applicable, this contract is subject to the provisions of Executive Order No. 14 of Governor M. Jodi Rell promulgated April 17, 2007 and, as such, the contract may be canceled, terminated or suspended by the state for violation of or noncompliance with said Executive Order 14. The parties to this contract, as part of the consideration hereof, agree that said Executive Order No. 14 is incorporated herein by reference and made a part hereof. This Executive Order No. 14 shall be made a part of any applicable subcontracts to this Agreement. The parties agree to abide by such Executive Order.

EXECUTIVE ORDER NO. 16/VIOLENCE IN THE WORKPLACE PREVENTION

This contract is subject to the provisions of Executive Order No. 16 of Governor John G. Rowland promulgated August 4, 1999 and, as such, the contract may be canceled, terminated or suspended by the state for violation of or noncompliance with said Executive Order No. 16. The parties to this contract, as part of the consideration hereof, agree that said Executive Order No. 16 is incorporated herein by reference and made a part hereof. The parties agree to abide by such Executive Order.

EXECUTIVE ORDER NO. SEVENTEEN/LISTING ALL EMPLOYMENT OPENINGS WITH THE CONNECTICUT STATE EMPLOYMENT SERVICE

This contract is subject to the provisions of Executive Order No. Seventeen of Governor Thomas J. Meskill promulgated February 15, 1973, and, as such, this contract may be cancelled, terminated or suspended by the contracting agency or the State Labor Commissioner for violation of or noncompliance with said Executive Order No. Seventeen, notwithstanding that the Labor Commissioner may not be a party to this contract. The parties to this contract, as part of the consideration hereof, agree that Executive Order No. Seventeen is incorporated herein by reference and made a part hereof. The parties agree to abide by said Executive Order and agree that the contracting agency and the State Labor Commissioner shall have joint and several continuing jurisdiction in respect to contract performance in regard to listing all employment openings with the Connecticut State Employment Service.

EXECUTIVE ORDER NO. 18

When applicable, this contract is subject to the provisions of Executive Order No. 18 of Governor M. Jodi Rell dated February 6, 2008 and, as such, the contract may be canceled, terminated or suspended by the state for violation of or noncompliance with said Executive Order 18. The parties to this contract, as part of the consideration hereof, agree that said Executive Order No. 18 is incorporated herein by reference and made a part hereof. This Executive Order No. 18 shall be made a part of any applicable subcontracts to this Agreement. The parties agree to abide by such Executive Order.

CONNECTICUT REQUIRED CONTRACT/AGREEMENT PROVISIONS

The contractor hereby acknowledges and agrees to comply with the attached CONNECTICUT REQUIRED CONTRACT/AGREEMENT PROVISIONS entitled "Specific Equal Employment Opportunity Responsibilities", dated March 3, 2009, a copy of which is attached hereto and made a part of hereof.

A(76) AFFIRMATIVE ACTION REQUIREMENTS A (76)

It is the intent of these Affirmative Action Requirements to provide compliance standards for employee-hours in each craft utilized in the transportation construction industry on transportation construction projects. This provision affects contractors and their subcontractors while under contract with the Connecticut Department of Transportation. It is not the intent of these Affirmative Action Requirements to cause personnel displacement in order to hire qualified minorities and women. They are however designed to ensure that equal employment opportunity is being provided and discriminatory employment practices are not being exercised. The actual number of minority and female employee hours worked in each craft, compared to the labor market goals, will determine project compliance.

General Contract Provision

The contractor or subcontractor shall comply with this provision or provide adequate documentation of "good faith efforts" in attempting to comply with this provision.

The employee hours for minorities and females should be substantially uniform throughout the length of the contract for each of the trades. The time-table for meeting the project goals extends through the duration of the contract.

For the purpose of this provision, "minority" is defined as; Blacks, includes all persons having origins in any of the black racial groups; Hispanics, includes all persons of Mexican, Puerto Rican, Cuban, Central or South American, or Spanish Culture, except Portuguese; Asians, includes all persons having origins in any of the original peoples of the Far East, Southeast Asia, or Pacific Islands; and American Indians, all persons having origins in any of the original peoples of North America.

The percentage goals for minority employee-hour utilization and female employee hour utilization are based on Connecticut Labor Market statistics. The labor market goals for minorities and females are separate goals. Employees should not be counted in both the minority and female categories. The goal requirements are listed in Appendix A of this provision. The employee-hour percentages are expressed in terms of training and employment hours in proportion to the total employee-hours worked by the contractor's and/or subcontractor's entire work force in that trade or craft. The transfer of minorities, females or trainees from employer to employer, or from project to project, for the sole purpose of meeting the labor market goal, is a violation of this contract provision.

In no event may a contractor or subcontractor utilize the goals, time-tables, or affirmative action steps, required by these provisions in such a manner as to cause or result in discrimination against any person on the basis of race, color, religion, sex, age, marital status, national origin, ancestry, present or past history of mental disorder, mental retardation, learning disability or physical disability, including, but not limited to, blindness.

Compliance and Enforcement

Contractors are responsible for informing their subcontractor(s) (regardless of tier) as to their respective obligations under these provisions. Any contractor or subcontractor who fails to meet the stipulation(s) prescribed in this provision, and/or fails to provide adequate documentation of affirmative actions and "good faith efforts", shall be deemed to be in noncompliance with this provision, as well as; Presidential Executive Order 11246 as amended, the Governor's Executive Order #3, Connecticut's EEO Special Provisions and Equal Opportunity Clause of its contract.

If the contractor and/or subcontractor is deemed to be in non-compliance, then he shall be subject to sanctions and penalties for violation of Connecticut's Specific Equal Employment Opportunity Responsibilities Contract Provision (April 1994), Presidential Executive Order 11246 as amended and/or the Governor's Executive Order #3. These sanctions and penalties shall include but not be limited to suspension, termination, and/or cancellation of existing contracts and/or subcontracts (subcontract agreements).

Procedures

In determining whether a contractor or subcontractor has met the goals, the agency will consider the contractor's and/or subcontractor's utilization of minority and female participation per craft (hourly). If the contractor or subcontractor meets the goals, or can demonstrate and document that every good faith effort was made to meet the goals, the contractor or subcontractor shall be presumed to be in compliance with this contract provision. Formal sanctions or proceedings will not be instituted unless the agency otherwise determines that the contractor or subcontractor is in violation of this provision.

In the event a noncompliance finding is made, the contractor shall receive an informal letter informing him/her of the noncompliance finding and a request for corrective action relative to this finding. If no response is received, or if the response is unsatisfactory, the contractor shall receive a registered show-cause notice requesting specific action to be taken by the contractor, and an explanation of what actions may be taken against the contractor if a satisfactory solution is not reached.

If a show cause notice is issued, then the formal process begins, and proceeds with such formal actions as prescribed by the sanctions and penalties described herein; the burden of proving the

noncompliance of these provisions lies with the agency. However, the contractor's or subcontractor's failure to meet his goals shall shift to him to present evidence to show that he has met the "good faith effort" requirement of these provisions.

In respect to matters not covered in this provision, nothing herein is intended to relieve any contractor or subcontractor from compliance with all applicable federal and state laws, regulations, Executive Orders and/or Special Provisions concerning equal employment opportunity, affirmative action, nondiscrimination and related subjects during the term of its contract on this project.

Records and Reports

It is required of the successful bidder and each approved subcontractor to submit to the Division of Contract Compliance for review and approval an affirmative action plan. On federal-aid projects, this requirement (Affirmative Action Plan) is waived if the contract or subcontract is under \$10,000 (unless an Affirmative Action Plan is determined necessary by the contracting agency). On completely state-funded projects, the Affirmative Action Plan requirement is waived on contracts or subcontracts under \$5,000 (unless an Affirmative Action Plan is determined necessary by the contracting agency).

This provision will supplement Connecticut's Required Contract Provision, entitled "Specific Equal Employment Opportunity Responsibilities" in all contracts including federally-aided contracts as applicable.

APPENDIX A
(LABOR MARKET GOALS)

<u>LABOR MARKET AREA GOAL</u>	<u>% MINORITY GOAL</u>	<u>% FEMALE</u>
Bridgeport Ansonia-Beacon Falls-Bridgeport- Derby-Easton-Fairfield-Milford- Monroe-Oxford-Seymour-Shelton- Stratford-Trumbull	14	6.9
Danbury Bethel-Bridgewater-Brookfield- Danbury-Kent-New Fairfield- New Milford-Newtown-Redding- Ridgefield-Roxbury-Sherman- Washington	4	6.9
Danielson Brooklyn-Eastford-Hampton- Killingly-Pomfret-Putnam- Scotland-Sterling-Thompson- Voluntown-Union-Woodstock	2	6.9
Hartford Andover-Ashford-Avon-Barkhamsted- Berlin-Bloomfield-Bolton-Bristol- Burlington-Canton-Chaplin- Colchester-Columbia-Coventry- Cromwell-Durham-East Granby- East Haddam-East Hampton- East Hartford-East Windsor- Ellington-Enfield-Farmington- Glastonbury-Granby-Haddam- Hartford-Harwington-Hebron- Lebanon-Manchester-Mansfield- Marlborough-Middlefield-Middletown- Newington-Plainville-Plymouth- Portland-Rocky Hill-Simsbury-Somers- South Windsor-Southington-Stafford- Suffield-Tolland-Vernon- West Hartford-Wethersfield-Willington- Winchester-Windham-Windsor- Windsor Locks	15	6.9
Lower River Chester-Deep River-Essex-Lyme- Westbrook	2	6.9

<u>LABOR MARKET AREA GOAL</u>	<u>% MINORITY GOAL</u>	<u>% FEMALE</u>
New Haven Bethany-Branford-Cheshire- Clinton-East Haven-Guilford- Hamden-Killingworth-Madison- Meriden-New Haven-No.Branford- North Haven-Orange-Wallingford- West Haven-Woodbridge	14	6.9
New London Bozrah-Canterbury-East Lyme- Franklin-Griswold-Groton- Ledyard-Lisbon-Montville- New London-North Stonington- Norwich-Old Lyme-Old Saybrook- Plainfield-Preston-Salem- Sprague-Stonington-Waterford- Hopkinton RI-Westerly RI	8	6.9
Stamford Darien-Greenwich-New Canaan- Norwalk-Stamford-Weston- Westport-Wilton	17	6.9
Torrington Canaan-Colebrook- Cornwall-Goshen-Hartland-Kent- Litchfield-Morris- Norfolk-North Canaan-Salisbury- Sharon-Torrington-Warren	2	6.9
Waterbury Bethlehem-Middlebury-Naugatuck- Prospect-Southbury-Thomaston- Waterbury-Watertown-Wolcott- Woodbur	10	6.9

Privatized Public Records

If applicable, the Department is entitled to receive a copy of records and files related to the performance of the Contractor under this Construction Contract, and such records and files shall be subject to the Freedom of Information Act and may be disclosed by the Department pursuant to the Freedom of Information Act. No request to inspect or copy such records or files shall be valid unless the request is made to the Department in accordance with the Freedom of Information Act. Any complaint by a person who is denied the right to inspect or copy such records or files shall be brought to the Freedom of Information Commission in accordance with the provisions of Section 1-205 and 1-206 of the Connecticut General Statutes.

The terminology "If applicable," precedes the language above to account for any construction contracts initially having a value of less than Two Million Five Hundred Thousand Dollars (\$2,500,000), but having the potential, through change orders, to exceed the cited threshold.

Oversight of Large State Contracts

The following clause is applicable to those contracts with an aggregate value of Five Million Dollars (\$5,000,000) or more.

If an officer, employee or appointing authority of the contractor takes or threatens to take any personnel action against any employee of the contractor in retaliation for such employee's disclosure of information to any employee of the state or quasi-public agency (if applicable) or the Auditors of Public Accounts or the Attorney General under the provisions of Connecticut General Statutes Section 4-61dd(a), the for a civil penalty of not more than Five Thousand Dollars for each offense, up to a maximum of twenty percent of the value of the contract. Each violation shall be a separate and distinct offense and in contractor shall be liable the case of a continuing violation each calendar day's continuance of the violation shall be deemed to be a separate and distinct offense. The executive head of the state or quasi-public agency (if applicable) may request the Attorney General to bring a civil action in the superior court for the judicial district of Hartford to seek imposition and recovery of such civil penalty.

The contractor shall post a notice of the provisions of this section in a conspicuous place which is readily available for viewing by the employees of the Contractor.

Construction Safety and Health Course

The contractor shall comply with the provisions of section 31-53b of the General Statutes of the State of Connecticut as revised which is quoted as follows.

(a) Each contract entered into on or after July 1, 2007, for the construction, remodeling, refinishing, refurbishing, rehabilitation, alteration or repair of any public building project by the state or any of its agents, or by any political subdivision of the state or any of its agents, where the total cost of all work to be performed by all contractors and subcontractors in connection with the contract is at least one hundred thousand dollars, shall contain a provision requiring that, not later than thirty days after the date such contract is awarded, each contractor furnish proof to the Labor Commissioner that all employees performing manual labor on or in such public building, pursuant to such contract, have completed a course of at least ten hours in duration in construction safety and health approved by the federal Occupational Safety and Health Administration or, in the case of telecommunications employees, have completed at least ten hours of training in accordance with 29 CFR 1910.268.

(b) Any employee required to complete a construction safety and health course required under subsection (a) of this section who has not completed the course shall be subject to removal from the worksite if the employee does not provide documentation of having completed such course by the fifteenth day after the date the employee is found to be in noncompliance. The Labor Commissioner's designee shall enforce this section.

(c) Not later than January 1, 2007, the Labor Commissioner shall adopt regulations, in accordance with the provisions of chapter 54 of the general statutes, to implement the provisions of subsections (a) and (b) of this section. Such regulations shall require that the ten-hour construction safety and health courses required under subsection (a) of this section be conducted in accordance with federal Occupational Safety and Health Administration Training Institute standards, or in accordance with 29 CFR 1910.268, as appropriate. The Labor Commissioner shall accept as sufficient proof of compliance with the provisions of subsection (a) or (b) of this section a student course completion card issued by the federal Occupational Safety and Health Administration

Training Institute, or such other proof of compliance said commissioner deems appropriate, dated no earlier than five years before the commencement date of such public works project.

(d) For the purposes of this section, "public building" means a structure, paid for in whole or in part with state funds, within a roof and within exterior walls or fire walls, designed for the housing, shelter, enclosure and support or employment of people, animals or property of any kind, including, but not limited to, sewage treatment plants and water treatment plants. "Public Building" does not include site work, roads or bridges, rail lines, parking lots or underground water, sewer or drainage systems including pump houses or other utility systems.

CIVIL RIGHTS REVISIONS - TITLE VI CONTRACTOR ASSURANCE

As a condition to receiving federal financial assistance under the Contract, if any, the contractor shall comply with Title VI of the Civil Rights Act of 1964 (42 U.S.C. 2000 et seq.) all requirements imposed by the regulations of the United States Department of Transportation (49 CFR Part 21) issued in implementation thereof, and the Title VI Contractor Assurances attached hereto, all of which are hereby made a part of this Contract.

CONNECTICUT

REQUIRED CONTRACT PROVISION

STANDARD FEDERAL EQUAL EMPLOYMENT OPPORTUNITY

CONSTRUCTION CONTRACT SPECIFICATION

(EXECUTIVE ORDER 11246)

1. Appendix A and Appendix B referred to below and attached hereto express goals and timetables for the utilization of females and minorities respectively on all federally assisted construction projects advertised by the Connecticut Department of Transportation.

Appendix A establishes the goal for female utilization in all crafts statewide. Appendix B refers to minority utilization for each trade in designated areas.

2. The goals for minority and female participation, expressed in percentage terms for the contractor's aggregate workforce in each trade on all construction work in the covered area, are as follows:

FEMALES

MINORITIES

See Appendix A

See Appendix B

These goals are applicable to all the Contractor's construction work (whether or not it is Federal or Federally assisted) performed in the covered area. If the contractor performs construction work in a geographical area located outside of the covered area, it shall apply the goals established for such geographical area where the work is actually performed. With regard to this second area, the contractor also is subject to the goals for both its federally involved and non-federally involved construction.

3. The Contractor's compliance with the Executive Order and the regulations in 41-CFR Part 60-4 shall be based on its implementation of the specific affirmative action obligations required by the specifications set forth in 41 CFR 60-4.3 (a) and its efforts to meet the goals established for the geographical area where the contract is to be performed. The hours of minority and female employment and training must be substantially uniform throughout the length of the contract, and in each trade, and the contractor shall make a good faith effort to employ minorities and women evenly on each of its projects. The transfer of minority or female employees or trainees from contractor to contractor or from project to project for the sole purpose of meeting the contractor's goals shall be a violation of the contract, the Executive Order and the regulations in 41 CFR Part 60-4. Compliance with the goals will be measured against the total work hours performed.

4. As used in these specifications:
 - a. "Covered area," means the geographical area described in the solicitation from which this contract resulted.
 - b. "Director" means Director, Office of Federal Contract Compliance Programs, United States Department of Labor, or any persons to whom the Director delegates authority.
 - c. "Employer Identification Number" means the Federal Social Security number used on the Employer's Quarterly Federal Tax Return, U.S. Treasury Department Form 941.
 - d. "Minority" includes:
 1. Black (all persons having origins in any of the Black African racial groups not of Hispanic origin):
 2. Hispanic (all persons of Mexican, Puerto Rican, Cuban, Central or South American or other Spanish Culture or Origin, regardless of race):
 3. Asian or Pacific Islander (all persons having origins in any of the original peoples of the Far East, Southeast Asia, the Indian Subcontinent, or the Pacific Islands: and
 4. American Indian or Alaskan Native (all persons having origins in any of the original peoples of North America and maintaining identifiable tribal affiliations through membership and participation or community identification).
5. Whenever the Contractor, or any Subcontractor at any tier, subcontracts a portion of the work involving any construction trade, it shall physically include in each subcontract in excess of \$10,000 the provisions of these specifications which contain the applicable goals for minority and female participation.
6. If the Contractor is participating (pursuant to 41 CFR 60-4.5) in a Hometown Plan approved by the U.S. Department of Labor in the covered area either individually or through an association, its affirmative action obligations on all work in the Plan area (including goals and timetables) shall be in accordance with that plan for those trades which have unions participating in the Plan. Contractors must be able to demonstrate their participation in and compliance with the provisions of any such Hometown Plan. Each Contractor or subcontractor participating in an approved Plan is individually required to comply with its obligations under the EEO clause, and to make a good faith effort to achieve each goal under the Plan in each trade in which it has employees. The overall good faith performance by other Contractors or subcontractors toward a goal in an approved Plan does not excuse any covered Contractor's or subcontractor's failure to take good faith efforts to achieve the plan goals and timetables.

7. The Contractor shall implement the specific affirmative action standards provided in paragraphs 10a through p of these specifications. The goals set forth in the solicitation from which this contract resulted are expressed as percentages of the total hours of employment and training of minority and female utilization the Contractor should reasonably be able to achieve in each construction trade in which it has employees in the covered area. Covered Construction contractors performing construction work in geographical areas where they do not have a federal or federally assisted construction contract shall apply the minority and female goals established for the geographical area where the work is being performed. Goals are published periodically in the Federal Register in notice form and such notices may be obtained from any Office of Federal Contract Compliance Programs (OFCCP) Office or from Federal procurement contracting officers. The Contractor is expected to make substantially uniform progress in meeting its goals in each craft during the period specified.
8. Neither the provisions of any collective bargaining agreement, nor the failure by a union with whom the Contractor has a collective bargaining agreement, to refer either minorities or women shall excuse the Contractor's obligations under these specifications, Executive Order 11246, or the regulations promulgated pursuant thereto.
9. In order for the nonworking training hours of apprentices and trainees to be counted in meeting the goals, such apprentices and trainees must be employed by the Contractor during the training period, and the Contractor must have made a commitment to employ the apprentices and trainees at the completion of their training, subject to training programs approved by the U.S. Department of Labor.
10. The Contractor shall take specific affirmative actions to ensure equal employment opportunity. The evaluation of the Contractor's compliance with these specifications shall be based upon its effort to achieve maximum results from its actions. The Contractor shall document these efforts fully, and shall implement affirmative action steps at least as extensive as the following:
 - a. Ensure and maintain a working environment free of harassment, intimidation, and coercion at all sites, and in all facilities at which the Contractor's employees are assigned to work. The Contractor, where possible, will assign two or more women to each construction project. The Contractor shall specifically ensure that all foremen, superintendents, and other onsite supervisory personnel are aware of and carry out the Contractor's obligation to maintain such a working environment, with specific attention to minority or female individuals working at such sites or in such facilities:
 - b. Establish and maintain a current list of minority and female recruitment sources, provide written notification to minority and female recruitment sources and to community organizations when the Contractor or its unions have employment opportunities available, and maintain a record of the organizations' responses.

- c. Maintain a current file of the names, addresses and telephone numbers of each minority and female of the street applicant and minority or female referral from a union, a recruitment source or community organization and of what action was taken with respect to each such individual. If such individual was sent to the union hiring hall for referral and was not referred back to the Contractor by the union or, if referred, not employed by the Contractor, this shall be documented in the file with the reason therefore, along with whatever additional actions the Contractor may have taken.
- d. Provide immediate notification to the Director when the Union or Unions with which the Contractor has a collective bargaining agreement has not been referred to the Contractor a minority person or woman sent by the Contractor, or when the Contractor has other information that the Union referral process has impeded the Contractor's efforts to meet its own obligations.
- e. Develop on the job training opportunities and/or participate in training programs for the area which expressly include minorities and women, including upgrading programs and apprenticeship and trainee programs relevant to the Contractor's employment needs, especially those programs funded or approved by the Department of Labor. The Contractor shall provide notice of these programs to the sources compiled under 10b above.
- f. Disseminate the Contractor's EEO policy by providing notice of the policy to unions and training programs and requesting their cooperation in assisting the Contractor in meeting its EEO obligations; by including it in any policy manual and collective bargaining agreement; by publicizing it in the company newspaper, annual report, etc.; by specific review of the policy with all management personnel and with all minority and female employees at least once a year; and by posting the company EEO Policy on bulletin boards accessible to all employees at each location where construction work is performed.
- g. Review, at least annually, the company's EEO policy and affirmative action obligations under these specifications with all employees having any responsibility for hiring, assignment, layoff, termination or other employment, decisions including specific review of these items with onsite supervisory personnel such as Superintendents, General Foreman, etc. prior to the initiation of construction work at any job site. A written record shall be made and maintained identifying the time and place of these meetings, persons attending, subject matter discussed and disposition of the subject matter.
- h. Disseminate the Contractor's EEO policy externally by including it in any advertising in the news media, specifically including minority and female news media, and providing written notification to and discussing the Contractor's EEO Policy with other Contractors and

Subcontractors with whom the Contractor does or anticipates doing business.

- i. Direct its recruitment efforts, both oral and written, to minority female and community organizations, to school with minority and female students and to minority and female recruitment and training organizations serving the Contractor's recruitment area and employment needs. Not later than one month prior to the date for the acceptance of applications for apprenticeship or other training by any recruitment source, the Contractor shall send written notification to organizations such as the above, describing the openings, screening procedures, and tests to be used in the selection process.
 - j. Encourage present minority and female employees to recruit other minority persons and women and, where reasonable, provide after school, summer and vacation employment to minority and female youth both on the site and in other areas of a Contractor's workforce..
 - k. Validate all tests and other selection requirements where there is an obligation to do so under 41 CFR Part 60-3.
 - l. Conduct, at least annually, an inventory and evaluation at least of all minority and female personnel for promotional opportunities and encourage these employees to seek or to prepare for, through appropriate training, etc., such opportunities.
 - m. Ensure that minority practices, job classifications, work assignments and other personnel practices, do not have a discriminatory effect by continually monitoring all personnel and employment related activities to ensure that the EEO policy and the Contractor's obligations under these specifications are being carried out.
 - n. Ensure that all facilities and company activities are nonsegregated except that separate or single user toilet and necessary changing facilities shall be provided to assure privacy between the sexes.
 - o. Document and maintain a record of all solicitations of offers for subcontractors from minority and female construction contractors and suppliers, including circulation of solicitation to minority and female contractor associations and other business associations.
 - p. Conduct a review, at least annually of all supervisors' adherence to and performance under the Contractor's EEO policies and affirmative action obligations.
11. Contractors are encouraged to participate in voluntary associations which assist in fulfilling one or more of their affirmative action obligations (10 a through p). The efforts of a contractor association, joint contractor union, contractor community, or other similar group of which the contractor is a member and participant, may

be associated as fulfilling any one or more of its obligations under 10 a through p of these Specifications provided that the contractor actively participates in the group, makes every effort to assure that the group has a positive impact on the employment of minorities and women in the industry, ensures that the concrete benefits of the program are reflected in the Contractor's minority and female workforce participation, makes a good faith effort to meet its individual goals and timetables, and can provide access to documentation which demonstrates the effectiveness of actions taken on behalf of the Contractor. The obligations to comply, however, is the Contractor's and failure of such a group to fulfill an obligation shall not be a defense for the Contractor's noncompliance.

12. A single goal for minorities and separate single goal for women have been established. The Contractor, however, is required to provide equal employment opportunity and to take affirmative action for all minority groups, both male and female, and all women, both minority and not-minority. Consequently, the Contractor may be in violation of the Executive Order if a particular group is employed in a substantially disparate manner (for example, even though the Contractor has achieved its goals for women generally, the Contractor may be in violation of the Executive Order if a specific minority group of women is underutilized).
13. The contractor shall not use the goals and timetables or affirmative action standards to discriminate against any person because of race, color, religion, sex or national origin.
14. The contractor shall not enter into any Subcontract with any person or firm debarred from Government contracts pursuant to Executive Order 11246.
15. The Contractor shall carry out such sanctions and penalties for violations of these specifications and of the Equal Opportunity Clause, including suspension, termination and cancellation of existing subcontracts as may be imposed or ordered pursuant to Executive Order 11246, as amended, and its implementing regulations by the Office of Federal Contract Compliance Programs. Any Contractor who fails to carry out such sanctions and penalties shall be in violation of these specifications and Executive Order 112646, as amended.
16. The Contractor, in fulfilling its obligations under these specifications, shall implement specific affirmative action steps, at least as extensive as those standards prescribed in paragraph 10 of these specifications, so as to achieve maximum results from its efforts to ensure equal employment opportunity. If the Contractor fails to comply with the requirements of the Executive Order, the implementing regulations, or these specifications, the Director shall proceed in compliance with 41 CFR 60-4.8.
17. The Contractor shall designate a responsible official to monitor all employment related activities to ensure that the company EEO policy is being carried out, to submit reports relating to the provisions hereof as may be required by the Government and to keep records. Records shall at least include for each employee the name, address, telephone numbers, construction trade, union affiliation if any,

employee identification number when assigned, social security number, race, sex, status, (e.g. mechanic, apprentice, trainee, helper, or laborer), dates of changes in statuses, hours worked per week in the indicated trade, rate of pay, and locations at which the work was performed. Records shall be maintained in an easily understandable and retrievable form; however, to the degree that existing records satisfy this requirement, contractors shall not be required to maintain separate records.

18. Nothing herein provided shall be construed as a limitation upon the application of their laws which establish different standards of compliance or upon the application of requirements for the hiring of local or other area residents (e.g. those under the Public Works Employment Act of 1977 and the Community Development Black Grant Program.)
19. The Director of the Office of Federal Contract Compliance Program, from time to time, shall issued goals and timetables for minority and female utilization which shall be based on appropriate workforces, demographic or other relevant date and which shall cover construction projects or construction contracts performed in specific geographical areas. The goals, which shall be applicable to each construction trade in a covered contractor's or subcontractor's entire workforce which is working in the area covered by the goals and timetables, shall be published as notices in the Federal Register, and shall be inserted by the contracting officers and applicants, as applicable, in the Notice required by 41 C.F.R. 60-4.2. Covered construction contractors performing construction work in geographical areas where they do not have a Federal or federally assisted construction contract shall apply the minority and female goals established for the geographical areas where the work is being performed.

APPENDIX A and B

Until further notice, the following goals for minority utilization in each construction craft and trade shall be included in all Federal or federally assisted construction contracts and subcontracts in excess of \$10,000 to be performed in the respective geographical areas. The goals are applicable to each nonexempt contractor's total on-site construction work-force, regardless of whether or not part of that work-force is performing work on Federal, federally assisted or non-federally related project, contract or subcontract.

To be used for Federal-aid contracts

GOALS

<u>Standard Metropolitan Statistical Area (SMSA)</u>				<u>Minority</u>	<u>Female</u>
Bridgeport – Stamford – Norwalk – Danbury				10.2%	6.9%
<i>Bethel</i>	<i>Bridgeport</i>	<i>Brookfield</i>	<i>Danbury</i>		
<i>Darien</i>	<i>Derby</i>	<i>Easton</i>	<i>Fairfield</i>		
<i>Greenwich</i>	<i>Milford</i>	<i>Monroe</i>	<i>New Canaan</i>		
<i>New Fairfield</i>	<i>Newtown</i>	<i>Norwalk</i>	<i>Redding</i>		
<i>Shelton</i>	<i>Stamford</i>	<i>Stratford</i>	<i>Trumbull</i>		
<i>Weston</i>	<i>Westport</i>	<i>Wilton</i>			
Hartford – Bristol – New Britain				6.9%	6.9%
<i>Andover</i>	<i>Avon</i>	<i>Berlin</i>	<i>Bloomfield</i>		
<i>Bolton</i>	<i>Bristol</i>	<i>Burlington</i>	<i>Canton</i>		
<i>Colchester</i>	<i>Columbia</i>	<i>Coventry</i>	<i>Cromwell</i>		
<i>East Granby</i>	<i>East Hampton</i>	<i>East Hartford</i>	<i>East Windsor</i>		
<i>Ellington</i>	<i>Enfield</i>	<i>Farmington</i>	<i>Glastonbury</i>		
<i>Granby</i>	<i>Hartford</i>	<i>Hebron</i>	<i>Manchester</i>		
<i>Marlborough</i>	<i>New Britain</i>	<i>New Hartford</i>	<i>Newington</i>		
<i>Plainville</i>	<i>Plymouth</i>	<i>Portland</i>	<i>Rocky Hill</i>		
<i>Simsbury</i>	<i>South Windsor</i>	<i>Southington</i>	<i>Stafford</i>		
<i>Suffield</i>	<i>Tolland</i>	<i>Vernon</i>	<i>West Hartford</i>		
<i>Wethersfield</i>	<i>Willington</i>	<i>Windsor</i>	<i>Windsor Locks</i>		
New Haven – Waterbury – Meriden				9.0%	6.9%
<i>Beacon Falls</i>	<i>Bethany</i>	<i>Branford</i>	<i>Cheshire</i>		
<i>Clinton</i>	<i>East Haven</i>	<i>Guilford</i>	<i>Hamden</i>		
<i>Madison</i>	<i>Meriden</i>	<i>Middlebury</i>	<i>Naugatuck</i>		
<i>New Haven</i>	<i>North Branford</i>	<i>North Haven</i>	<i>Orange</i>		
<i>Prospect</i>	<i>Southbury</i>	<i>Thomaston</i>	<i>Wallingford</i>		
<i>Waterbury</i>	<i>Watertown</i>	<i>West Haven</i>	<i>Wolcott</i>		
<i>Woodbridge</i>	<i>Woodbury</i>				

New London – Norwich				4.5%	6.9%
<i>Bozrah</i>	<i>East Lyme</i>	<i>Griswold</i>	<i>Groton</i>		
<i>Ledyard</i>	<i>Lisbon</i>	<i>Montville</i>	<i>New London</i>		
<i>Norwich</i>	<i>Old Lyme</i>	<i>Old Saybrook</i>	<i>Preston</i>		
<i>Sprague</i>	<i>Stonington</i>	<i>Waterford</i>			

Non SMSA

Minority

Female

Litchfield – Windham				5.9%	6.9%
<i>Abington</i>	<i>Ashford</i>	<i>Ballouville</i>	<i>Bantam</i>		
<i>Barkhamsted</i>	<i>Bethlehem</i>	<i>Bridgewater</i>	<i>Brooklyn</i>		
<i>Canaan</i>	<i>Canterbury</i>	<i>Central Village</i>	<i>Chaplin</i>		
<i>Colebrook</i>	<i>Cornwall</i>	<i>Cornwall Bridge</i>	<i>Danielson</i>		
<i>Dayville</i>	<i>East Canaan</i>	<i>East Killingly</i>	<i>East Woodstock</i>		
<i>Eastford</i>	<i>Falls Village</i>	<i>Gaylordsville</i>	<i>Goshen</i>		
<i>Grosvenor Dale</i>	<i>Hampton</i>	<i>Harwinton</i>	<i>Kent</i>		
<i>Killingly</i>	<i>Lakeside</i>	<i>Litchfield</i>	<i>Moosup</i>		
<i>Morris</i>	<i>New Milford</i>	<i>New Preston</i>	<i>New Preston Marble Dale</i>		
<i>Norfolk</i>	<i>North Canaan</i>	<i>No. Grosvenordale</i>	<i>North Windham</i>		
<i>Oneco</i>	<i>Pequabuck</i>	<i>Pine Meadow</i>	<i>Plainfield</i>		
<i>Pleasant Valley</i>	<i>Pomfret</i>	<i>Pomfret Center</i>	<i>Putnam</i>		
<i>Quinebaug</i>	<i>Riverton</i>	<i>Rogers</i>	<i>Roxbury</i>		
<i>Salisbury</i>	<i>Scotland</i>	<i>Sharon</i>	<i>South Kent</i>		
<i>South Woodstock</i>	<i>Sterling</i>	<i>Taconic</i>	<i>Terryville</i>		
<i>Thompson</i>	<i>Torrington</i>	<i>Warren</i>	<i>Warrenville</i>		
<i>Washington</i>	<i>Washington Depot</i>	<i>Wauregan</i>	<i>West Cornwall</i>		
<i>Willimantic</i>	<i>Winchester</i>	<i>Winchester Center</i>	<i>Windham</i>		
<i>Winsted</i>	<i>Woodstock</i>	<i>Woodstock Valley</i>			

Contractor's Exempt Purchase Certificate

General Purpose: Contractors for the repair, alteration, improvement, remodeling, or construction of real property use this certificate to purchase materials and supplies to be installed or placed in a project being performed under contract with an exempt entity. The materials and supplies must remain in the project after its completion, including tangible personal property that remains tangible personal property after its installation or placement. If the tangible personal property is not used in the manner described above, a contractor who claimed an exemption owes use tax on the total price of the tangible personal property.

Wherever the term contractor is used in this certificate, it includes subcontractors of the contractor performing a contract with an exempt entity.

Exempt entity means any person entitled to make purchases of tangible personal property exempt from sales and use taxes under the statutory authority listed below.

Statutory and Regulatory Authority: Conn. Gen. Stat. §12-412(1), (2), (5), (8), (84), (90), (92), (93), and (95); Conn. Gen. Stat. §§7-273mm, 16-344, and 32-23h; and Conn. Agencies Regs. §12-426-18.

Instructions for the Purchaser: Use this certificate for purchases of tangible personal property to be installed or placed in a project being performed under a contract with an exempt entity that will remain in the project after its completion. To qualify for the exemption from sales and use taxes, you must present this certificate to the retailer at the time of the purchase of the qualifying tangible personal property. For at least six years from the date it is issued, keep a copy of this certificate and records that substantiate the information entered on this certificate, including records to support the contractor's use of this certificate and to show the disposition of all materials or supplies so purchased.

If you are unable to designate the exact amount of materials or supplies to be installed or placed in a project being performed under contract with an exempt entity, you must estimate the amount of the purchases. You will be held strictly accountable for any use tax due the state on the purchases in the event of any use other than the permanent installation or placement of the purchases in the exempt project identified in this certificate.

Contractors are the consumers of all the tools, supplies, and equipment used in fulfilling a construction contract that are not installed or placed in the exempt job even if they are used up during the job.

Instructions for the Seller: Acceptance of this certificate, when properly completed, relieves the seller from the burden of proving that tangible personal property is not subject to sales and use taxes when the tangible personal property will be installed or placed in a project being performed under a contract with an exempt entity and will remain in the project after its completion. The certificate is valid only if taken in good faith from a contractor under contract with an exempt entity. The good faith of the seller will be questioned if the seller knows of, or should know of, facts that suggest the contractor does not intend to install or place the property in a project being performed under contract with an exempt entity.

Keep this certificate and bills or invoices to the purchaser for at least six years from the date of purchase. The bills, invoices, or records covering the purchase made under this certificate must be marked to indicate an exempt purchase was made. The words "Exempt under CERT-141" satisfy the requirement.

This certificate may be used for individual purchases, in which case the box marked "Certificate for One Purchase Only" must be checked. This certificate may also be used for a continuing line of exempt purchases for the project identified in this certificate, in which case the box marked "Blanket Certificate" must be checked. A blanket certificate remains in effect for three years unless the purchaser revokes it in writing before the period expires.

For More Information: Call Taxpayer Services at 1-800-382-9463 (Connecticut calls outside the Greater Hartford calling area only) or 860-297-5962 (from anywhere). **TTY, TDD, and Text Telephone users** only may transmit inquiries anytime by calling 860-297-4911. Visit the Department of Revenue Services (DRS) website at www.ct.gov/DRS to preview and download forms and publications.

Name of Exempt Entity	Address	CT Tax Registration Number (If none, explain.)	Federal Employer ID #
			CT Exemption Permit Number (If any)
Address of Project			
Type of Exempt Entity (Check one.)			
<input type="checkbox"/> State Government <input type="checkbox"/> Federal Government <input type="checkbox"/> Town <input type="checkbox"/> School <input type="checkbox"/> Fire Department <input type="checkbox"/> Police Department <input type="checkbox"/> Library <input type="checkbox"/> Other (Explain) _____			
Name of Purchaser	Address	CT Tax Registration Number (If none, explain.)	Federal Employer ID #
Name of Seller	Address	CT Tax Registration Number (If none, explain.)	Federal Employer ID #
Provide a written description of each item purchased.			
Check one box: <input type="checkbox"/> Blanket Certificate <input type="checkbox"/> Certificate for One Purchase Only			

Declaration by Purchaser

The item(s) described above are tangible personal property to be installed or placed in a project being performed under contract with the exempt entity identified above and will remain in the project after its completion. I declare that the purchaser named above is a contractor under contract with the exempt entity or a subcontractor of the contractor. I acknowledge that the purchaser will be liable for Connecticut use tax, plus applicable penalty and interest as of the date of purchase, on the total purchase price of the property if any of the requirements for the exemption are not present or are not met.

Declaration: I declare under penalty of law that I have examined this document (including any accompanying schedules and statements) and, to the best of my knowledge and belief, it is true, complete, and correct. I understand the penalty for willfully delivering a false return or document to DRS is a fine of not more than \$5,000 or imprisonment for not more than five years, or both.

Name of Purchaser

By: _____
Authorized Signature Title Date

Health Insurance Portability and Accountability Act of 1996 (“HIPAA”).

- (a) If the Contactor is a Business Associate under the requirements of the Health Insurance Portability and Accountability Act of 1996 (“HIPAA”), the Contractor must comply with all terms and conditions of this Section of the Contract. If the Contractor is not a Business Associate under HIPAA, this Section of the Contract does not apply to the Contractor for this Contract.
- (b) The Contractor is required to safeguard the use, publication and disclosure of information on all applicants for, and all clients who receive, services under the Contract in accordance with all applicable federal and state law regarding confidentiality, which includes but is not limited to HIPAA, more specifically with the Privacy and Security Rules at 45 C.F.R. Part 160 and Part 164, subparts A, C, and E; and
- (c) The State of Connecticut Agency named on page 1 of this Contract (hereinafter the “Department”) is a “covered entity” as that term is defined in 45 C.F.R. § 160.103; and
- (d) The Contractor, on behalf of the Department, performs functions that involve the use or disclosure of “individually identifiable health information,” as that term is defined in 45 C.F.R. § 160.103; and
- (e) The Contractor is a “business associate” of the Department, as that term is defined in 45 C.F.R. § 160.103; and
- (f) The Contractor and the Department agree to the following in order to secure compliance with the HIPAA, the requirements of Subtitle D of the Health Information Technology for Economic and Clinical Health Act (hereinafter the HITECH Act), (Pub. L. 111-5, sections 13400 to 13423), and more specifically with the Privacy and Security Rules at 45 C.F.R. Part 160 and Part 164, subparts A, C, and E.
- (g) Definitions
 - (1) “Breach shall have the same meaning as the term is defined in section 13400 of the HITECH Act (42 U.S.C. §17921(1))
 - (2) “Business Associate” shall mean the Contractor.
 - (3) “Covered Entity” shall mean the Department of the State of Connecticut named on page 1 of this Contract.
 - (4) “Designated Record Set” shall have the same meaning as the term “designated record set” in 45 C.F.R. § 164.501.

- (5) "Electronic Health Record" shall have the same meaning as the term is defined in section 13400 of the HITECH Act (42 U.S.C. §17921(5))
 - (6) "Individual" shall have the same meaning as the term "individual" in 45 C.F.R. § 160.103 and shall include a person who qualifies as a personal representative as defined in 45 C.F.R. § 164.502(g).
 - (7) "Privacy Rule" shall mean the Standards for Privacy of Individually Identifiable Health Information at 45 C.F.R. part 160 and parts 164, subparts A and E.
 - (8) "Protected Health Information" or "PHI" shall have the same meaning as the term "protected health information" in 45 C.F.R. § 160.103, limited to information created or received by the Business Associate from or on behalf of the Covered Entity.
 - (9) "Required by Law" shall have the same meaning as the term "required by law" in 45 C.F.R. § 164.103.
 - (10) "Secretary" shall mean the Secretary of the Department of Health and Human Services or his designee.
 - (11) "More stringent" shall have the same meaning as the term "more stringent" in 45 C.F.R. § 160.202.
 - (12) "This Section of the Contract" refers to the HIPAA Provisions stated herein, in their entirety.
 - (13) "Security Incident" shall have the same meaning as the term "security incident" in 45 C.F.R. § 164.304.
 - (14) "Security Rule" shall mean the Security Standards for the Protection of Electronic Protected Health Information at 45 C.F.R. part 160 and parts 164, subpart A and C.
 - (15) "Unsecured protected health information" shall have the same meaning as the term as defined in section 13402(h)(1)(A) of HITECH. Act. (42 U.S.C. §17932(h)(1)(A)).
- (h) Obligations and Activities of Business Associates.
- (1) Business Associate agrees not to use or disclose PHI other than as permitted or required by this Section of the Contract or as Required by Law.

- (2) Business Associate agrees to use appropriate safeguards to prevent use or disclosure of PHI other than as provided for in this Section of the Contract.
- (3) Business Associate agrees to use administrative, physical and technical safeguards that reasonably and appropriately protect the confidentiality, integrity, and availability of electronic protected health information that it creates, receives, maintains, or transmits on behalf of the Covered Entity.
- (4) Business Associate agrees to mitigate, to the extent practicable, any harmful effect that is known to the Business Associate of a use or disclosure of PHI by Business Associate in violation of this Section of the Contract.
- (5) Business Associate agrees to report to Covered Entity any use or disclosure of PHI not provided for by this Section of the Contract or any security incident of which it becomes aware.
- (6) Business Associate agrees to insure that any agent, including a subcontractor, to whom it provides PHI received from, or created or received by Business Associate, on behalf of the Covered Entity, agrees to the same restrictions and conditions that apply through this Section of the Contract to Business Associate with respect to such information.
- (7) Business Associate agrees to provide access, at the request of the Covered Entity, and in the time and manner agreed to by the parties, to PHI in a Designated Record Set, to Covered Entity or, as directed by Covered Entity, to an Individual in order to meet the requirements under 45 C.F.R. § 164.524.
- (8) Business Associate agrees to make any amendments to PHI in a Designated Record Set that the Covered Entity directs or agrees to pursuant to 45 C.F.R. § 164.526 at the request of the Covered Entity, and in the time and manner agreed to by the parties.
- (9) Business Associate agrees to make internal practices, books, and records, including policies and procedures and PHI, relating to the use and disclosure of PHI received from, or created or received by, Business Associate on behalf of Covered Entity, available to Covered Entity or to the Secretary in a time and manner agreed to by the parties or designated by the Secretary, for purposes of the Secretary determining Covered Entity's compliance with the Privacy Rule.
- (10) Business Associate agrees to document such disclosures of PHI and information related to such disclosures as would be required for Covered Entity to respond to a request by an Individual for an accounting of disclosures of PHI in accordance with 45 C.F.R. § 164.528 and section

13405 of the HITECH Act (42 U.S.C. § 17935) and any regulations promulgated thereunder.

- (11) Business Associate agrees to provide to Covered Entity, in a time and manner agreed to by the parties, information collected in accordance with clause h. (10) of this Section of the Contract, to permit Covered Entity to respond to a request by an Individual for an accounting of disclosures of PHI in accordance with 45 C.F.R. § 164.528 and section 13405 of the HITECH Act (42 U.S.C. § 17935) and any regulations promulgated thereunder. Business Associate agrees at the Covered Entity's direction to provide an accounting of disclosures of PHI directly to an individual in accordance with 45 C.F.R. § 164.528 and section 13405 of the HITECH Act (42 U.S.C. § 17935) and any regulations promulgated thereunder.
- (12) Business Associate agrees to comply with any state or federal law that is more stringent than the Privacy Rule.
- (13) Business Associate agrees to comply with the requirements of the HITECH Act relating to privacy and security that are applicable to the Covered Entity and with the requirements of 45 C.F.R. sections 164.504(e), 164.308, 164.310, 164.312, and 164.316.
- (14) In the event that an individual requests that the Business Associate (a) restrict disclosures of PHI; (b) provide an accounting of disclosures of the individual's PHI; or (c) provide a copy of the individual's PHI in an electronic health record, the Business Associate agrees to notify the covered entity, in writing, within two business days of the request.
- (15) Business Associate agrees that it shall not, directly or indirectly, receive any remuneration in exchange for PHI of an individual without (1) the written approval of the covered entity, unless receipt of remuneration in exchange for PHI is expressly authorized by this Contract and (2) the valid authorization of the individual, except for the purposes provided under section 13405(d)(2) of the HITECH Act, (42 U.S.C. § 17935(d)(2)) and in any accompanying regulations
- (16) Obligations in the Event of a Breach
 - A. The Business Associate agrees that, following the discovery of a breach of unsecured protected health information, it shall notify the Covered Entity of such breach in accordance with the requirements of section 13402 of HITECH (42 U.S.C. 17932(b) and the provisions of this Section of the Contract.
 - B. Such notification shall be provided by the Business Associate to the Covered Entity without unreasonable delay, and in no case later than 30 days after the breach is discovered by the Business Associate, except as otherwise instructed in writing by a law enforcement official

- C. The Business Associate agrees to include in the notification to the Covered Entity at least the following information:
1. A brief description of what happened, including the date of the breach and the date of the discovery of the breach, if known.
 2. A description of the types of unsecured protected health information that were involved in the breach (such as full name, Social Security number, date of birth, home address, account number, or disability code).
 3. The steps the Business Associate recommends that individuals take to protect themselves from potential harm resulting from the breach.
 4. A detailed description of what the Business Associate is doing to investigate the breach, to mitigate losses, and to protect against any further breaches.
 5. Whether a law enforcement official has advised either verbally or in writing the Business Associate that he or she has determined that notification or notice to individuals or the posting required under section 13402 of the HITECH Act would impede a criminal investigation or cause damage to national security and; if so, include contact information for said official.
- D. Business Associate agrees to provide appropriate staffing and have established procedures to ensure that individuals informed by the Covered Entity of a breach by the Business Associate have the opportunity to ask questions and contact the Business Associate for additional information regarding the breach. Such procedures shall include a toll-free telephone number, an e-mail address, a posting on its Web site and a postal address. Business Associate agrees to include in the notification of a breach by the Business Associate to the

E. Business Associate agrees that, in the event of a breach, it has the burden to demonstrate that it has complied with all notifications requirements set forth above, including evidence demonstrating the necessity of a delay in notification to the Covered Entity.

(i) Permitted Uses and Disclosure by Business Associate.

(1) General Use and Disclosure Provisions Except as otherwise limited in this Section of the Contract, Business Associate may use or disclose PHI to perform functions, activities, or services for, or on behalf of, Covered Entity as specified in this Contract, provided that such use or disclosure would not violate the Privacy Rule if done by Covered Entity or the minimum necessary policies and procedures of the Covered Entity.

(2) Specific Use and Disclosure Provisions

(A) Except as otherwise limited in this Section of the Contract, Business Associate may use PHI for the proper management and administration of Business Associate or to carry out the legal responsibilities of Business Associate.

(B) Except as otherwise limited in this Section of the Contract, Business Associate may disclose PHI for the proper management and administration of Business Associate, provided that disclosures are Required by Law, or Business Associate obtains reasonable assurances from the person to whom the information is disclosed that it will remain confidential and used or further disclosed only as Required by Law or for the purpose for which it was disclosed to the person, and the person notifies Business Associate of any instances of which it is aware in which the confidentiality of the information has been breached.

(C) Except as otherwise limited in this Section of the Contract, Business Associate may use PHI to provide Data Aggregation services to Covered Entity as permitted by 45 C.F.R. § 164.504(e)(2)(i)(B).

(j) Obligations of Covered Entity.

(1) Covered Entity shall notify Business Associate of any limitations in its notice of privacy practices of Covered Entity, in accordance with 45 C.F.R. § 164.520, or to the extent that such limitation may affect Business Associate's use or disclosure of PHI.

- (2) Covered Entity shall notify Business Associate of any changes in, or revocation of, permission by Individual to use or disclose PHI, to the extent that such changes may affect Business Associate's use or disclosure of PHI.
 - (3) Covered Entity shall notify Business Associate of any restriction to the use or disclosure of PHI that Covered Entity has agreed to in accordance with 45 C.F.R. § 164.522, to the extent that such restriction may affect Business Associate's use or disclosure of PHI.
- (k) Permissible Requests by Covered Entity. Covered Entity shall not request Business Associate to use or disclose PHI in any manner that would not be permissible under the Privacy Rule if done by the Covered Entity, except that Business Associate may use and disclose PHI for data aggregation, and management and administrative activities of Business Associate, as permitted under this Section of the Contract.
- (l) Term and Termination.
- (1) Term. The Term of this Section of the Contract shall be effective as of the date the Contract is effective and shall terminate when the information collected in accordance with clause h. (10) of this Section of the Contract is provided to the Covered Entity and all of the PHI provided by Covered Entity to Business Associate, or created or received by Business Associate on behalf of Covered Entity, is destroyed or returned to Covered Entity, or, if it is infeasible to return or destroy PHI, protections are extended to such information, in accordance with the termination provisions in this Section.
 - (2) Termination for Cause Upon Covered Entity's knowledge of a material breach by Business Associate, Covered Entity shall either:
 - (A) Provide an opportunity for Business Associate to cure the breach or end the violation and terminate the Contract if Business Associate does not cure the breach or end the violation within the time specified by the Covered Entity; or
 - (B) Immediately terminate the Contract if Business Associate has breached a material term of this Section of the Contract and cure is not possible; or
 - (C) If neither termination nor cure is feasible, Covered Entity shall report the violation to the Secretary.
 - (3) Effect of Termination

(A) Except as provided in (l)(2) of this Section of the Contract, upon termination of this Contract, for any reason, Business Associate shall return or destroy all PHI received from Covered Entity, or created or received by Business Associate on behalf of Covered Entity. Business Associate shall also provide the information collected in accordance with clause h. (10) of this Section of the Contract to the Covered Entity within ten business days of the notice of termination. This provision shall apply to PHI that is in the possession of subcontractors or agents of Business Associate. Business Associate shall retain no copies of the PHI.

(B) In the event that Business Associate determines that returning or destroying the PHI is infeasible, Business Associate shall provide to Covered Entity notification of the conditions that make return or destruction infeasible. Upon documentation by Business Associate that return or destruction of PHI is infeasible, Business Associate shall extend the protections of this Section of the Contract to such PHI and limit further uses and disclosures of PHI to those purposes that make return or destruction infeasible, for as long as Business Associate maintains such PHI. Infeasibility of the return or destruction of PHI includes, but is not limited to, requirements under state or federal law that the Business Associate maintains or preserves the PHI or copies thereof.

(m) Miscellaneous Provisions.

(1) Regulatory References. A reference in this Section of the Contract to a section in the Privacy Rule means the section as in effect or as amended.

(2) Amendment. The Parties agree to take such action as is necessary to amend this Section of the Contract from time to time as is necessary for Covered Entity to comply with requirements of the Privacy Rule and the Health Insurance Portability and Accountability Act of 1996, Pub. L. No. 104-191.

(3) Survival. The respective rights and obligations of Business Associate shall survive the termination of this Contract.

(4) Effect on Contract. Except as specifically required to implement the purposes of this Section of the Contract, all other terms of the Contract shall remain in force and effect.

(5) Construction. This Section of the Contract shall be construed as broadly as necessary to implement and comply with the Privacy Standard. Any ambiguity in this Section of the Contract shall be resolved in favor of a meaning that complies, and is consistent with, the Privacy Standard.

(6) Disclaimer. Covered Entity makes no warranty or representation that compliance with this Section of the Contract will be adequate or satisfactory for Business Associate's own purposes. Covered Entity shall not be liable to Business Associate for any claim, civil or criminal penalty, loss or damage related to or arising from the unauthorized use or disclosure of PHI by Business Associate or any of its officers, directors, employees, contractors or agents, or any third party to whom Business Associate has disclosed PHI contrary to the provisions of this Contract or applicable law. Business Associate is solely responsible for all decisions made, and actions taken, by Business Associate regarding the safeguarding, use and disclosure of PHI within its possession, custody or control.

(7) Indemnification. The Business Associate shall indemnify and hold the Covered Entity harmless from and against any and all claims, liabilities, judgments, fines, assessments, penalties, awards and any statutory damages that may be imposed or assessed pursuant to HIPAA, as amended or the HITECH Act, including, without limitation, attorney's fees, expert witness fees, costs of investigation, litigation or dispute resolution, and costs awarded thereunder, relating to or arising out of any violation by the Business Associate and its agents, including subcontractors, of any obligation of Business Associate and its agents, including subcontractors, under this section of the contract, under HIPAA, the HITECH Act, the Privacy Rule and the Security Rule.

STATE OF CONNECTICUT

BY HIS EXCELLENCY

THOMAS J. MESKILL

GOVERNOR

EXECUTIVE ORDER NO. THREE

WHEREAS, sections 4-61d(b) and 4-114a of the 1969 supplement to the general statutes require nondiscrimination clauses in state contracts and subcontracts for construction on public buildings, other public works and goods and services, and

WHEREAS, section 4-61e(c) of the 1969 supplement to the general statutes requires the labor department to encourage and enforce compliance with this policy by both employers and labor unions, and to promote equal employment opportunities, and

WHEREAS, the government of this state recognizes the duty and desirability of its leadership in providing equal employment opportunity, by implementing these laws,

NOW, THEREFORE, I, THOMAS J. MESKILL, Governor of the State of Connecticut, acting by virtue of the authority vested in me under section twelve of article fourth of the constitution of the state, as supplemented by section 3-1 of the general statutes, do hereby ORDER and DIRECT, as follows, by this Executive Order:

I

The labor commissioner shall be responsible for the administration of this Order and shall adopt such regulations as he deems necessary and appropriate to achieve the purposes of this Order. Upon the promulgation of this Order, the commissioner of finance and control shall issue a directive forthwith to all state agencies, that henceforth all state contracts and subcontracts for construction on public buildings, other public works and goods and services shall contain a provision rendering such contract or subcontract subject to this Order, and that such contract or subcontract may be cancelled, terminated or suspended by the labor commissioner for violation of or noncompliance with this Order or state or federal laws concerning nondiscrimination, notwithstanding that the labor commissioner is not a party to such contract or subcontract.

II

Each contractor having a contract containing the provisions prescribed in section 4-114a of the 1969 supplement to the general statutes, shall file, and shall cause each of his subcontractors to file, compliance reports with the contracting agency or the labor commissioner, as may be directed such reports shall be filed within such times and shall contain such information as to employment policies and statistics of the contractor and each subcontractor, and shall be in such form as the labor commissioner may prescribe. Bidders or prospective contractors or

subcontractors may be required to state whether they have participated in any previous contract subject to the provisions of this Order or any preceding similar Order, and in that event to submit on behalf of themselves and their proposed subcontractors compliance reports prior to or as an initial part of their bid or negotiation of a contract.

III

Whenever the contractor or subcontractor has a collective bargaining agreement or other contract or understanding with a labor organization or employment agency as defined in section 31-122 of the general statutes, the compliance report shall identify the said organization or agency and the contracting agency or the labor commissioner may require a compliance report to be filed with the contracting agency or the labor commissioner, as may be directed, by such organization or agency, signed by an authorized officer or agent of such organization or agency, with supporting information, to the effect that the signer's practices and policies, including but not limited to matters concerning personnel, training, apprenticeship, membership, grievance and representation, and upgrading, do not discriminate on grounds of race, color, religious creed, age, sex or national origin, or ancestry of any individual, and that the signer will either affirmatively cooperate in the implementation of the policy and provisions of this Order, or that it consents and agrees that recruitment, employment and the terms and conditions of employment under the proposed contract shall be in accordance with the purposes and provisions of the Order.

IV

The labor commissioner may by regulation exempt certain classes of contracts, subcontracts or purchase orders from the implementation of this Order, for standard commercial supplies or raw materials, for less than specified amounts of money or numbers of workers or for subcontractors below a specified tier. The labor commissioner may also provide by regulation for the exemption of facilities of a contractor which are in all respects separate and distinct from activities of the contractor related to the performance of the state contract, provided only that such exemption will not interfere with or impede the implementation of this Order, and provided further, that in the absence of such an exemption, all facilities shall be covered by the provisions of this Order.

V

Each contracting agency shall be primarily responsible for obtaining compliance with the regulations of the labor commissioner with respect to contracts entered into by such agency or its contractors. All contracting agencies shall comply with the regulations of the labor commissioner in discharging their primary responsibility for securing compliance with the provisions of contracts and otherwise with the terms of this Order and of the regulations of the labor commissioner issued pursuant to this Order. They are directed to cooperate with the labor commissioner and to furnish the labor commissioner such information and assistance as he may require in the performance of his functions under this Order. They are further directed to appoint or designate from among the personnel of each agency, compliance officers, whose duty shall be to seek compliance with the objectives of this Order by conference, conciliation, mediation, or persuasion.

VI

The labor commissioner may investigate the employment practices and procedures of any state contractor or subcontractor and the practices and policies of any labor organization or employment agency hereinabove described, relating to employment under the state contract, as concerns nondiscrimination by such organization or agency as hereinabove described, or the labor commissioner may initiate such investigation by the appropriate contract agency, to determine whether or not the contractual provisions hereinabove specified or statutes of the state respecting them have been violated. Such investigation shall be conducted in accordance with the procedures established by the labor commissioner and the investigating agency shall report to the labor commissioner any action taken or recommended.

VII

The labor commissioner shall receive and investigate or cause to be investigated complaints by employees or prospective employees of a state contractor or subcontractor or members or applicants for membership or apprenticeship or training in a labor organization or employment agency hereinabove described, which allege discrimination contrary to the contractual provisions specified hereinabove or state statutes requiring nondiscrimination in employment opportunity. If this investigation is conducted for the labor commissioner by a contracting agency, that agency shall report to the labor commissioner what action has been taken or is recommended with regard to such complaints

VIII

The labor commissioner shall use his best efforts, directly and through contracting agencies, other interested federal, state and local agencies, contractors and all other available instrumentalities, including the commission on human rights and opportunities, the executive committee on human rights and opportunities, and the apprenticeship council under its mandate to provide advice and counsel to the labor commissioner in providing equal employment opportunities to all apprentices and to provide training, employment and upgrading opportunities for disadvantaged workers, in accordance with section 31-51(d) of the 1969 supplement to the general statutes, to cause any labor organization or any employment agency whose members are engaged in work under government contracts or referring workers or providing or supervising apprenticeship or training for or in the course of work under a state contract or subcontract to cooperate in the implementation of the purposes of this Order. The labor commissioner shall in appropriate cases notify the commission on human rights and opportunities or other appropriate state or federal agencies whenever it has reason to believe that the practices of any such organization or agency violate equal employment opportunity requirements of state or federal law.

IX

The labor commissioner or any agency officer or employee in the executive branch designated by regulation of the labor commissioner may hold such hearings, public or private, as the labor commissioner may deem advisable for compliance, enforcement or educational purposes under this Order.

X

(a) The labor commissioner may hold or cause to be held hearings, prior to imposing ordering or recommending the imposition of penalties and sanctions under this Order. No order for disbarment of any contractor from further state contracts shall be made without affording the contractor an opportunity for a hearing. In accordance with such regulations as the labor commissioner may adopt, the commissioner or the appropriate contracting agency may

(1) Publish or cause to be published the names of contractors or labor organizations or employment agencies as hereinabove described which it has concluded have complied or failed to comply with the provisions of this Order or the regulations of the labor commissioner in implementing this Order.

(2) Recommend to the commission on human rights and opportunities that in cases in which there is substantial or material violation or threat thereof of the contractual provision or related state statutes concerned herein, appropriate proceedings be brought to enforce them, including proceedings by the commission on its own motion under chapter 563 of the general statutes and the enjoining, within the limitations of applicable law, of organizations, individuals or groups who prevent directly or indirectly or seek to prevent directly or indirectly compliance with the provisions of this Order.

(3) Recommend that criminal proceedings be brought under chapter 939 of the general statutes.

(4) Cancel, terminate, suspend or cause to be cancelled, terminated, or suspended in accordance with law any contract or any portion or portions thereof for failure of the contractor or subcontractor to comply with the nondiscrimination provisions of the contract. Contracts may be cancelled, terminated, suspended absolutely or their continuance conditioned upon a program for fixture compliance approved by the contracting agency.

(5) Provide that any contracting agency shall refrain from entering into any further contracts or extensions or modifications of existing contracts with any contractor until he has satisfied the labor commissioner that he has established and will carry out personnel and employment policies compliant with this Order.

(6) Under regulations prescribed by the labor commissioner each contracting agency shall make reasonable efforts within a reasonable period of time to secure compliance with the contract provisions of this Order by methods of conference conciliation, mediation or persuasion, before other proceedings shall be instituted under this Order or before a state contract shall be cancelled or terminated in whole or in part for failure of the contractor or subcontractor to comply with the contract provisions of state statute and this Order.

(b) Any contracting agency taking any action authorized by this Order, whether on its own motion or as directed by the labor commissioner or pursuant to his regulations shall promptly

notify *him* of such action. Whenever the labor commissioner makes a determination under this Order, he shall promptly notify the appropriate contracting agency and other interested federal, state and local agencies of the action recommended. The state and local agency or agencies shall take such action and shall report the results thereof to the labor commissioner within such time as he shall specify.

XI

If the labor commissioner shall so direct, contracting agencies shall not enter into contracts with any bidder or prospective contractor unless he has satisfactorily complied with the provisions of this Order, or submits a program, for compliance acceptable to the labor commissioner, or if the labor commissioner so authorizes, to the contracting agency.

XII

Whenever a contracting agency cancels or terminates a contract, or a contractor has been disbarred from, further government contracts because of noncompliance with the contract provisions with regard to nondiscrimination, the labor commissioner or the contracting agency shall rescind such disbarment, upon the satisfaction of the labor commissioner that the contractor has purged himself of such noncompliance and will thenceforth carry out personnel and employment policies of nondiscrimination in compliance with the provision of this order.

XIII

The labor commissioner may delegate to any officer, agency or employee in the executive branch any function or duty of the labor commissioner under this Order except authority to promulgate regulations of a general nature.

XIV

This Executive Order supplements the Executive Order issued on September 28, 1967. All regulations, orders, instructions, designations and other directives issued heretofore in these premises, including those issued by the heads of various departments or agencies under or pursuant to prior order or statute, shall remain in full force and effect, unless and until revoked or superceded by appropriate authority, to the extent that they are not inconsistent with this Order.

This Order shall become effective thirty days after the date of this Order.

Dated at Hartford, Connecticut, this 16th day of June, 1971.

Thomas J. Meskill, GOVERNOR

Filed this ____ day of June, 1971.

**STATE OF CONNECTICUT
BY HER EXCELLENCY
M. JODI RELL
GOVERNOR**

EXECUTIVE ORDER NO. 14

WHEREAS, cleaning and sanitizing products are necessary for creating and maintaining clean, healthy and sanitary conditions in State facilities and workplaces;

WHEREAS, exposure to harmful chemicals contained in cleaning and sanitizing products may result in potential impacts to human health;

WHEREAS, harmful chemicals, byproducts and waste contained in certain cleaning and sanitizing products may be released into the environment during the routine cleaning and sanitization of State facilities normal use;

WHEREAS, choosing less harmful cleaning and sanitizing products for use in State facilities and workplaces and taking steps to reduce exposure by office and custodial workers, will minimize potential impacts on human health, will improve environmental quality and will reduce pollution;

WHEREAS, the procurement and the proper use and application of cleaning and sanitizing products that perform well and that have positive environmental attributes such as biodegradability, low toxicity, low volatile organic compound content, reduced packaging, and low life cycle energy use will reduce the environmental impacts of routine cleaning and sanitizing activities while also ensuring clean and sanitary State facilities; and

NOW, THEREFORE, I, M. Jodi Rell, Governor of the State of Connecticut, by virtue of the authority vested in me by the Constitution and Statutes of the State, do hereby ORDER and DIRECT:

All state agencies in the executive branch shall procure and use, whenever practicable, cleaning and/or sanitizing products having properties that minimize potential impacts to human health and the environment, consistent with maintaining clean and sanitary State facilities.

All state agencies in the executive branch and all higher education agencies and institutions, shall, when procuring or contracting for cleaning and/or sanitizing services provide in such contracts or procurement agreements, require contractors of the State or persons or entities providing cleaning and/or sanitizing services to the State use cleaning and/or sanitizing products having properties that minimize potential impacts to human health and the environment, consistent with maintaining clean and sanitary facilities.

All state agencies in the executive branch shall include in new contracts for the procurement of cleaning products or cleaning services, an appropriate requirement consistent with this Executive Order and the standards and guidelines established by the Department of Administrative Services under Paragraph 3 of this Executive Order.

The Department of Administrative Services, in consultation with the Department of Public Health, the Department of Public Works and the Department of Environmental Protection, shall not later than January 1, 2007, establish and publish written standards and guidelines to provide direction to all state agencies in the executive branch in connection with the implementation of this Executive Order.

The Department of Administrative Services shall provide the Office of the Governor with a report assessing the effectiveness of this Executive Order within one year of the effective date of this Executive Order.

Municipal governments, political subdivisions and school districts that are not expressly subject to the requirements of this Order are encouraged to review their purchasing and use of cleaning products and/or sanitizing products and are hereby urged to comply with the provisions of this Executive Order where deemed appropriate.

Municipal governments, political subdivisions and school districts that are not expressly subject to the requirements of this Executive Order are hereby requested and encouraged to review their procurement and use of cleaning and/or sanitizing products and are urged to comply with the provisions of this Executive Order. Such entities may to the extent they deem appropriate, in order to minimize potential impacts to human health and the environment, and consistent with maintaining clean and sanitary facilities seek guidance and assistance consistent with the provisions of Paragraph 3 of this Executive Order from the Departments of Administrative Services, Public Works, Public Health and Environmental Protection.

All state agencies in the executive branch covered by this Executive Order shall, wherever feasible, in a manner that is financially feasible, commercially reasonable and practicable, immediately transition to environmentally and health-friendly cleaning and/or sanitizing products. Such transition shall be accomplished as soon as possible and in a manner that avoids the waste of existing inventories, accommodates establishment of supply chains for new products, enables the training of personnel in appropriate work practices, and allows the phase-out of products and practices inconsistent with this Executive Order.

This Order shall take effect immediately.

Dated at Hartford this 17th day of April, 2006

M. JODI RELL

Governor

By Her Excellency's Command:

Susan Bysiewicz

Secretary of the State

The Executive Office of Governor John G. Rowland
State of Connecticut

By His Excellency

John G. Rowland

Governor

Executive Order No. Sixteen

WHEREAS, the State of Connecticut recognizes that workplace violence is a growing problem that must be addressed; and

WHEREAS, the State is committed to providing its employees a reasonably safe and healthy working environment, free from intimidation, harassment, threats, and /or violent acts; and

WHEREAS, violence or the threat of violence by or against any employee of the State of Connecticut or member of the public in the workplace is unacceptable and will subject the perpetrator to serious disciplinary action up to and including discharge and criminal penalties.

NOW, THEREFORE, I, John G. Rowland, Governor of the State of Connecticut, acting by virtue of the authority vested in me by the Constitution and by the statutes of this state, do hereby ORDER and DIRECT:

1. That all state agency personnel, contractors, subcontractors, and vendors comply with the following **Violence in the Workplace Prevention Policy**:

The State of Connecticut adopts a statewide zero tolerance policy for workplace violence.

Therefore, except as may be required as a condition of employment^{3/4}

- o No employee shall bring into any state worksite any weapon or dangerous instrument as defined herein.
- o No employee shall use, attempt to use, or threaten to use any such weapon or dangerous instrument in a state worksite.
- o No employee shall cause or threaten to cause death or physical injury to any individual in a state worksite.

Weapon means any firearm, including a BB gun, whether loaded or unloaded, any knife (excluding a small pen or pocket knife), including a switchblade or other knife having an automatic spring release device, a stiletto, any police baton or nightstick or any martial arts weapon or electronic defense weapon.

Dangerous instrument means any instrument, article, or substance that, under the circumstances, is capable of causing death or serious physical injury.

Violation of the above reasonable work rules shall subject the employee to disciplinary action up to and including discharge.

2. That each agency must prominently post this policy and that all managers and supervisors must clearly communicate this policy to all state employees
3. That all managers and supervisors are expected to enforce this policy fairly and uniformly.

4. That any employee who feels subjected to or witnesses violent, threatening, harassing, or intimidating behavior in the workplace immediately report the incident or statement to their supervisor, manager, or human resources office.
5. That any employee who believes that there is a serious threat to their safety or the safety of others that requires immediate attention notify proper law enforcement authorities and his or her manager or supervisor
6. That any manager or supervisor receiving such a report shall immediately contact their human resources office to evaluate, investigate and take appropriate action.
7. That all parties must cooperate fully when questioned regarding violations of this policy.
8. That all parties be advised that any weapon or dangerous instrument at the worksite will be confiscated and that there is no reasonable expectation of privacy with respect to such items in the workplace.
9. That this order applies to all state employees in the executive branch.
10. That each agency will monitor the effective implementation of this policy.
11. That this order shall take effect immediately.

Dated in Hartford, Connecticut, this fourth day of August, 1999.

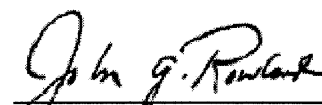
JOHN G. ROWLAND, Governor

Filed this 4th day of August, 1999.

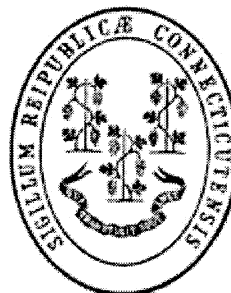

SUSAN BYSIEWICZ, Secretary of the State

Content Last Modified on 4/12/2004 2:34:16 PM

State Of Connecticut

By His Excellency

Thomas J. Meskill

Governor

Executive Order No. Seventeen

WHEREAS, Section 31-237 of the General Statutes of Connecticut as amended requires the maintaining of the established free services of the Connecticut State Employment Service to both employers and prospective employees and

WHEREAS, Section 31-5 of the General Statutes of Connecticut requires that no compensation or fee shall be charged or received directly or indirectly for the services of the Connecticut State Employment Service and

WHEREAS, large numbers of our citizens who have served in the Armed Forces of our nation are returning to civilian life in our state and seeking employment in civilian occupations and

WHEREAS, we owe a duty as well as gratitude to these returning veterans including the duty to find suitable employment for them and

WHEREAS, many of our handicapped citizens are fully capable of employment and are entitled to be placed in suitable employment and

WHEREAS, many of the citizens of our state who are unemployed are unaware of the job openings and employment opportunities which do in fact exist in our state and

WHEREAS, notwithstanding the free services of the Connecticut State Employment Service, many of our Connecticut employers do not use its free services or do not avail themselves fully of all the services offered,

NOW, THEREFORE, I, THOMAS J. MESKILL, Governor of the State of Connecticut, acting by virtue of the authority vested in me under the fourth article of the Constitution of the State and in accordance with Section 3-1 of the General Statutes, do hereby ORDER and direct, as follows, by this Executive Order:

- I. The Labor Commissioner shall be responsible for the administration of this Order and shall do all acts necessary and appropriate to achieve its purpose. Upon promulgation of this Order, the Commissioner of Finance and Control shall issue a directive forthwith to all state agencies, that henceforth all state contracts and subcontracts for construction on public buildings, other public works and goods and services shall contain a provision rendering such contract or subcontract subject to this Order, and that such contract or subcontract may be cancelled, terminated or suspended by the Labor Commissioner for violation of or noncompliance with this Order, notwithstanding that the Labor Commissioner is not a party to such contract or subcontract.
- II. Every contractor and subcontractor having a contract with the state or any of its agencies, boards, commissions, or departments, every individual partnership, corporation, or business entity having business with the state or who or which seeks to do business with the state, and every bidder or

- prospective bidder who submits a bid or replies to an invitation to bid on any state contract shall list all employment openings with the office of the Connecticut State Employment Service in the area where the work is to be performed or where the services are to be rendered.
- III. All state contracts shall contain a clause which shall be a condition of the contract that the contractor and any subcontractor holding a contract directly under the contractor shall list all employment openings with the Connecticut State Employment Service. The Labor Commissioner may allow exceptions to listings of employment openings which the contractor proposes to fill from within its organization from employees on the rolls of the contractor on the date of publication of the invitation to bid or the date on which the public announcement was published or promulgated advising of the program concerned.
 - IV. Each contracting agency of the state shall be primarily responsible for obtaining compliance with this Executive Order. Each contracting agency shall appoint or designate from among its personnel one or more persons who shall be responsible for compliance with the objectives of this Order.
 - V. The Labor Commissioner shall be and is hereby empowered to inspect the books, records, payroll and personnel data of each individual or business entity subject to this Executive Order and may hold hearings or conferences, formal or informal, in pursuance of the duties and responsibilities hereunto delegated to the Labor Commissioner.
 - VI. The Labor Commissioner or any agency officer or employee in the executive branch designated by regulation of the Labor Commissioner may hold such hearings, public or private, as the Labor Commissioner may deem advisable for compliance, enforcement or educational purposes under this Order.
 - VII. (a) The Labor Commissioner may hold or cause to be held hearings, prior to imposing, ordering, or recommending the imposition of penalties and sanctions under this Order. In accordance herewith, the Commissioner or the appropriate contracting agency may suspend, cancel, terminate, or cause to be suspended, cancelled, or terminated in accordance with law any contract or portion or portions thereof for failure of the contractor or subcontractor to comply with the listing provisions of the contract. Contracts may be cancelled, terminated, suspended absolutely or their continuance conditioned upon a program for future compliance approved by the contracting agency.
(b) Any contracting agency taking any action authorized by this Order, whether on its own motion or as directed by the Labor Commissioner, shall promptly notify him of such action. Whenever the Labor Commissioner makes a determination under this Order, he shall promptly notify the appropriate contracting agency of the action recommended. The agency shall report the results to the Labor Commissioner promptly.
 - VIII. If the Labor Commissioner shall so direct, contracting agencies shall not enter into contracts with any bidder or prospective contractor unless he has satisfactorily complied with the provisions of this Order.

This Order shall become effective sixty days after the date of this Order.

Dated at Hartford, Connecticut, this 15th day of February 1973.

Thomas J. Meskill
Governor

Filed this 15th day of February 1973.

Harry Hammer
Secretary Of The State (Deputy)

The Office of Governor M. Jodi Rell

STATE OF CONNECTICUT

BY HER EXCELLENCY

M. JODI RELL

GOVERNOR

EXECUTIVE ORDER NO. 17

WHEREAS, in September of 2006, I unveiled a comprehensive plan for Connecticut's energy future called "Connecticut's Energy Vision, For a Cleaner, Greener State" ("CT's Energy Vision").

WHEREAS, the CT's Energy Vision put forward a comprehensive plan designed to: reduce the State's reliance on fossil fuels; chart the path for an energy future that focuses on alternative, clean and environmentally friendly energy sources; create incentives for efficient energy choices, make conservation a critical component of state energy policy; strengthen state planning for energy needs and create real savings for consumers.

WHEREAS, The Connecticut Climate Change Action Plan 2005 includes a recommended action for the State procurement of environmentally preferable services and products by increasing preferences for products and services that decrease Green House Gas (GHG) emissions and/or mitigate climate change impact; and

WHEREAS, Public Act 04-252 established a goal for the state to reduce GHG emissions to contribute to the regional GHG reduction goals of 1990 levels by 2010 and 10% below 1990 levels by 2020; and

WHEREAS, Reducing demand for electricity and other energy sources will reduce green house gas emissions associated with global warming; and

WHEREAS, Energy efficiency is recognized as the most cost effective means for reducing the demand for electricity, controlling electric system growth and long term costs, and yielding real cost benefits for the consumer; and

WHEREAS, Utilizing energy efficient appliances and equipment will help mitigate Federally Mandated Congestion Charges (FMCCs) that Connecticut rate payers are subject to; and

WHEREAS, State agencies purchased 670 million kilowatt hours of electricity at a cost of \$62.6 million in state fiscal year 2005; and

WHEREAS, The Energy Star® label indicates that appliances and equipment meet all U.S. Department of Energy and Environmental Protection Agency standards for energy efficiency; and

WHEREAS, Energy Star® estimates energy and cost savings to businesses, organizations and consumers utilizing Energy Star® certified appliances and equipment of approximately \$12 billion nationally in 2005; and

WHEREAS, CT's Energy Vision called for state agencies to assume a leadership role in conservation and the use of energy efficient products and equipment.

NOW, THEREFORE, I, M. Jodi Rell, Governor of the State of Connecticut, acting by virtue of the

authority vested in me by the constitution and by the statutes of this state, do hereby **ORDER** and **DIRECT** that:

All future equipment and appliances purchased by and for executive branch state agencies shall be Energy Star® certified, provided such Energy Star® certified equipment and appliances are commercially available.

The Department of Administrative Services, in consultation with the Office of Policy and Management and the Department of Environmental Protection shall establish and publish guidelines to provide direction to all executive branch state agencies with the implementation of this Executive Order.

The Department of Administrative Services shall provide the Office of the Governor with a report assessing the effectiveness of this Executive Order within one year of the effective date of this Executive Order.

Municipal governments, political subdivisions and school districts that are not expressly subject to the requirements of this Executive Order are encouraged to comply with the provisions of this Executive Order. Such entities may seek guidance and assistance consistent with the provisions of Paragraph 2 of this Executive Order from the Departments of Administrative Services, Environmental Protection and the Office of Policy and Management.

This Order shall take effect immediately.

Dated at Hartford the ___ day of February, 2008

M. Jodi Rell,
Governor

STATE OF CONNECTICUT

BY HER EXCELLENCY

M. JODI RELL

GOVERNOR

EXECUTIVE ORDER NO. 18

WHEREAS, Connecticut is of state with a distinctive landscape and natural and historic beauty; and

WHEREAS, during the past several years there has been an increase in the number of outdoor advertising displays and billboards in Connecticut; and

WHEREAS, the outdoor advertising displays and billboards clutter our landscape and pose a potential distraction to the state's motorists; and

WHEREAS, a number of these outdoor displays and billboards are located on state owned property;

WHEREAS, many of the current contracts between the State of Connecticut and private entities allowing for the erection and/or maintenance of outdoor advertising structures, devices or displays contain renewal options; and

WHEREAS, in order to maintain the historic and natural landscape of our State it is necessary to curtail the number of outdoor advertising displays and billboards;

NOW, THEREFORE, I, M. Jodi Rell, Governor of the State of Connecticut, acting by virtue of the authority vested in me by the Constitution and the statutes of this State, do hereby **ORDER** and **DIRECT**:

1. That no new contracts for the erection and/or maintenance of outdoor advertising structures, devices or displays on state-owned property shall be executed;
2. That no renewal options in existing contracts for the erection and/or maintenance of outdoor advertising structures, devices or displays on state-owned property shall be exercised; and
3. That this Order takes effect immediately.

Dated in Hartford, Connecticut, this 6th day of February 2008.

M. Jodi Rell, Governor

By Her Excellency's Command

TITLE VI CONTRACTOR ASSURANCES

For this document Contractor means Consultant, Consulting Engineer, Second Party, or other entity doing business with the State and Contract shall mean the same as Agreement.

During the performance of this Contract, the contractor, for itself, its assignees and successors in interest (hereinafter referred to as the "Contractor") agrees as follows:

1. **Compliance with Regulations:** The Contractor shall comply with the regulations relative to nondiscrimination in federally assisted programs of the United States Department of Transportation (hereinafter, "USDOT"), Title 49, Code of Federal Regulations, Part 21, as they may be amended from time to time (hereinafter referred to as the "Regulations"), which are herein incorporated by reference and made a part of this contract.

2. **Nondiscrimination:** The Contractor, with regard to the work performed by it during the Contract, shall not discriminate on the grounds of race, color, national origin, sex, age, or disability in the selection and retention of subcontractors, including procurements of materials and leases of equipment. The Contractor shall not participate either directly or indirectly in the discrimination prohibited by Subsection 5 of the Regulations, including employment practices when the Contract covers a program set forth in Appendix B of the Regulations.

3. **Solicitations for Subcontracts, Including Procurements of Materials and Equipment:** In all solicitations either by competitive bidding or negotiation made by the Contractor for work to be performed under a subcontract, including procurements of materials or leases of equipment, each potential subcontractor or supplier shall be notified by the Contractor of the Contractor's obligations under this contract and the Regulations relative to nondiscrimination on the grounds of race, color, national origin, sex, age, or disability.

4. **Information and Reports:** The Contractor shall provide all information and reports required by the Regulations or directives issued pursuant thereto and shall permit access to its books, records, accounts, other sources of information, and its facilities as may be determined by the Connecticut Department of Transportation (ConnDOT) or the Funding Agency (FHWA, FTA and FAA) to be pertinent to ascertain compliance with such Regulations, orders, and instructions. Where any information required of a Contractor is in the exclusive possession of another who fails or refuses to furnish this information, the Contractor shall so certify to ConnDOT or the Funding Agency, as appropriate, and shall set forth what efforts it has made to obtain the information.

5. **Sanctions for Noncompliance:** In the event of the Contractor's noncompliance with the nondiscrimination provisions of this Contract, the ConnDOT shall impose such sanctions as it or the Funding Agency may determine to be appropriate, including, but not limited to:

A. Withholding contract payments until the Contractor is in-compliance; and/or

B. Cancellation, termination, or suspension of the Contract, in whole or in part.

6. **Incorporation of Provisions:** The Contractor shall include the provisions of paragraphs 1 through 5 in every subcontract, including procurements of materials and leases of equipment, unless exempt by the Regulations or directives issued pursuant thereto. The Contractor shall take such action with respect to any subcontract or procurement as the ConnDOT or the Funding Agency may direct as a means of enforcing such provisions including sanctions for noncompliance. Provided, however, that in the event a Contractor becomes involved in, or is threatened with, litigation with a subcontractor or supplier as a result of such direction, the Contractor may request the ConnDOT to enter into such litigation to protect the interests of the Funding Agency, and, in addition, the Contractor may request the United States to enter into such litigation to protect the interests of the United States.

**CONNECTICUT REQUIRED CONTRACT/AGREEMENT PROVISIONS
SPECIFIC EQUAL EMPLOYMENT OPPORTUNITY RESPONSIBILITIES**

1. General:

a) Equal employment opportunity requirements not to discriminate and to take affirmative action to assure equal employment opportunity as required by Executive Order 11246, Executive Order 11375 are set forth in Required Contract Provisions (Form PR-1273 or 1316, as appropriate) and these Special Provisions which are imposed pursuant to Section 140 of Title 23 U.S.C., as established by Section 22 of the Federal-Aid Highway Act of 1968. The requirements set forth in these Special Provisions shall constitute the specific affirmative action requirements for project activities under this contract and supplement the equal employment opportunity requirements set forth in the Required Contract Provisions.

b) "Company" refers to any entity doing business with the Connecticut Department of Transportation and includes but is not limited to the following:

Contractors and Subcontractors
Consultants and Subconsultants
Suppliers of Materials and Vendors (where applicable)
Municipalities (where applicable)
Utilities (where applicable)

c) The Company will work with the Connecticut Department of Transportation (ConnDOT) and the Federal Government in carrying out equal employment opportunity obligations and in their review of his/her activities under the contract.

d) The Company and all his/her subcontractors or subconsultants holding subcontracts not including material suppliers, of \$10,000 or more, will comply with the following minimum specific requirement activities of equal employment opportunity: (The equal employment opportunity requirements of Executive Order 11246, as set forth in volume 6, Chapter 4, Section 1, subsection 1 of the Federal-Aid Highway Program Manual, are applicable to material suppliers as well as contractors and subcontractors.) The company will include these requirements in every subcontract of \$10,000 or more with such modification of language as necessary to make them binding on the subcontractor or subconsultant.

2. Equal Employment Opportunity Policy:

The Company will develop, accept and adopt as its operating policy an Affirmative Action Plan utilizing the ConnDOT Affirmative Action Plan Guideline. This Plan shall be designed to further the provision of equal employment opportunity to all persons without regard to their race, color, religion, sex or national origin, and to promote the full realization of equal employment opportunity through a positive continuation program.

3. Equal Employment Opportunity Officer:

The Company will designate and make known to ConnDOT contracting officers an Equal Employment Opportunity Officer (hereinafter referred to as the EEO Officer) who will have the responsibility for and must be capable of effectively administering and promoting an active equal employment opportunity program and who must be assigned adequate authority and responsibility to do so.

4. **Dissemination of Policy:**

a. All members of the Company's staff who are authorized to hire, supervise, promote and discharge employees, or who recommend such action, or who are substantially involved in such action, will be made fully cognizant of, and will implement, the Company's equal employment opportunity policy and contractual responsibilities to provide equal employment opportunity in each grade and classification of employment. To ensure that the above agreement will be met, the following actions will be taken as a minimum:

(1) Periodic meetings of supervisory and personnel office employees will be conducted before the start of work and then not less often than once every six months, at which time the Company's equal employment opportunity policy and its implementation will be reviewed and explained. The meeting will be conducted by the EEO Officer or other knowledgeable company official.

(2) All new supervisor or personnel office employees will be given a thorough indoctrination by the EEO Officer or other knowledgeable company official, covering all major aspects of the Company's equal employment opportunity obligations within thirty days following their reporting for duty with the Company.

(3) All personnel who are engaged in direct recruitment for the project will be instructed by the EEO Officer or appropriate company official in the Company's procedures for locating and hiring minority group employees.

b. In order to make the Company's equal employment opportunity policy known to all employees, prospective employees and potential sources of employees, i.e., schools, employment agencies, labor unions (where appropriate), college placement officers, etc., the Company will place their equal employment opportunity policy in areas readily accessible to employees, applicants for employment and potential employees. The Company will bring the equal opportunity policy to the attention of employees through meetings, employee handbooks, or other appropriate means.

5. **Recruitment:**

a. When advertising for employees, the Company will include in all advertisements the notation: "An Equal Opportunity Employer". All such advertisements will be published in newspapers or other publications having a large circulation among minority groups in the area from which the project workforce would normally be derived. The Company shall comply with this provision and the recruitment requirements outlined in their ConnDOT approved Affirmative Action Plan.

b. The Company will, unless precluded by a valid bargaining agreement, conduct systematic and direct recruitment through public and private employee referral sources likely to yield qualified minority group applicants, including, but not limited to, State employment agencies, schools, colleges and minority group organizations. To meet this requirement, the Company will, through his/her EEO Officer, identify sources of potential minority group employees, and establish with such identified sources, procedures whereby minority group employees, and applicants may be referred to the Company for employment consideration.

In the event that the Company has a valid bargaining agreement providing for exclusive hiring hall referrals, he/she is expected to observe the provisions of that agreement to the extent that the system permits the Company's compliance with equal employment opportunity

contract provisions. (The U.S. Department of Labor has held that where implementation of such agreements have the effect of discriminating against minorities or women, or obligates the Company to do the same, such implementation violates Executive Order 11246, as amended.)

c. The Company will encourage his/her present employees to refer minority group applicants for employment by posting appropriate notices or bulletins in areas accessible to all such employees. In addition, information and procedures with regard to referring minority group applicants will be discussed with employees.

6. **Personnel Actions:**

Wages, working conditions, and employee benefits shall be established and administered, and personnel actions of every type, including hiring, upgrading, promotion, transfer, demotion, layoffs, and termination, shall be taken without regard to race, color, religion, sex, or national origin, etc. The company's personnel actions shall comply with this provision and the requirements outlined in their ConnDOT approved Affirmative Action Plan.

a. The Company will conduct periodic inspections of project sites to insure that working conditions and employee facilities do not indicate discriminatory treatment of project site personnel.

b. The Company will periodically evaluate the spread of wages paid within each classification to determine any evidence of discriminatory wage practices.

c. The Company will periodically review selected personnel actions in depth to determine whether there is evidence of discrimination. Where evidence is found, the Company will promptly take corrective action. If the review indicates that the discrimination may extend beyond the actions reviewed, such corrective action shall include all affected persons.

d. The general contract provision entitled A(76) Affirmative Action Requirements is made part of this document by reference.

7. **Training and Promotion:**

a. The Company will assist in locating, qualifying, and increasing the skills of minority group and women employees, and applicants for employment.

b. Consistent with the Company's work force requirements and as permissible under Federal and State regulations, the Company shall make full use of training programs, i.e., apprenticeship, and on-the-job training programs for the geographical area of contract performance. Where feasible, 25 percent of apprentices or trainees in each occupation shall be in their first year of apprenticeship or training. In the event the Training Special Provision is provided under this contract, this subparagraph will be superseded.

c. The Company will advise employees and applicants for employment of available training programs and the entrance requirements for each.

d. The Company will periodically review the training and promotion potential of minority group and women employees and will encourage eligible employees to apply for such training and promotion.

8. Unions:

If the Company relies in whole or in part upon unions as a source of employees, the Company will use his/her best efforts to obtain the cooperation of such unions to increase opportunities for minority groups and women within the unions, and to effect referrals by such unions of minority and female employees. Actions by the Company either directly or through a contractor's association acting as agent will include the procedures set forth below:

a. The Company will use best efforts to develop, in cooperation with the unions, joint training programs aimed toward qualifying more minority group members and women for membership in the unions and increasing the skills of minority group employees and women so that they may qualify for higher paying employment.

b. The Company will use best efforts to incorporate an Equal Opportunity clause into each union agreement to the extent that such union will be contractually bound to refer applicants without regard to their race, color, religion, sex or national origin.

c. The Company is to obtain information as to the referral practices and policies of the labor union except to the extent that such information is within the exclusive possession of the labor union and such labor union refuses to furnish such information to the Company, the Company shall so certify to the Connecticut Department of Transportation (ConnDOT) and shall set forth what efforts have been made to obtain such information.

d. In the event the union is unable to provide the Company with a reasonable flow of minority and women referrals within the time limit set forth in the collective bargaining agreement, the Company will, through independent recruitment efforts, fill the employment vacancies without regard to race, color, religion, sex, national origin; making full efforts to obtain qualified and/or qualifiable minority group persons and women. (The United States Department of Labor has held that it shall be no excuse that the union with which the contractor has a collective bargaining agreement providing for exclusive referral failed to refer minority employees.) In the event the union referral practice prevents the Company from meeting the obligations under Executive Order 11246 as amended, and these special provisions, such Company shall immediately notify ConnDOT.

9. Subcontracting:

a. The Company will use his/her best efforts to solicit bids from and to utilize minority group subcontractors, or subcontractors with meaningful minority group and female representation among their employees. Companies shall obtain lists of minority-owned construction firms from the Division of Contract compliance.

b. The Company will use its best efforts to ensure subcontractor compliance with their equal employment opportunity obligations.

10. Records and Reports:

a. The Company will keep such records as are necessary to determine compliance with equal employment opportunity obligations. The records kept by the Company will be designed to indicate:

1. The number of minority and non-minority group members and women employed in each classification on the project;

2. The progress and efforts being made in cooperation with unions to increase employment opportunities for minorities and women; (applicable only to contractors who rely in whole or in part on unions as a source of their work force),
3. The progress and efforts being made in locating, hiring, training, qualifying, and upgrading minority and female employees; and
4. The progress and efforts being made in securing the services of minority group subcontractors, or subcontractors with meaningful minority and female representation among their employees.

b. All such records must be retained for a period of three years following completion of the contract work and shall be available at reasonable times and places for inspection by authorized representatives of ConnDOT and the Federal Highway Administration.

c. The Company will submit an annual report to ConnDOT each July for the duration of the project, indicating the number of minority, women, and non-minority group employees currently engaged in each work classification required by the contract work. This information is to be reported on Form PR 1391. If on-the-job training is being required by "Training Special Provision", the Company will be required to furnish Form FHWA 1409.

11. Affirmative Action Plan

Companies with contracts, agreements or purchase orders valued at \$10,000 or more will submit a ConnDOT Affirmative Action Plan.

General Decision Number: CT100001 07/08/2011 CT1

Superseded General Decision Number: CT20080001

State: Connecticut

Construction Type: Highway

Counties: Fairfield, Litchfield, Middlesex, New Haven, Tolland and Windham Counties in Connecticut.

HIGHWAY CONSTRUCTION PROJECTS

Modification Number	Publication Date
0	03/12/2010
1	04/23/2010
2	04/30/2010
3	05/07/2010
4	06/04/2010
5	07/02/2010
6	07/16/2010
7	07/23/2010
8	07/30/2010
9	08/20/2010
10	10/08/2010
11	11/05/2010
12	04/22/2011
13	06/03/2011
14	06/10/2011
15	06/17/2011
16	07/08/2011

BRCT0001-004 04/01/2011

	Rates	Fringes
BRICKLAYER		
BRICKLAYERS, CEMENT		
MASONS, CEMENT FINISHERS,		
PLASTERERS AND STONE MASONS.	\$ 32.50	22.51

CARP0024-006 05/02/2011

LITCHFIELD COUNTY
Harwinton, Plymouth, Thomaston, Watertown
MIDDLESEX COUNTY
NEW HAVEN COUNTY
Beacon Falls, Bethany, Branford, Cheshire, East Haven,
Guilford, Hamden, Madison, Meriden, Middlebury, Naugatuck, New
Haven, North Branford, North Haven, Orange (east of Orange
Center Road and north of Route 1, and north of Route 1 and east
of the Oyster River), Prospect, Southbury, Wallingford,
Waterbury, West Haven, Wolcott, Woodbridge
TOLLAND COUNTY
Andover, Columbia, Coventry, Hebron, Mansfield, Union,
Willington
WINDHAM COUNTY

	Rates	Fringes
Carpenters:		
Carpenters, Piledrivers.....	\$ 29.11	20.29
Diver Tenders.....	\$ 29.11	20.29
Divers.....	\$ 37.57	20.29

CARP0043-004 05/02/2011

	Rates	Fringes
Carpenters: (TOLLAND COUNTY		
Bolton, Ellington, Somers,		
Tolland, Vernon)		
CARPENTERS, PILEDRIVERS.....	\$ 29.11	20.29
DIVER TENDERS.....	\$ 29.11	20.29
DIVERS.....	\$ 37.57	20.29

CARP0210-002 05/02/2011

	Rates	Fringes
Carpenters:		
CARPENTERS, PILEDRIVERS.....	\$ 29.11	20.29
DIVER TENDERS.....	\$ 29.11	20.29
DIVERS.....	\$ 37.57	20.29
FAIRFIELD COUNTY		

Bethel, Bridgeport, Brookfield, Danbury, Darien, Easton, Fairfield, Greenwich, Monroe, New Canaan, New Fairfield, Newtown, Norwalk, Redding, Ridgefield, Shelton, Sherman, Stamford, Stratford, Trumbull, Weston, Westport, Wilton;

LITCHFIELD COUNTY

Barkhamstead, Bethlehem, Bridgewater, Canaan, Colebrook, Cornwall, Goshen, Kent, Litchfield, Morris, New Hartford, New Milford, Norfolk, North Canaan, Roxbury, Salisbury, Sharon, Torrington, Warren, Washington, Winchester, Woodbury;

NEW HAVEN COUNTY

Ansonia, Derby, Milford, Orange (west of Orange Center Road and south of Route 1 and west of the Oyster River), Oxford, Seymour;

ELEC0003-002 05/08/2008

	Rates	Fringes
Electricians		
FAIRFIELD COUNTY		
Darien, Greenwich, New Canaan, Stamford.....	\$ 44.75	30.42

* ELEC0035-001 06/01/2011

	Rates	Fringes
Electricians:		
MIDDLESEX COUNTY (Cromwell, Middlefield, Middleton and Portland); TOLLAND COUNTY; WINDHAM COUNTY.....	\$ 36.40	21.31

ELEC0090-002 06/01/2011

	Rates	Fringes
Electricians:.....	\$ 35.70	21.52
LITCHFIELD COUNTY		

Plymouth Township;

MIIDDLESEX COUNTY

Chester, Clinton, Deep River, Durham, East Haddam, East Hampton, Essex, Haddam, Killingworth, Old Saybrook, Westbrook;

NEW HAVEN COUNTY

All Townships excluding Beacon Falls, Middlebury, Milford, Naugatuck, Oxford, Prospect, Seymour, Southbury, Waterbury and Wolcott.

ELEC0488-002 06/01/2010

	Rates	Fringes
Electricians.....	\$ 34.80	21.05
FAIRFIELD COUNTY		

Bethel, Bridgeport, Brookfield, Danbury, Easton, Fairfield, Monroe, New Fairfield, Newtown, Redding, Ridgefield, Shelton, Sherman, Stratford, Trumbull;

LITCHFIELD COUNTY

Except Plymouth;

NEW HAVEN COUNTY

Beacon Falls, Middlebury, Milford, Naugatuck, Oxford,
Prospect, Seymour, Southbury, Waterbury and Wolcott

ENGI0478-001 05/07/2011

	Rates	Fringes
Power equipment operators:		
GROUP 1.....	\$ 35.05	19.40
GROUP 2.....	\$ 34.73	19.40
GROUP 3.....	\$ 33.99	19.40
GROUP 4.....	\$ 33.60	19.40
GROUP 5.....	\$ 33.01	19.40
GROUP 6.....	\$ 32.70	19.40
GROUP 7.....	\$ 32.36	19.40
GROUP 8.....	\$ 31.96	19.40
GROUP 9.....	\$ 31.53	19.40
GROUP 10.....	\$ 29.49	19.40
GROUP 11.....	\$ 29.49	19.40
GROUP 12.....	\$ 29.43	19.40
GROUP 13.....	\$ 30.96	19.40
GROUP 14.....	\$ 28.85	19.40
GROUP 15.....	\$ 28.54	19.40
GROUP 16.....	\$ 27.71	19.40
GROUP 17.....	\$ 27.30	19.40
GROUP 18.....	\$ 26.65	19.40

Hazardous waste premium \$3.00 per hour over classified rate.

Crane with boom, including jib, 150 feet - \$1.50 extra.
Crane with boom, including jib, 200 feet - \$2.50 extra.
Crane with boom, including jib, 250 feet - \$5.00 extra.
Crane with boom, including jib, 300 feet - \$7.00 extra.
Crane with boom, including jib, 400 feet - \$10.00 extra

a. PAID HOLIDAYS: New Year's Day, Good Friday, Memorial Day, Independence Day, Labor Day, Thanksgiving Day and Christmas Day, provided the employee works 3 days during the week in which the holiday falls, if scheduled, and if scheduled, the working day before and the working day after the holiday.

POWER EQUIPMENT OPERATORS CLASSIFICATIONS

GROUP 1: Crane handling or erecting structural steel or stone, hoisting engineer (2 drums or over), front end loader (7 cubic yards or over), work boat 26 ft. and over.

GROUP 2: Cranes (100 ton capacity & over), Excavator over 2 cubic yards, piledriver (\$3.00 premium when operator controls hammer).

GROUP 3: Excavator, cranes (under 100 ton rated capacity), gradall, master mechanic, hoisting engineer (all types of equipment where a drum and cable are used to hoist or drag material regardless of motive power or operation) Rubber Tire Excavator (drott 1085 or similar); Grader Operator; Bulldozer Fine Grade (slopes, shaping, laser or GPS, etc.)

GROUP 4: Trenching machines, lighter derrick, concrete finishing machine, CMI machine or similar, Koehring Loader (skooper).

GROUP 5: Specialty railroad equipment, asphalt spreader, asphalt reclaiming machine, line grider, concrete pumps, drills with self contained power units, boring machine, post hole digger, auger, pounder, well digger, milling machine (over 24' mandrel), side boom, combination hoe and loader, directional driller.

GROUP 6: Front end loader (3 cu. yds. up to 7 cu. yards), bulldozer (Rough grade dozer) .

GROUP 7: Asphalt roller, concrete saws and cutters (ride on types), Vermeer concrete cutter, stump grinder, scraper, snooper, skidder, milling machine (24" and under Mandrel).

GROUP 8: Mechanic, grease truck operator, hydoblaster,

barrier mover, power stone spreader, welder, work boat under 26 ft. transfer machine.

GROUP 9: Front end loader (under 3 cubic yards), skid steer loader (regardless of attachments), bobcat or similar, forklift, power chipper, landscape equipment (including hydroseeder).

GROUP 10: Vibratory hammer, ice machine, diesel & air, hammer, etc.

GROUP 11: Conveyor, earth roller, power pavement breaker (whiphammer), robot demolition equipment.

GROUP 12: Wellpoint operator.

GROUP 13: Portable asphalt plant operator, portable concrete plant operator, portable crusher plant operator.

GROUP 14: Compressor battery operator.

GROUP 15: Power Safety boat, Vacuum truck, Zim mixer, Sweeper; (Minimum for any job requiring a CDL license) .

GROUP 16: Elevator operator, tow motor operator (solid tire no rough terrain).

GROUP 17: Generator operator, compressor operator, pump operator, welding machine operator; Heater operator.

GROUP 18: Maintenance engineer.

IRON0015-002 06/28/2010

	Rates	Fringes
Ironworkers: (Reinforcing, Structural and Precast Concrete Erection).....	\$ 33.00	26.58+a

a. PAID HOLIDAY: Labor Day provided employee has been on the payroll for the 5 consecutive work days prior to Labor Day.

LABO0056-003 04/03/2011

	Rates	Fringes
Laborers:		
GROUP 1.....	\$ 25.75	15.60
GROUP 2.....	\$ 26.00	15.60
GROUP 3.....	\$ 26.25	15.60
GROUP 4.....	\$ 26.75	15.60
GROUP 5.....	\$ 27.50	15.60
GROUP 6.....	\$ 27.75	15.60
GROUP 7.....	\$ 16.00	15.60

LABORERS CLASSIFICATIONS

GROUP 1: Laborers (Unskilled), acetylene burner, concrete specialist

GROUP 2: Chain saw operators, fence and guard rail erectors, pneumatic tool operators and powdermen.

GROUP 3: Pipelayers, Jackhammer/Pavement breaker (handheld), mason tenders/catch basin builders, asphalt rakers, air track operators, block paver and curb setter

GROUP 4: Asbestos/lead removal

GROUP 5: Blasters

GROUP 6: Toxic waste remover

GROUP 7: Traffic control signalman

PAIN0011-001 06/01/2011

	Rates	Fringes
--	-------	---------

Painters:
 Blast and Spray.....\$ 32.17 16.35
 Brush and Roll.....\$ 29.17 16.35
 Tanks, Towers, Swing.....\$ 31.17 16.35

 PAIN0011-003 06/01/2011

Rates Fringes

Painters: (BRIDGE
 CONSTRUCTION)
 Brush, Roller, Blasting
 (Sand, Water, etc.) Spray...\$ 41.35 16.35

 TEAM0064-001 04/03/2011

Rates Fringes

Truck drivers:
 2 Axle Ready Mix.....\$ 27.98 15.71+a
 2 Axle.....\$ 27.88 15.71+a
 3 Axle Ready Mix.....\$ 28.03 15.71+a
 3 Axle.....\$ 27.98 15.71+a
 4 Axle Ready Mix.....\$ 28.13 15.71+a
 4 Axle.....\$ 28.08 15.71+a
 Heavy Duty Trailer 40 tons
 and over.....\$ 28.33 15.71+a
 Heavy Duty Trailer up to
 40 tons.....\$ 28.08 15.71+a
 Specialized (Earth moving
 equipment other than
 conventional type on-the-
 road trucks and semi-
 trailers, including
 Euclids).....\$ 28.13 15.71+a

Hazardous waste removal work receives additional \$1.25 per hour.

a. PAID HOLIDAYS: New Year's Day, Memorial Day, Independence Day, Labor Day, Thanksgiving Day, Christmas Day and Good Friday, provided the employee has at least 31 calendar days of service and works the last scheduled day before and the first scheduled day after the holiday, unless excused.

 WELDERS - Receive rate prescribed for craft performing operation to which welding is incidental.
 =====

Unlisted classifications needed for work not included within the scope of the classifications listed may be added after award only as provided in the labor standards contract clauses (29CFR 5.5 (a) (1) (ii)).

 In the listing above, the "SU" designation means that rates listed under the identifier do not reflect collectively bargained wage and fringe benefit rates. Other designations indicate unions whose rates have been determined to be prevailing.

WAGE DETERMINATION APPEALS PROCESS

1.) Has there been an initial decision in the matter? This can be:

- * an existing published wage determination
- * a survey underlying a wage determination
- * a Wage and Hour Division letter setting forth a position on a wage determination matter
- * a conformance (additional classification and rate) ruling

On survey related matters, initial contact, including requests for summaries of surveys, should be with the Wage and Hour Regional Office for the area in which the survey was conducted because those Regional Offices have responsibility for the Davis-Bacon survey program. If the response from this initial

contact is not satisfactory, then the process described in 2.) and 3.) should be followed.

With regard to any other matter not yet ripe for the formal process described here, initial contact should be with the Branch of Construction Wage Determinations. Write to:

Branch of Construction Wage Determinations
Wage and Hour Division
U.S. Department of Labor
200 Constitution Avenue, N.W.
Washington, DC 20210

2.) If the answer to the question in 1.) is yes, then an interested party (those affected by the action) can request review and reconsideration from the Wage and Hour Administrator (See 29 CFR Part 1.8 and 29 CFR Part 7). Write to:

Wage and Hour Administrator
U.S. Department of Labor
200 Constitution Avenue, N.W.
Washington, DC 20210

The request should be accompanied by a full statement of the interested party's position and by any information (wage payment data, project description, area practice material, etc.) that the requestor considers relevant to the issue.

3.) If the decision of the Administrator is not favorable, an interested party may appeal directly to the Administrative Review Board (formerly the Wage Appeals Board). Write to:

Administrative Review Board
U.S. Department of Labor
200 Constitution Avenue, N.W.
Washington, DC 20210

4.) All decisions by the Administrative Review Board are final.

=====
END OF GENERAL DECISION

General Decision Number: CT100003 08/26/2011 CT3

Superseded General Decision Number: CT20080003

State: Connecticut

Construction Type: Highway

County: New London County in Connecticut.

HIGHWAY CONSTRUCTION PROJECTS

Modification Number	Publication Date
0	03/12/2010
1	04/23/2010
2	04/30/2010
3	05/07/2010
4	06/04/2010
5	06/25/2010
6	07/02/2010
7	07/23/2010
8	07/30/2010
9	08/20/2010
10	10/08/2010
11	11/05/2010
12	04/22/2011
13	06/10/2011
14	06/17/2011
15	07/08/2011
16	08/26/2011

BRCT0001-003 04/01/2011

	Rates	Fringes
BRICKLAYER		
BRICKLAYERS, CEMENT MASONS, CEMENT FINISHERS, PLASTERERS, STONE MASONS....	\$ 32.50	22.51

CARP0024-002 05/02/2011

	Rates	Fringes
Carpenters:		
Carpenters, Piledrivers.....	\$ 29.11	20.29
Diver Tenders.....	\$ 29.11	20.29
Divers.....	\$ 37.57	20.29

* ELEC0035-003 06/01/2011

	Rates	Fringes
Electricians:		
Bozrah, Colchester, Franklin, Griswold, Lebanon, Ledyard, Lisbon, Montville, North Stonington, Norwich, Preston, Salem, Sprague, Stonington and Voluntown....	\$ 36.40	21.31

ELEC0090-003 06/01/2010

East Lyme, Groton, New London, Old Lyme, Waterford, plus the part of Ledyard wherein the property of the Submarine Base is located

	Rates	Fringes
ELECTRICIAN.....	\$ 35.20	20.51

ENGI0478-002 05/07/2011

	Rates	Fringes
Power equipment operators:		
GROUP 1.....	\$ 35.05	19.40+a
GROUP 2.....	\$ 34.73	19.40+a

GROUP 3\$	33.99	19.40+a
GROUP 4\$	33.60	19.40+a
GROUP 5\$	33.01	19.40+a
GROUP 6\$	32.70	19.40+a
GROUP 7\$	32.36	19.40+a
GROUP 8\$	31.96	19.40+a
GROUP 9\$	31.53	19.40+a
GROUP 10\$	29.49	19.40+a
GROUP 11\$	29.49	19.40+a
GROUP 12\$	29.43	19.40+a
GROUP 13\$	30.96	19.40+a
GROUP 14\$	28.85	19.40+a
GROUP 15\$	28.54	19.40+a
GROUP 16\$	27.71	19.40+a
GROUP 17\$	27.30	19.40+a
GROUP 18\$	26.65	19.40+a

Hazardous waste premium \$3.00 per hour over classified rate.

Crane with 150 ft. boom (including jib): \$1.50 extra.
 Crane with 200 ft. boom (including jib): \$2.50 extra.
 Crane with 250 ft. boom (including jib): \$5.00 extra.
 Crane with 300 ft. boom (including jib): \$7.00 extra.
 Crane with 400 ft. boom (including jib); \$10.00 extra.

a. PAID HOLIDAYS: New Year's Day, Good Friday, Memorial Day, Independence Day, Labor Day, Thanksgiving Day and Christmas Day, provided the employee works 3 days during the week in which the holiday falls, if scheduled, and if scheduled, the working day before and the working day after the holiday.

POWER EQUIPMENT OPERATORS CLASSIFICATIONS

GROUP 1: Crane Handling or Erecting Structural Steel or tone; Hoisting Engineer (2 drums or over); Front End Loader (7 cubic yards or over) Work Boat 26 ft. & over.

GROUP 2: Cranes (100 ton rated capacity and over); Excavator over 2 cubic yards; Piledriver (\$3.00 premium when operator controls hammer).

GROUP 3: Excavator; Cranes (under 100 ton rated capacity), Gradall; Master Mechanic; Hoisting Engineer (all types of equipment where a drum and cable are used to hoist or drag material regardless of motive power of operation), Rubber tire Excavator (Drott-1085 or similar); Grader Operator; Bulldozer Fine Grade (slopes. shaping, laser or GPS, etc.)

GROUP 4: Trenching machines; Lighter Derrick; Concrete Finishing Machine, cmi Machine or Similar; Koehring Loader Skooper).

GROUP 5: Specialty Railroad Equipment; Asphalt Spreader; Asphalt Reclaiming achine; Line Grinder; Concrete Pumps; Drills with Self Contained Power Units; Boring Machine; Post Hole Digger; Auger; Pounder; Well Digger; Milling Machine (over 24" Mandrell); Side Boom; Combination Hoe and Loader; Directional Driller.

GROUP 6: Front End Loader (3 cu. yds. up to 7 cubic yards); Bulldozer (Rough grade dozer).

GROUP 7: Asphalt Roller; Concrete Saws and Cutters (Ride on Types); Vermeer Concrete Cutter; Stump Grinder; Scraper; Snooper; Skidder; Milling Machine (24" and Under Mandrel).

GROUP 8: Mechanic; Grease Truck Operator; Hydroblaster; Barrier Mover; Power Stone Spreader; Welder; Work Boat Under 26 ft.; Transfer Machine.

GROUP 9: Front End Loader (under 3 cubic yards); Skid Steer Loader (regardless of attachments); (Bobcat or similar); Fork Lift; Power Chipper; Landscape Equipment (including Hydroseeder).

GROUP 10: Vibratory Hammer, Ice Machine, Diesel and Air Hammer, etc.

GROUP 11: Conveyor; Earth Roller; Power Pavement Breaker (Whiphammer); Robot Demolition Equipment.

GROUP 12: Wellpoint Operator.

GROUP 13: Portable Asphalt Plant Operator; Portable Concrete Plant Operator; Portable Crusher Plant Operator.

GROUP 14: Compressor Battery Operator.

GROUP 15: Power Safety Boat; Vacuum Truck; Zim Mixer; Sweeper; (Minimum for any job requiring a CDL License)

GROUP 16: Elevator Operator; Tow Motor Operator (Solid Tire No Rough Terrain).

GROUP 17: Generator Operator; Compressor Operator; Pump Operator; Welding Machine Operator; Heater operator.

GROUP 18: Maintenance Engineer.

IRON0015-003 06/28/2010

	Rates	Fringes
Ironworkers: (Reinforcing & Structural).....	\$ 33.00	26.58+a

a. PAID HOLIDAY: Labor Day provided employee has been on the payroll for the 5 consecutive work days prior to Labor Day.

LABO0056-003 04/03/2011

	Rates	Fringes
Laborers:		
GROUP 1.....	\$ 25.75	15.60
GROUP 2.....	\$ 26.00	15.60
GROUP 3.....	\$ 26.25	15.60
GROUP 4.....	\$ 26.75	15.60
GROUP 5.....	\$ 27.50	15.60
GROUP 6.....	\$ 27.75	15.60
GROUP 7.....	\$ 16.00	15.60

LABORERS CLASSIFICATIONS

GROUP 1: Laborers (Unskilled), acetylene burner, concrete specialist

GROUP 2: Chain saw operators, fence and guard rail erectors, pneumatic tool operators and powdermen.

GROUP 3: Pipelayers, Jackhammer/Pavement breaker (handheld), mason tenders/catch basin builders, asphalt rakers, air track operators, block paver and curb setter

GROUP 4: Asbestos/lead removal

GROUP 5: Blasters

GROUP 6: Toxic waste remover

GROUP 7: Traffic control signalman

PAIN0011-002 06/01/2011

	Rates	Fringes
Painters:		
Blast and Spray.....	\$ 32.17	16.35
Brush and Roll.....	\$ 29.17	16.35
Tanks, Towers, Swing.....	\$ 31.17	16.35

PAIN0011-003 06/01/2011

	Rates	Fringes
Painters: (BRIDGE CONSTRUCTION)		
Brush, Roller, Blasting (Sand, Water, etc.) Spray...	\$ 41.35	16.35

	Rates	Fringes
Truck drivers:		
2 Axle Ready Mix.....	\$ 27.98	15.71+a
2 Axle.....	\$ 27.88	15.71+a
3 Axle Ready Mix.....	\$ 28.03	15.71+a
3 Axle.....	\$ 27.98	15.71+a
4 Axle Ready Mix.....	\$ 28.13	15.71+a
4 Axle.....	\$ 28.08	15.71+a
Heavy Duty Trailer 40 tons and over.....	\$ 28.33	15.71+a
Heavy Duty Trailer up to 40 tons.....	\$ 28.08	15.71+a
Specialized (Earth moving equipment other than conventional type on-the- road trucks and semi- trailers, including Euclids).....	\$ 28.13	15.71+a

Hazardous waste removal work receives additional \$1.25 per hour.

a. PAID HOLIDAYS: New Year's Day, Memorial Day, Independence Day, Labor Day, Thanksgiving Day, Christmas Day and Good Friday, provided the employee has at least 31 calendar days of service and works the last scheduled day before and the first scheduled day after the holiday, unless excused.

WELDERS - Receive rate prescribed for craft performing operation to which welding is incidental.

Unlisted classifications needed for work not included within the scope of the classifications listed may be added after award only as provided in the labor standards contract clauses (29CFR 5.5 (a) (1) (ii)).

In the listing above, the "SU" designation means that rates listed under the identifier do not reflect collectively bargained wage and fringe benefit rates. Other designations indicate unions whose rates have been determined to be prevailing.

WAGE DETERMINATION APPEALS PROCESS

1.) Has there been an initial decision in the matter? This can be:

- * an existing published wage determination
- * a survey underlying a wage determination
- * a Wage and Hour Division letter setting forth a position on a wage determination matter
- * a conformance (additional classification and rate) ruling

On survey related matters, initial contact, including requests for summaries of surveys, should be with the Wage and Hour Regional Office for the area in which the survey was conducted because those Regional Offices have responsibility for the Davis-Bacon survey program. If the response from this initial contact is not satisfactory, then the process described in 2.) and 3.) should be followed.

With regard to any other matter not yet ripe for the formal process described here, initial contact should be with the Branch of Construction Wage Determinations. Write to:

Branch of Construction Wage Determinations
Wage and Hour Division
U.S. Department of Labor
200 Constitution Avenue, N.W.
Washington, DC 20210

2.) If the answer to the question in 1.) is yes, then an

interested party (those affected by the action) can request review and reconsideration from the Wage and Hour Administrator (See 29 CFR Part 1.8 and 29 CFR Part 7). Write to:

Wage and Hour Administrator
U.S. Department of Labor
200 Constitution Avenue, N.W.
Washington, DC 20210

The request should be accompanied by a full statement of the interested party's position and by any information (wage payment data, project description, area practice material, etc.) that the requestor considers relevant to the issue.

3.) If the decision of the Administrator is not favorable, an interested party may appeal directly to the Administrative Review Board (formerly the Wage Appeals Board). Write to:

Administrative Review Board
U.S. Department of Labor
200 Constitution Avenue, N.W.
Washington, DC 20210

4.) All decisions by the Administrative Review Board are final.

=====

END OF GENERAL DECISION

General Decision Number: CT100004 07/08/2011 CT4

Superseded General Decision Number: CT20080004

State: Connecticut

Construction Type: Highway

County: Hartford County in Connecticut.

HIGHWAY CONSTRUCTION PROJECTS

Modification Number	Publication Date
0	03/12/2010
1	04/23/2010
2	04/30/2010
3	05/07/2010
4	06/04/2010
5	06/25/2010
6	07/02/2010
7	07/23/2010
8	07/30/2010
9	08/20/2010
10	10/08/2010
11	11/05/2010
12	04/22/2011
13	06/10/2011
14	06/17/2011
15	07/08/2011

BRCT0001-003 04/01/2011

	Rates	Fringes
BRICKLAYER BRICKLAYERS, CEMENT MASONS, CEMENT FINISHERS, PLASTERERS, STONE MASONS....	\$ 32.50	22.51

CARP0024-005 05/02/2011

	Rates	Fringes
Carpenters: (Berlin, Bristol, Burlington, Canton, Marlborough, New Britain, Newington, Plainville, Southington)		
CARPENTERS; PILEDRIVERS.....	\$ 29.11	20.29
DIVER TENDERS.....	\$ 29.11	20.29
DIVERS.....	\$ 37.57	20.29

CARP0043-003 05/02/2011

	Rates	Fringes
Carpenters: (Avon, Bloomfield, East Granby, East Hartford, East Windsor, Enfield, Farmington, Glastonbury, Granby, Hartford, hartland, Manchester, Rocky Hill, Simsbury, South Windsor, Suffield, West Hartford, Wethersfield, Windsor, Windsor Locks)		
CARPENTERS; PILEDRIVERS.....	\$ 29.11	20.29
DIVER TENDERS.....	\$ 29.11	20.29
DIVERS.....	\$ 37.57	20.29

* ELEC0035-002 06/01/2011

	Rates	Fringes
Electricians: Entire County, excluding Berlin, Bristol, Hartland, New Britain, Newington, Plainville and Southington..	\$ 36.40	21.31

ELEC0090-001 06/01/2010

	Rates	Fringes
Electricians:		
Berlin, Bristol, New		
Britain, Newington,		
Plainville, Southington.....	\$ 35.20	20.51

ELEC0488-004 06/01/2010

	Rates	Fringes
Electricians:.....	\$ 34.80	21.05
Hartland Township.....	\$ 34.80	19.80

ENGI0478-002 05/07/2011

	Rates	Fringes
Power equipment operators:		
GROUP 1.....	\$ 35.05	19.40+a
GROUP 2.....	\$ 34.73	19.40+a
GROUP 3.....	\$ 33.99	19.40+a
GROUP 4.....	\$ 33.60	19.40+a
GROUP 5.....	\$ 33.01	19.40+a
GROUP 6.....	\$ 32.70	19.40+a
GROUP 7.....	\$ 32.36	19.40+a
GROUP 8.....	\$ 31.96	19.40+a
GROUP 9.....	\$ 31.53	19.40+a
GROUP 10.....	\$ 29.49	19.40+a
GROUP 11.....	\$ 29.49	19.40+a
GROUP 12.....	\$ 29.43	19.40+a
GROUP 13.....	\$ 30.96	19.40+a
GROUP 14.....	\$ 28.85	19.40+a
GROUP 15.....	\$ 28.54	19.40+a
GROUP 16.....	\$ 27.71	19.40+a
GROUP 17.....	\$ 27.30	19.40+a
GROUP 18.....	\$ 26.65	19.40+a

Hazardous waste premium \$3.00 per hour over classified rate.

- Crane with 150 ft. boom (including jib): \$1.50 extra.
- Crane with 200 ft. boom (including jib): \$2.50 extra.
- Crane with 250 ft. boom (including jib): \$5.00 extra.
- Crane with 300 ft. boom (including jib): \$7.00 extra.
- Crane with 400 ft. boom (including jib); \$10.00 extra.

a. PAID HOLIDAYS: New Year's Day, Good Friday, Memorial Day, Independence Day, Labor Day, Thanksgiving Day and Christmas Day, provided the employee works 3 days during the week in which the holiday falls, if scheduled, and if scheduled, the working day before and the working day after the holiday.

POWER EQUIPMENT OPERATORS CLASSIFICATIONS

GROUP 1: Crane Handling or Erecting Structural Steel or tone; Hoisting Engineer (2 drums or over); Front End Loader (7 cubic yards or over) Work Boat 26 ft. & over.

GROUP 2: Cranes (100 ton rated capacity and over); Excavator over 2 cubic yards; Piledriver (\$3.00 premium when operator controls hammer).

GROUP 3: Excavator; Cranes (under 100 ton rated capacity), Gradall; Master Mechanic; Hoisting Engineer (all types of equipment where a drum and cable are used to hoist or drag material regardless of motive power of operation), Rubber tire Excavator (Drott-1085 or similar); Grader Operator; Bulldozer Fine Grade (slopes. shaping, laser or GPS, etc.)

GROUP 4: Trenching machines; Lighter Derrick; Concrete Finishing Machine, cmi Machine or Similar; Koehring Loader Skooper).

GROUP 5: Specialty Railroad Equipment; Asphalt Spreader; Asphalt Reclaiming achine; Line Grinder; Concrete Pumps; Drills with Self Contained Power Units; Boring Machine; Post Hole Digger; Auger; Pounder; Well Digger; Milling Machine (over 24" Mandrell); Side Boom; Combination Hoe and

Loader; Directional Driller.

GROUP 6: Front End Loader (3 cu. yds. up to 7 cubic yards); Bulldozer (Rough grade dozer).

GROUP 7: Asphalt Roller; Concrete Saws and Cutters (Ride on Types); Vermeer Concrete Cutter; Stump Grinder; Scraper; Snooper; Skidder; Milling Machine (24" and Under Mandrel).

GROUP 8: Mechanic; Grease Truck Operator; Hydroblaster; Barrier Mover; Power Stone Spreader; Welder; Work Boat Under 26 ft.; Transfer Machine.

GROUP 9: Front End Loader (under 3 cubic yards); Skid Steer Loader (regardless of attachments); (Bobcat or similar); Fork Lift; Power Chipper; Landscape Equipment (including Hydroseeder).

GROUP 10: Vibratory Hammer, Ice Machine, Diesel and Air Hammer, etc.

GROUP 11: Conveyor; Earth Roller; Power Pavement Breaker (Whiphammer); Robot Demolition Equipment.

GROUP 12: Wellpoint Operator.

GROUP 13: Portable Asphalt Plant Operator; Portable Concrete Plant Operator; Portable Crusher Plant Operator.

GROUP 14: Compressor Battery Operator.

GROUP 15: Power Safety Boat; Vacuum Truck; Zim Mixer; Sweeper; (Minimum for any job requiring a CDL License)

GROUP 16: Elevator Operator; Tow Motor Operator (Solid Tire No Rough Terrain).

GROUP 17: Generator Operator; Compressor Operator; Pump Operator; Welding Machine Operator; Heater operator.

GROUP 18: Maintenance Engineer.

IRON0015-002 06/28/2010

	Rates	Fringes
Ironworkers: (Reinforcing, Structural and Precast Concrete Erection).....	\$ 33.00	26.58+a

a. PAID HOLIDAY: Labor Day provided employee has been on the payroll for the 5 consecutive work days prior to Labor Day.

LABO0056-003 04/03/2011

	Rates	Fringes
Laborers:		
GROUP 1.....	\$ 25.75	15.60
GROUP 2.....	\$ 26.00	15.60
GROUP 3.....	\$ 26.25	15.60
GROUP 4.....	\$ 26.75	15.60
GROUP 5.....	\$ 27.50	15.60
GROUP 6.....	\$ 27.75	15.60
GROUP 7.....	\$ 16.00	15.60

LABORERS CLASSIFICATIONS

GROUP 1: Laborers (Unskilled), acetylene burner, concrete specialist

GROUP 2: Chain saw operators, fence and guard rail erectors, pneumatic tool operators and powdermen.

GROUP 3: Pipelayers, Jackhammer/Pavement breaker (handheld), mason tenders/catch basin builders, asphalt rakers, air track operators, block paver and curb setter

GROUP 4: Asbestos/lead removal

GROUP 5: Blasters

GROUP 6: Toxic waste remover

GROUP 7: Traffic control signalman

PAIN0011-003 06/01/2011

	Rates	Fringes
Painters: (BRIDGE CONSTRUCTION)		
Brush, Roller, Blasting (Sand, Water, etc.) Spray...	\$ 41.35	16.35

PAIN0011-004 06/01/2011

	Rates	Fringes
Painters:		
Blast and Spray.....	\$ 32.17	16.35
Brush and Roll.....	\$ 29.17	16.35
Tanks, Towers, Swing.....	\$ 31.17	16.35

TEAM0064-005 04/03/2011

	Rates	Fringes
Truck drivers:		
2 Axle Ready Mix.....	\$ 27.98	15.71+a
2 Axle.....	\$ 27.88	15.71+a
3 Axle Ready Mix.....	\$ 28.03	15.71+a
3 Axle.....	\$ 27.98	15.71+a
4 Axle Ready Mix.....	\$ 28.13	15.71+a
4 Axle.....	\$ 28.08	15.71+a
Heavy Duty Trailer 40 tons and over.....	\$ 28.33	15.71+a
Heavy Duty Trailer up to 40 tons.....	\$ 28.08	15.71+a
Specialized (Earth moving equipment other than conventional type on-the-road trucks and semi-trailers, including Euclids).....	\$ 28.13	15.71+a

Hazardous waste removal work receives additional \$1.25 per hour.

a. PAID HOLIDAYS: New Year's Day, Memorial Day, Independence Day, Labor Day, Thanksgiving Day, Christmas Day and Good Friday, provided the employee has at least 31 calendar days of service and works the last scheduled day before and the first scheduled day after the holiday, unless excused.

WELDERS - Receive rate prescribed for craft performing operation to which welding is incidental.
=====

Unlisted classifications needed for work not included within the scope of the classifications listed may be added after award only as provided in the labor standards contract clauses (29CFR 5.5 (a) (1) (ii)).

In the listing above, the "SU" designation means that rates listed under the identifier do not reflect collectively bargained wage and fringe benefit rates. Other designations indicate unions whose rates have been determined to be prevailing.

WAGE DETERMINATION APPEALS PROCESS

1.) Has there been an initial decision in the matter? This can be:

* an existing published wage determination

- * a survey underlying a wage determination
- * a Wage and Hour Division letter setting forth a position on a wage determination matter
- * a conformance (additional classification and rate) ruling

On survey related matters, initial contact, including requests for summaries of surveys, should be with the Wage and Hour Regional Office for the area in which the survey was conducted because those Regional Offices have responsibility for the Davis-Bacon survey program. If the response from this initial contact is not satisfactory, then the process described in 2.) and 3.) should be followed.

With regard to any other matter not yet ripe for the formal process described here, initial contact should be with the Branch of Construction Wage Determinations. Write to:

Branch of Construction Wage Determinations
Wage and Hour Division
U.S. Department of Labor
200 Constitution Avenue, N.W.
Washington, DC 20210

2.) If the answer to the question in 1.) is yes, then an interested party (those affected by the action) can request review and reconsideration from the Wage and Hour Administrator (See 29 CFR Part 1.8 and 29 CFR Part 7). Write to:

Wage and Hour Administrator
U.S. Department of Labor
200 Constitution Avenue, N.W.
Washington, DC 20210

The request should be accompanied by a full statement of the interested party's position and by any information (wage payment data, project description, area practice material, etc.) that the requestor considers relevant to the issue.

3.) If the decision of the Administrator is not favorable, an interested party may appeal directly to the Administrative Review Board (formerly the Wage Appeals Board). Write to:

Administrative Review Board
U.S. Department of Labor
200 Constitution Avenue, N.W.
Washington, DC 20210

4.) All decisions by the Administrative Review Board are final.

=====
END OF GENERAL DECISION

U.S. Department of Labor
200 Constitution Avenue, N.W.
Washington, DC 20210

The request should be accompanied by a full statement of the interested party's position and by any information (wage payment data, project description, area practice material, etc.) that the requestor considers relevant to the issue.

3.) If the decision of the Administrator is not favorable, an interested party may appeal directly to the Administrative Review Board (formerly the Wage Appeals Board). Write to:

Administrative Review Board
U.S. Department of Labor
200 Constitution Avenue, N.W.
Washington, DC 20210

4.) All decisions by the Administrative Review Board are final.

=====
END OF GENERAL DECISION

General Decision Number: CT100008 01/21/2011 CT8

Superseded General Decision Number: CT20080008

State: Connecticut

Construction Type: Heavy Dredging

Counties: Connecticut Statewide.

CONNECTICUT

ALL DREDGING, EXCEPT SELF-PROPELLED HOPPER DREDGES, ON THE ATLANTIC OCEAN AND TRIBUTARY WATERS EMPTYING INTO THE ATLANTIC OCEAN.

Modification Number	Publication Date
0	03/12/2010
1	07/16/2010
2	01/21/2011

* ENGI0025-001 10/01/2009

STATEWIDE

	Rates	Fringes
Dredging:		
CLASS A.....	\$ 32.89	8.05+a+b
CLASS B1.....	\$ 28.49	8.05+a+b
CLASS B2.....	\$ 26.84	8.05+a+b
CLASS C1(a).....	\$ 25.55	8.05+a+b
CLASS C1.....	\$ 26.14	8.05+a+b
CLASS C2.....	\$ 25.29	8.05+a+b
CLASS D(a).....	\$ 20.43	8.05+a+b
CLASS D.....	\$ 21.09	8.05+a+b

CLASSIFICATIONS:

- CLASS A: Lead Dredgeman, Operator, Leverman, Licensed Tug Operator over 1000 HP
- CLASS B1: Derrick Operator, Spider/Spill Barge Operator, Engineer, Electrician. Chief Welder, Cheif Mate, Fill Placer, Operator II, Maintenance Engineer, Licensed Boat Operator
- CLASS B2: Licensed Boat Operator, Certified Welder.
- CLASS C1: Mate, Drag Barge Operator, Steward, Assistant Fill Placer.
- CLASS C1(a): Welder.
- CLASS C2: Boat Operator
- CLASS D: Shoreman, Deckhand, Rodman, Scowman, Cook, Messman, Porter/Janitor.
- CLASS D(a) Oiler.

PREMIUMS: Additional 20% for hazardous material work

FOOTNOTES APPLICABLE TO ABOVE CRAFTS:

- a. PAID HOLIDAYS: New Year's Day, Martin Luther King, Jr.'s Birthday, Memorial Day, Good Friday, Independence Day, Labor Day, Veterans' Day, Thanksgiving Day and Christmas Day
- b. VACATION: Eight percent (8%) of the straight time rate, multiplied by the total hours worked.

INCENTIVE PAY: (Add to Hourly Rate)

- Operator (NCCCO License/Certification) \$0.50 Licensed Tug Operator over 1000 HP (Assigned as Master) (USCG licensed Master of Towing Vessels (MOTV) \$1.00;
- Licensed Boat Operator (Assigned as lead boat captain) USCG licensed boat operator \$0.50;
- Engineer (QMED and Tankerman endorsement or licensed engineer (USCG) \$0.50
- Oiler (QMED and Tankerman endorsement (USCG) \$0.50; All

classifications (Tankerman endorsement only) USCG \$0.25;
Deckhand or Mate (AB with Lifeboatman endorsement (USCG)
\$0.50; All classifications (lifeboatman endorsement only
(USCG) \$0.25; Welder (ABS certification) \$0.50

WELDERS - Receive rate prescribed for craft performing
operation to which welding is incidental.

Unlisted classifications needed for work not included within
the scope of the classifications listed may be added after
award only as provided in the labor standards contract clauses
(29CFR 5.5 (a) (1) (ii)).

In the listing above, the "SU" designation means that rates
listed under the identifier do not reflect collectively
bargained wage and fringe benefit rates. Other designations
indicate unions whose rates have been determined to be
prevailing.

WAGE DETERMINATION APPEALS PROCESS

1.) Has there been an initial decision in the matter? This can
be:

- * an existing published wage determination
- * a survey underlying a wage determination
- * a Wage and Hour Division letter setting forth a position on
a wage determination matter
- * a conformance (additional classification and rate) ruling

On survey related matters, initial contact, including requests
for summaries of surveys, should be with the Wage and Hour
Regional Office for the area in which the survey was conducted
because those Regional Offices have responsibility for the
Davis-Bacon survey program. If the response from this initial
contact is not satisfactory, then the process described in 2.)
and 3.) should be followed.

With regard to any other matter not yet ripe for the formal
process described here, initial contact should be with the
Branch of Construction Wage Determinations. Write to:

Branch of Construction Wage Determinations
Wage and Hour Division
U.S. Department of Labor
200 Constitution Avenue, N.W.
Washington, DC 20210

2.) If the answer to the question in 1.) is yes, then an
interested party (those affected by the action) can request
review and reconsideration from the Wage and Hour Administrator
(See 29 CFR Part 1.8 and 29 CFR Part 7). Write to:

Wage and Hour Administrator
U.S. Department of Labor
200 Constitution Avenue, N.W.
Washington, DC 20210

The request should be accompanied by a full statement of the
interested party's position and by any information (wage
payment data, project description, area practice material,
etc.) that the requestor considers relevant to the issue.

3.) If the decision of the Administrator is not favorable, an
interested party may appeal directly to the Administrative
Review Board (formerly the Wage Appeals Board). Write to:

Administrative Review Board
U.S. Department of Labor
200 Constitution Avenue, N.W.
Washington, DC 20210

4.) All decisions by the Administrative Review Board are final.

=====
END OF GENERAL DECISION

General Decision Number: CT100015 06/17/2011 CT15

Superseded General Decision Number: CT20080015

State: Connecticut

Construction Type: Heavy

County: Fairfield County in Connecticut.

HEAVY CONSTRUCTION PROJECTS

Modification Number	Publication Date
0	03/12/2010
1	04/30/2010
2	05/07/2010
3	06/04/2010
4	07/02/2010
5	07/16/2010
6	07/23/2010
7	07/30/2010
8	10/08/2010
9	11/05/2010
10	04/22/2011
11	06/17/2011

BRCT0001-011 04/01/2011

	Rates	Fringes
BRICKLAYER.....	\$ 32.50	22.51

BRCT0001-012 04/01/2011

	Rates	Fringes
CEMENT MASON/CONCRETE FINISHER...	\$ 32.50	22.51

* CARP0210-005 05/02/2011

	Rates	Fringes
CARPENTER.....	\$ 29.11	20.29

ELEC0003-004 05/06/2010

Darien, Greenwich, New Canaan, Stamford and the portion of Norwalk lying West of Five Mile River

	Rates	Fringes
ELECTRICIAN.....	\$ 47.75	34.84

ELEC0488-006 06/01/2010

Bethel, Bridgeport, Brookfield, Danbury, Easton, Fairfield, Monroe, New Fairfield, Newtown, Redding, Ridgefield, Shelton, Sherman, Stratford, Trumbull

	Rates	Fringes
ELECTRICIAN.....	\$ 34.80	21.05

* ENGI0478-007 05/07/2011

	Rates	Fringes
POWER EQUIPMENT OPERATOR:		
Asphalt Paver.....	\$ 33.01	19.40+a
Asphalt Roller.....	\$ 32.36	19.40+a
Asphalt Spreader.....	\$ 33.01	19.40+a
Backhoe/Excavator 2 cubic yards and over.....	\$ 34.73	19.40+a
Backhoe/Excavator under 2 cubic yards.....	\$ 33.99	19.40+a
Bulldozer (Rough Grade Dozer).....	\$ 32.70	19.40+a
Bulldozer Fine		

Grade(includes slopes, shaping, laser or gps).....	\$ 33.99	19.40+a
Crane handling or erecting structural steel or stone...	\$ 35.05	19.40+a
Cranes (100 ton capacity & over).....	\$ 34.73	19.40+a
Cranes (under 100 ton rated capacity).....	\$ 33.99	19.40+a
Drills with self contained power units; Directional driller.....	\$ 33.01	19.40+a
Earth Roller.....	\$ 29.49	19.40+a
Forklift.....	\$ 31.53	19.40+a
Front End Loader (3 cubic yards up to 7 cubic yards)...	\$ 32.70	19.40+a
Front End Loader (7 cubic yards or over).....	\$ 35.05	19.40+a
Front End Loader (under 3 cubic yards).....	\$ 31.53	19.40+a
Grader/Blade.....	\$ 33.99	19.40+a
Maintenance Engineer/Oiler..	\$ 26.65	19.40+a
Mechanic.....	\$ 31.96	19.40+a
Rubber Tire Backhoe/Excavator.....	\$ 33.99	19.40+a

a. PAID HOLIDAYS: New Year's Day, Good Friday, Memorial Day, Independence Day, Labor Day, Thanksgiving Day and Christmas Day, provided the employee works 3 days during the week in which the holiday falls, if scheduled, and if scheduled, the working day before and the working day after the holiday.

- b. Crane with boom, including jib, 150 feet - \$1.50 extra .
- Crane with boom, including jib, 200 feet- \$2.50 extra.
- Crane with boom, including jib, 250 feet - \$5.00 extra.
- Crane with boom, including jib, 300 feet - \$7.00 extra.
- Crane with boom, including jib, 400 feet - \$10.00 extra.

IRON0015-005 06/28/2010

	Rates	Fringes
IRONWORKER, REINFORCING.....	\$ 33.00	26.58+a

a. PAID HOLIDAY: Labor Day provided employee has been on the payroll for the 5 consecutive work days prior to Labor Day.

LABO0056-005 04/03/2011

	Rates	Fringes
LABORERS		
GROUP 1.....	\$ 25.75	15.60
GROUP 2.....	\$ 26.00	15.60
GROUP 3.....	\$ 26.25	15.60
GROUP 4.....	\$ 26.75	15.60
GROUP 5.....	\$ 27.50	15.60
GROUP 6.....	\$ 27.75	15.60
GROUP 7.....	\$ 16.00	15.60

LABORERS CLASSIFICATIONS

GROUP 1: Laborers (Unskilled), acetylene burner, concrete specialist

GROUP 2: Chain saw operators, fence and guard rail erectors, pneumatic tool operators and powdermen.

GROUP 3: Pipelayers, Jackhammer/Pavement breaker (handheld), mason tenders/catch basin builders, asphalt rakers, air track operators, block paver and curb setter

GROUP 4: Asbestos/lead removal

GROUP 5: Blasters

GROUP 6: Toxic waste remover

GROUP 7: Traffic control signalman

	Rates	Fringes
PAINTER		
Brush and Roller.....	\$ 28.47	15.40
Spray Only.....	\$ 31.47	15.40
Steel Only.....	\$ 30.47	15.40

SUCT2002-008 12/16/2008

	Rates	Fringes
IRONWORKER, STRUCTURAL.....	\$ 28.62	10.84

* TEAM0064-006 04/03/2011

	Rates	Fringes
TRUCK DRIVER: 4 Axle Truck.....	\$ 28.08	15.71+a

WELDERS - Receive rate prescribed for craft performing operation to which welding is incidental.

=====

Unlisted classifications needed for work not included within the scope of the classifications listed may be added after award only as provided in the labor standards contract clauses (29 CFR 5.5(a)(1)(ii)).

--

In the listing above, the "SU" designation means that rates listed under the identifier do not reflect collectively bargained wage and fringe benefit rates. Other designations indicate unions whose rates have been determined to be prevailing.

--

WAGE DETERMINATION APPEALS PROCESS

1.) Has there been an initial decision in the matter? This can be:

- * an existing published wage determination
- * a survey underlying a wage determination
- * a Wage and Hour Division letter setting forth a position on a wage determination matter
- * a conformance (additional classification and rate) ruling

On survey related matters, initial contact, including requests for summaries of surveys, should be with the Wage and Hour Regional Office for the area in which the survey was conducted because those Regional Offices have responsibility for the Davis-Bacon survey program. If the response from this initial contact is not satisfactory, then the process described in 2.) and 3.) should be followed.

With regard to any other matter not yet ripe for the formal process described here, initial contact should be with the Branch of Construction Wage Determinations. Write to:

Branch of Construction Wage Determinations
Wage and Hour Division
U.S. Department of Labor

200 Constitution Avenue, N.W.
Washington, DC 20210

2.) If the answer to the question in 1.) is yes, then an interested party (those affected by the action) can request review and reconsideration from the Wage and Hour Administrator (See 29 CFR Part 1.8 and 29 CFR Part 7).
Write to:

Wage and Hour Administrator
U.S. Department of Labor
200 Constitution Avenue, N.W.
Washington, DC 20210

The request should be accompanied by a full statement of the interested party's position and by any information (wage payment data, project description, area practice material, etc.) that the requestor considers relevant to the issue.

3.) If the decision of the Administrator is not favorable, an interested party may appeal directly to the Administrative Review Board (formerly the Wage Appeals Board). Write to:

Administrative Review Board
U.S. Department of Labor
200 Constitution Avenue, N.W.
Washington, DC 20210

4.) All decisions by the Administrative Review Board are final.

END OF GENERAL DECISION

General Decision Number: CT100016 07/08/2011 CT16

Superseded General Decision Number: CT20080016

State: Connecticut

Construction Type: Heavy

County: Hartford County in Connecticut.

HEAVY CONSTRUCTION PROJECTS

Modification Number	Publication Date
0	03/12/2010
1	04/30/2010
2	05/07/2010
3	06/04/2010
4	07/02/2010
5	07/23/2010
6	07/30/2010
7	10/08/2010
8	11/05/2010
9	04/22/2011
10	06/03/2011
11	06/17/2011
12	07/08/2011

BRCT0001-012 04/01/2011

	Rates	Fringes
CEMENT MASON/CONCRETE FINISHER...	\$ 32.50	22.51

CARP0024-014 05/02/2011

Berlin, Bristol, Burlington, Canton, Marlborough, New Britain, Newington, Plainville and Southington

	Rates	Fringes
CARPENTER, Includes Form Work...	\$ 29.11	20.29

CARP0043-005 05/02/2011

Avon, Bloomfield, East Branby, East Hartford, East Windsor, Enfield, Farmington, Glastonbury, Granby, Hartford, Hartland, Manchester, Rocky Hill, Simsbury, South Windsor, Suffield, West Hartford, Wethersfield, Windsor, Windsor Locks

	Rates	Fringes
CARPENTER, Includes Form Work...	\$ 29.11	20.29

* ELEC0035-006 06/01/2011

Entire County excluding Berlin, Bristol, Hartland, New Britain, Newington, Plainville and Southington Townships

	Rates	Fringes
ELECTRICIAN.....	\$ 36.40	21.31

ELEC0090-005 06/01/2011

Berlin, Bristol, New Britain, Newington, Plainville, Southington Townships

	Rates	Fringes
ELECTRICIAN.....	\$ 35.70	21.52

ELEC0488-005 06/01/2010

Hartland Township

Rates	Fringes
-------	---------

ELECTRICIAN.....\$ 34.80 21.05

 ENGI0478-010 05/07/2011

	Rates	Fringes
POWER EQUIPMENT OPERATOR:		
Asphalt Paver.....	\$ 33.01	19.40+a
Asphalt Roller.....	\$ 32.36	19.40+a
Asphalt Spreader.....	\$ 33.01	19.40+a
Bulldozer (Rough Grade Dozer).....	\$ 32.70	19.40+a
Bulldozer Fine Grade(includes slopes, shaping, laser or gps).....	\$ 33.99	19.40+a
Crane handling or erecting structural steel or stone...\$	35.05	19.40+a
Cranes (100 ton capacity & over).....	\$ 34.73	19.40+a
Cranes (under 100 ton rated capacity).....	\$ 33.99	19.40+a
Drills with self contained power units; Directional driller.....	\$ 33.01	19.40+a
Earth Roller.....	\$ 29.49	19.40+a
Excavator/Backhoe 2 cubic yards and over.....	\$ 34.73	19.40+a
Excavator/Backhoe under 2 cubic yards.....	\$ 33.99	19.40+a
Forklift.....	\$ 31.53	19.40+a
Front End Loader (3 cubic yards up to 7 cubic yards)..\$	32.70	19.40+a
Front End Loader (7 cubic yards or over).....	\$ 35.05	19.40+a
Front End Loader (under 3 cubic yards).....	\$ 31.53	19.40+a
Grader/Blade.....	\$ 33.99	19.40+a
Maintenance Engineer/Oiler..\$	26.65	19.40+a
Mechanic.....	\$ 31.96	19.40+a

a. PAID HOLIDAYS: New Year's Day, Good Friday, Memorial Day, Independence Day, Labor Day, Thanksgiving Day and Christmas Day, provided the employee works 3 days during the week in which the holiday falls, if scheduled, and if scheduled, the working day before and the working day after the holiday.

- b. Crane with boom, including jib, 150 feet - \$1.50 extra .
 Crane with boom, including jib, 200 feet- \$2.50 extra.
 Crane with boom, including jib, 250 feet - \$5.00 extra.
 Crane with boom, including jib, 300 feet - \$7.00 extra.
 Crane with boom, including jib, 400 feet - \$10.00 extra.

 IRON0015-007 06/28/2010

	Rates	Fringes
IRONWORKER, STRUCTURAL.....	\$ 33.00	26.58+a

a. PAID HOLIDAY: Labor Day provided employee has been on the payroll for the 5 consecutive work days prior to Labor Day.

 LABO0056-006 04/03/2011

	Rates	Fringes
LABORERS		
GROUP 1.....	\$ 25.75	15.60
GROUP 2.....	\$ 26.00	15.60
GROUP 3.....	\$ 26.25	15.60
GROUP 4.....	\$ 26.75	15.60
GROUP 5.....	\$ 27.50	15.60
GROUP 6.....	\$ 27.75	15.60
GROUP 7.....	\$ 16.00	15.60

LABORERS CLASSIFICATIONS

GROUP 1: Laborers (Unskilled), acetylene burner, concrete specialist

GROUP 2: Chain saw operators, fence and guard rail erectors, pneumatic tool operators and powdermen.

GROUP 3: Pipelayers, Jackhammer/Pavement breaker (handheld), mason tenders/catch basin builders, asphalt rakers, air track operators, block paver and curb setter

GROUP 4: Asbestos/lead removal

GROUP 5: Blasters

GROUP 6: Toxic waste remover

GROUP 7: Traffic control signalman

PAIN0011-013 06/01/2010

	Rates	Fringes
PAINTER		
Brush and Roller.....	\$ 28.47	15.40
Spray Only.....	\$ 31.47	15.40
Steel Only.....	\$ 30.47	15.40

SUCT2002-009 12/16/2008

	Rates	Fringes
IRONWORKER, REINFORCING.....	\$ 27.13	13.57
LABORER: Common or General.....	\$ 21.03	5.30
OPERATOR: Excavator.....	\$ 27.77	7.60
TRUCK DRIVER: 3 Axle & Semi - Truck.....	\$ 19.93	7.39

TEAM0064-006 04/03/2011

	Rates	Fringes
TRUCK DRIVER: 4 Axle Truck.....	\$ 28.08	15.71+a

WELDERS - Receive rate prescribed for craft performing operation to which welding is incidental.

=====
Unlisted classifications needed for work not included within the scope of the classifications listed may be added after award only as provided in the labor standards contract clauses (29 CFR 5.5(a)(1)(ii)).

--
In the listing above, the "SU" designation means that rates listed under the identifier do not reflect collectively bargained wage and fringe benefit rates. Other designations indicate unions whose rates have been determined to be prevailing.

--

WAGE DETERMINATION APPEALS PROCESS

1.) Has there been an initial decision in the matter? This can be:

- * an existing published wage determination
- * a survey underlying a wage determination
- * a Wage and Hour Division letter setting forth a position on a wage determination matter

* a conformance (additional classification and rate) ruling

On survey related matters, initial contact, including requests for summaries of surveys, should be with the Wage and Hour Regional Office for the area in which the survey was conducted because those Regional Offices have responsibility for the Davis-Bacon survey program. If the response from this initial contact is not satisfactory, then the process described in 2.) and 3.) should be followed.

With regard to any other matter not yet ripe for the formal process described here, initial contact should be with the Branch of Construction Wage Determinations. Write to:

Branch of Construction Wage Determinations
Wage and Hour Division
U.S. Department of Labor
200 Constitution Avenue, N.W.
Washington, DC 20210

2.) If the answer to the question in 1.) is yes, then an interested party (those affected by the action) can request review and reconsideration from the Wage and Hour Administrator (See 29 CFR Part 1.8 and 29 CFR Part 7).
Write to:

Wage and Hour Administrator
U.S. Department of Labor
200 Constitution Avenue, N.W.
Washington, DC 20210

The request should be accompanied by a full statement of the interested party's position and by any information (wage payment data, project description, area practice material, etc.) that the requestor considers relevant to the issue.

3.) If the decision of the Administrator is not favorable, an interested party may appeal directly to the Administrative Review Board (formerly the Wage Appeals Board). Write to:

Administrative Review Board
U.S. Department of Labor
200 Constitution Avenue, N.W.
Washington, DC 20210

4.) All decisions by the Administrative Review Board are final.

END OF GENERAL DECISION

General Decision Number: CT100017 07/08/2011 CT17

Superseded General Decision Number: CT20080017

State: Connecticut

Construction Type: Heavy

Counties: Middlesex and Tolland Counties in Connecticut.

HEAVY CONSTRUCTION PROJECTS

Modification Number	Publication Date
0	03/12/2010
1	05/07/2010
2	06/04/2010
3	07/02/2010
4	07/23/2010
5	07/30/2010
6	11/05/2010
7	04/22/2011
8	06/03/2011
9	06/17/2011
10	07/08/2011

CARP0024-016 05/02/2011

MIDDLESEX COUNTY

TOLLAND COUNTY

Andover, Columbia, Coventry, Hebron, Mansfield, Union, Willington

	Rates	Fringes
CARPENTER, Includes Form Work....	\$ 29.11	20.29

CARP0043-006 05/02/2011

TOLLAND COUNTY

Bolton, Ellington, Somers, Tolland, Vernon

	Rates	Fringes
CARPENTER, Includes Form Work....	\$ 29.11	20.29

* ELEC0035-004 06/01/2011

Cromwell, Middlefield, Middleton and Portland

	Rates	Fringes
ELECTRICIAN.....	\$ 36.40	21.31

ELEC0090-006 06/01/2011

Chester, Clinton, Deep River, Durham, East Haddam, East Hampton, Essex, Haddam, Killingsworth, Old Saybrook, Westbrook

	Rates	Fringes
ELECTRICIAN.....	\$ 35.70	21.52

ENGI0478-007 05/07/2011

	Rates	Fringes
POWER EQUIPMENT OPERATOR:		
Asphalt Paver.....	\$ 33.01	19.40+a
Asphalt Roller.....	\$ 32.36	19.40+a
Asphalt Spreader.....	\$ 33.01	19.40+a
Backhoe/Excavator 2 cubic yards and over.....	\$ 34.73	19.40+a
Backhoe/Excavator under 2 cubic yards.....	\$ 33.99	19.40+a
Bulldozer (Rough Grade Dozer).....	\$ 32.70	19.40+a
Bulldozer Fine		

Grade(includes slopes, shaping, laser or gps).....	\$ 33.99	19.40+a
Crane handling or erecting structural steel or stone...	\$ 35.05	19.40+a
Cranes (100 ton capacity & over).....	\$ 34.73	19.40+a
Cranes (under 100 ton rated capacity).....	\$ 33.99	19.40+a
Drills with self contained power units; Directional driller.....	\$ 33.01	19.40+a
Earth Roller.....	\$ 29.49	19.40+a
Forklift.....	\$ 31.53	19.40+a
Front End Loader (3 cubic yards up to 7 cubic yards)..	\$ 32.70	19.40+a
Front End Loader (7 cubic yards or over).....	\$ 35.05	19.40+a
Front End Loader (under 3 cubic yards).....	\$ 31.53	19.40+a
Grader/Blade.....	\$ 33.99	19.40+a
Maintenance Engineer/Oiler..	\$ 26.65	19.40+a
Mechanic.....	\$ 31.96	19.40+a
Rubber Tire Backhoe/Excavator.....	\$ 33.99	19.40+a

a. PAID HOLIDAYS: New Year's Day, Good Friday, Memorial Day, Independence Day, Labor Day, Thanksgiving Day and Christmas Day, provided the employee works 3 days during the week in which the holiday falls, if scheduled, and if scheduled, the working day before and the working day after the holiday.

- b. Crane with boom, including jib, 150 feet - \$1.50 extra .
- Crane with boom, including jib, 200 feet- \$2.50 extra.
- Crane with boom, including jib, 250 feet - \$5.00 extra.
- Crane with boom, including jib, 300 feet - \$7.00 extra.
- Crane with boom, including jib, 400 feet - \$10.00 extra.

IRON0015-008 06/28/2010

	Rates	Fringes
IRONWORKER, REINFORCING AND STRUCTURAL.....	\$ 33.00	26.58+a

a. PAID HOLIDAY: Labor Day provided employee has been on the payroll for the 5 consecutive work days prior to Labor Day.

LABO0056-007 04/03/2011

	Rates	Fringes
LABORERS		
GROUP 1.....	\$ 25.75	15.60
GROUP 2.....	\$ 26.00	15.60
GROUP 3.....	\$ 26.25	15.60
GROUP 4.....	\$ 26.75	15.60
GROUP 5.....	\$ 27.50	15.60
GROUP 6.....	\$ 27.75	15.60
GROUP 7.....	\$ 16.00	15.60

LABORERS CLASSIFICATIONS

GROUP 1: Laborers (Unskilled), acetylene burner, concrete specialist

GROUP 2: Chain saw operators, fence and guard rail erectors, pneumatic tool operators and powdermen.

GROUP 3: Pipelayers, Jackhammer/Pavement breaker (handheld), mason tenders/catch basin builders, asphalt rakers, air track operators, block paver and curb setter

GROUP 4: Asbestos/lead removal

GROUP 5: Blasters

GROUP 6: Toxic waste remover

GROUP 7: Traffic control signalman

PAIN0011-013 06/01/2010

	Rates	Fringes
PAINTER		
Brush and Roller.....	\$ 28.47	15.40
Spray Only.....	\$ 31.47	15.40
Steel Only.....	\$ 30.47	15.40

SUCT2002-010 12/16/2008

	Rates	Fringes
CEMENT MASON/CONCRETE FINISHER...	\$ 25.52	8.49
TRUCK DRIVER: 3 Axle & Semi		
- Truck.....	\$ 19.93	7.39

TEAM0064-006 04/03/2011

	Rates	Fringes
TRUCK DRIVER: 4 Axle Truck.....	\$ 28.08	15.71+a

WELDERS - Receive rate prescribed for craft performing operation to which welding is incidental.

=====
Unlisted classifications needed for work not included within the scope of the classifications listed may be added after award only as provided in the labor standards contract clauses (29 CFR 5.5(a)(1)(ii)).

--
In the listing above, the "SU" designation means that rates listed under the identifier do not reflect collectively bargained wage and fringe benefit rates. Other designations indicate unions whose rates have been determined to be prevailing.

--
WAGE DETERMINATION APPEALS PROCESS

1.) Has there been an initial decision in the matter? This can be:

- * an existing published wage determination
- * a survey underlying a wage determination
- * a Wage and Hour Division letter setting forth a position on a wage determination matter
- * a conformance (additional classification and rate) ruling

On survey related matters, initial contact, including requests for summaries of surveys, should be with the Wage and Hour Regional Office for the area in which the survey was conducted because those Regional Offices have responsibility for the Davis-Bacon survey program. If the response from this initial contact is not satisfactory, then the process described in 2.) and 3.) should be followed.

With regard to any other matter not yet ripe for the formal process described here, initial contact should be with the Branch of Construction Wage Determinations. Write to:

Branch of Construction Wage Determinations
Wage and Hour Division
U.S. Department of Labor
200 Constitution Avenue, N.W.
Washington, DC 20210

2.) If the answer to the question in 1.) is yes, then an interested party (those affected by the action) can request review and reconsideration from the Wage and Hour Administrator (See 29 CFR Part 1.8 and 29 CFR Part 7).

Write to:

Wage and Hour Administrator
U.S. Department of Labor
200 Constitution Avenue, N.W.
Washington, DC 20210

The request should be accompanied by a full statement of the interested party's position and by any information (wage payment data, project description, area practice material, etc.) that the requestor considers relevant to the issue.

3.) If the decision of the Administrator is not favorable, an interested party may appeal directly to the Administrative Review Board (formerly the Wage Appeals Board). Write to:

Administrative Review Board
U.S. Department of Labor
200 Constitution Avenue, N.W.
Washington, DC 20210

4.) All decisions by the Administrative Review Board are final.

END OF GENERAL DECISION

General Decision Number: CT100019 07/08/2011 CT19

Superseded General Decision Number: CT20080019

State: Connecticut

Construction Type: Heavy

County: New London County in Connecticut.

HEAVY CONSTRUCTION PROJECTS

Modification Number	Publication Date
0	03/12/2010
1	05/07/2010
2	06/04/2010
3	07/02/2010
4	07/23/2010
5	07/30/2010
6	11/05/2010
7	04/22/2011
8	06/17/2011
9	07/08/2011

CARP0024-007 05/02/2011

	Rates	Fringes
CARPENTER, Includes Form Work....	\$ 29.11	20.29

* ELEC0035-011 06/01/2011

Bozrah, Colchester, Franklin, Griswold, Lebanon, Ledyard, Lisbon, Montville, North Stonington, Norwich, Preston, Salem, Sprague, Stonington and Voluntown

	Rates	Fringes
ELECTRICIAN.....	\$ 36.40	21.31

ELEC0090-003 06/01/2010

East Lyme, Groton, New London, Old Lyme, Waterford, plus the part of Ledyard wherein the property of the Submarine Base is located

	Rates	Fringes
ELECTRICIAN.....	\$ 35.20	20.51

ENGI0478-008 05/07/2011

	Rates	Fringes
POWER EQUIPMENT OPERATOR:		
Asphalt Paver.....	\$ 33.01	19.40+a
Asphalt Roller.....	\$ 32.36	19.40+a
Asphalt Spreader.....	\$ 33.01	19.40+a
Backhoe/Excavator 2 cubic yards and over.....	\$ 34.73	19.40+a
Backhoe/Excavator under 2 cubic yards.....	\$ 33.99	19.40+a
Bulldozer (Rough Grade Dozer).....	\$ 32.70	19.40+a
Bulldozer Fine Grade(includes slopes, shaping, laser or gps).....	\$ 33.99	19.40+a
Crane handling or erecting structural steel or stone...	\$ 35.05	19.40+a
Cranes (100 ton capacity & over).....	\$ 34.73	19.40+a
Cranes (under 100 ton rated capacity).....	\$ 33.99	19.40+a
Drills with self contained power units; Directional driller.....	\$ 33.01	19.40+a
Earth Roller.....	\$ 29.49	19.40+a
Forklift.....	\$ 31.53	19.40+a

Front End Loader (3 cubic yards up to 7 cubic yards)..	\$ 32.70	19.40+a
Front End Loader (7 cubic yards or over).....	\$ 35.05	19.40+a
Front End Loader (under 3 cubic yards).....	\$ 31.53	19.40+a
Grader/Blade.....	\$ 33.99	19.40+a
Maintenance Engineer/Oiler..	\$ 26.65	19.40+a
Mechanic.....	\$ 31.96	19.40+a
Rubber Tire		
Backhoe/Excavator.....	\$ 33.99	19.40+a

a. PAID HOLIDAYS: New Year's Day, Good Friday, Memorial Day, Independence Day, Labor Day, Thanksgiving Day and Christmas Day, provided the employee works 3 days during the week in which the holiday falls, if scheduled, and if scheduled, the working day before and the working day after the holiday.

- b. Crane with boom, including jib, 150 feet - \$1.50 extra .
- Crane with boom, including jib, 200 feet- \$2.50 extra .
- Crane with boom, including jib, 250 feet - \$5.00 extra.
- Crane with boom, including jib, 300 feet - \$7.00 extra.
- Crane with boom, including jib, 400 feet - \$10.00 extra.

IRON0015-008 06/28/2010

	Rates	Fringes
IRONWORKER, REINFORCING AND STRUCTURAL.....	\$ 33.00	26.58+a

a. PAID HOLIDAY: Labor Day provided employee has been on the payroll for the 5 consecutive work days prior to Labor Day.

LABO0056-007 04/03/2011

	Rates	Fringes
LABORERS		
GROUP 1.....	\$ 25.75	15.60
GROUP 2.....	\$ 26.00	15.60
GROUP 3.....	\$ 26.25	15.60
GROUP 4.....	\$ 26.75	15.60
GROUP 5.....	\$ 27.50	15.60
GROUP 6.....	\$ 27.75	15.60
GROUP 7.....	\$ 16.00	15.60

LABORERS CLASSIFICATIONS

GROUP 1: Laborers (Unskilled), acetylene burner, concrete specialist

GROUP 2: Chain saw operators, fence and guard rail erectors, pneumatic tool operators and powdermen.

GROUP 3: Pipelayers, Jackhammer/Pavement breaker (handheld), mason tenders/catch basin builders, asphalt rakers, air track operators, block paver and curb setter

GROUP 4: Asbestos/lead removal

GROUP 5: Blasters

GROUP 6: Toxic waste remover

GROUP 7: Traffic control signalman

PAIN0011-013 06/01/2010

	Rates	Fringes
PAINTER		
Brush and Roller.....	\$ 28.47	15.40
Spray Only.....	\$ 31.47	15.40
Steel Only.....	\$ 30.47	15.40

SUCT2002-012 12/16/2008

Rates	Fringes
-------	---------

CEMENT MASON/CONCRETE FINISHER...\$ 25.52 8.49
TRUCK DRIVER: 3 Axle & Semi
- Truck.....\$ 19.93 7.01

TEAM0064-006 04/03/2011

Rates Fringes
TRUCK DRIVER: 4 Axle Truck.....\$ 28.08 15.71+a

WELDERS - Receive rate prescribed for craft performing operation to which welding is incidental.

=====
Unlisted classifications needed for work not included within the scope of the classifications listed may be added after award only as provided in the labor standards contract clauses (29 CFR 5.5(a)(1)(ii)).

--

In the listing above, the "SU" designation means that rates listed under the identifier do not reflect collectively bargained wage and fringe benefit rates. Other designations indicate unions whose rates have been determined to be prevailing.

--

WAGE DETERMINATION APPEALS PROCESS

1.) Has there been an initial decision in the matter? This can be:

- * an existing published wage determination
- * a survey underlying a wage determination
- * a Wage and Hour Division letter setting forth a position on a wage determination matter
- * a conformance (additional classification and rate) ruling

On survey related matters, initial contact, including requests for summaries of surveys, should be with the Wage and Hour Regional Office for the area in which the survey was conducted because those Regional Offices have responsibility for the Davis-Bacon survey program. If the response from this initial contact is not satisfactory, then the process described in 2.) and 3.) should be followed.

With regard to any other matter not yet ripe for the formal process described here, initial contact should be with the Branch of Construction Wage Determinations. Write to:

Branch of Construction Wage Determinations
Wage and Hour Division
U.S. Department of Labor
200 Constitution Avenue, N.W.
Washington, DC 20210

2.) If the answer to the question in 1.) is yes, then an interested party (those affected by the action) can request review and reconsideration from the Wage and Hour Administrator (See 29 CFR Part 1.8 and 29 CFR Part 7).

Write to:

Wage and Hour Administrator
U.S. Department of Labor
200 Constitution Avenue, N.W.
Washington, DC 20210

The request should be accompanied by a full statement of the interested party's position and by any information (wage payment data, project description, area practice material, etc.) that the requestor considers relevant to the issue.

3.) If the decision of the Administrator is not favorable, an interested party may appeal directly to the Administrative Review Board (formerly the Wage Appeals Board). Write to:

Administrative Review Board
U.S. Department of Labor
200 Constitution Avenue, N.W.
Washington, DC 20210

4.) All decisions by the Administrative Review Board are final.

END OF GENERAL DECISION

General Decision Number: CT100029 07/08/2011 CT29

Superseded General Decision Number: CT20080029

State: Connecticut

Construction Type: Heavy

Counties: Litchfield and Windham Counties in Connecticut.

HEAVY CONSTRUCTION PROJECTS

Modification Number	Publication Date
0	03/12/2010
1	04/23/2010
2	04/30/2010
3	05/07/2010
4	06/04/2010
5	07/02/2010
6	07/23/2010
7	07/30/2010
8	08/20/2010
9	09/03/2010
10	10/08/2010
11	11/05/2010
12	04/22/2011
13	05/13/2011
14	06/03/2011
15	06/10/2011
16	06/17/2011
17	07/08/2011

BRCT0001-015 04/01/2011

	Rates	Fringes
BRICKLAYER		
BRICKLAYERS, CEMENT		
MASONS, CEMENT FINISHERS,		
STONE MASONS.....	\$ 32.50	22.51

CARP0024-011 05/02/2011

	Rates	Fringes
CARPENTER		
Carpenters, Piledrivers.....	\$ 29.11	20.29
Diver Tenders.....	\$ 29.11	20.29
Divers.....	\$ 37.57	20.29
Millwrights.....	\$ 30.01	20.18

* ELEC0035-008 06/01/2011

WINDHAM COUNTY

	Rates	Fringes
ELECTRICIAN.....	\$ 36.40	21.31

ELEC0042-001 08/30/2010

	Rates	Fringes
Line Construction: (Line Construction)		
Driver Groundmen.....	\$ 30.92	6.5%+9.70
Groundmen.....	\$ 22.67	6.5%+6.20
Heavy Equipment Operators...	\$ 37.10	6.5%+10.70
Linemen, Cable Splicers,		
Dynamite Men.....	\$ 41.22	6.5%+12.20
Material Men, Tractor		
Trailer Drivers, Equipment		
Operators.....	\$ 35.04	6.5%+10.45
Line Construction: (Railroad Construction and Maintenance)		
Driver Groundmen.....	\$ 33.27	3%+13.70
Heavy Equipment Operators...	\$ 39.92	3%+13.70
Linemen, Cable Splicers,		
Dynamite Men.....	\$ 44.36	3%+13.70

Material Men, Tractor
 Trailer Drivers,
 Equipment Operators.....\$ 37.71 3%+13.70

 ELEC0090-008 06/01/2011

LITCHFIELD COUNTY
 Plymouth Township

	Rates	Fringes
ELECTRICIAN.....	\$ 35.70	21.52

 ELEC0488-011 06/01/2010

LITCHFIELD COUNTY (Excluding Plymouth Township)

	Rates	Fringes
ELECTRICIAN.....	\$ 34.80	21.05

 ENGI0478-001 05/07/2011

	Rates	Fringes
Power equipment operators:		
GROUP 1.....	\$ 35.05	19.40
GROUP 2.....	\$ 34.73	19.40
GROUP 3.....	\$ 33.99	19.40
GROUP 4.....	\$ 33.60	19.40
GROUP 5.....	\$ 33.01	19.40
GROUP 6.....	\$ 32.70	19.40
GROUP 7.....	\$ 32.36	19.40
GROUP 8.....	\$ 31.96	19.40
GROUP 9.....	\$ 31.53	19.40
GROUP 10.....	\$ 29.49	19.40
GROUP 11.....	\$ 29.49	19.40
GROUP 12.....	\$ 29.43	19.40
GROUP 13.....	\$ 30.96	19.40
GROUP 14.....	\$ 28.85	19.40
GROUP 15.....	\$ 28.54	19.40
GROUP 16.....	\$ 27.71	19.40
GROUP 17.....	\$ 27.30	19.40
GROUP 18.....	\$ 26.65	19.40

Hazardous waste premium \$3.00 per hour over classified rate.

Crane with boom, including jib, 150 feet - \$1.50 extra.
 Crane with boom, including jib, 200 feet - \$2.50 extra.
 Crane with boom, including jib, 250 feet - \$5.00 extra.
 Crane with boom, including jib, 300 feet - \$7.00 extra.
 Crane with boom, including jib, 400 feet - \$10.00 extra

a. PAID HOLIDAYS: New Year's Day, Good Friday, Memorial Day, Independence Day, Labor Day, Thanksgiving Day and Christmas Day, provided the employee works 3 days during the week in which the holiday falls, if scheduled, and if scheduled, the working day before and the working day after the holiday.

POWER EQUIPMENT OPERATORS CLASSIFICATIONS

GROUP 1: Crane handling or erecting structural steel or stone, hoisting engineer (2 drums or over), front end loader (7 cubic yards or over), work boat 26 ft. and over.

GROUP 2: Cranes (100 ton capacity & over), Excavator over 2 cubic yards, piledriver (\$3.00 premium when operator controls hammer).

GROUP 3: Excavator, cranes (under 100 ton rated capacity), gradall, master mechanic, hoisting engineer (all types of equipment where a drum and cable are used to hoist or drag material regardless of motive power or operation) Rubber Tire Excavator (drott 1085 or similar); Grader Operator; Bulldozer Fine Grade (slopes, shaping, laser or GPS, etc.)

GROUP 4: Trenching machines, lighter derrick, concrete finishing machine, CMI machine or similar, Koehring Loader (skoooper).

GROUP 5: Specialty railroad equipment, asphalt spreader, asphalt reclaiming machine, line grider, concrete pumps, drills with self contained power units, boring machine, post hole digger, auger, pounder, well digger, milling machine (over 24' mandrel), side boom, combination hoe and loader, directional driller.

GROUP 6: Front end loader (3 cu. yds. up to 7 cu. yards), bulldozer (Rough grade dozer) .

GROUP 7: Asphalt roller, concrete saws and cutters (ride on types), Vermeer concrete cutter, stump grinder, scraper, snooper, skidder, milling machine (24" and under Mandrel).

GROUP 8: Mechanic, grease truck operator, hydoblaster, barrier mover, power stone spreader, welder, work boat under 26 ft. transfer machine.

GROUP 9: Front end loader (under 3 cubic yards), skid steer loader (regardless of attachments), bobcat or similar, forklift, power chipper, landscape equipment (including hydroseeder).

GROUP 10: Vibratory hammer, ice machine, diesel & air, hammer, etc.

GROUP 11: Conveyor, earth roller, power pavement breaker (whiphammer), robot demolition equipment.

GROUP 12: Wellpoint operator.

GROUP 13: Portable asphalt plant operator, portable concrete plant operator, portable crusher plant operator.

GROUP 14: Compressor battery operator.

GROUP 15: Power Safety boat, Vacuum truck, Zim mixer, Sweeper; (Minimum for any job requiring a CDL license) .

GROUP 16: Elevator operator, tow motor operator (solid tire no rough terrain).

GROUP 17: Generator operator, compressor operator, pump operator, welding machine operator; Heater operator.

GROUP 18: Maintenance engineer.

IRON0015-001 06/28/2010

	Rates	Fringes
Ironworkers: (Ornamental, Reinforcing, Structural and Precast Concrete Erection).....	\$ 33.00	26.58+a

PAID HOLIDAY: Labor Day provided employee has been on the payroll for the 5 consecutive work days prior to Labor Day.

LABO0056-004 04/03/2011

	Rates	Fringes
Laborers: (TUNNEL CONSTRUCTION)		
CLEANING, CONCRETE AND CAULKING TUNNEL:		
Concrete Workers, Form Movers and Strippers.....	\$ 29.44	15.60
Form Erectors.....	\$ 29.74	15.60
ROCK SHAFT, CONCRETE, LINING OF SAME AND TUNNEL IN FREE AIR:		
Brakemen, Trackmen, Tunnel Laborers, Shaft Laborers.....	\$ 29.44	15.60
Laborers Topside, Cage Tenders, Bellman.....	\$ 29.33	15.60
Miners.....	\$ 30.32	15.60
SHIELD DRIVE AND LINER PLATE TUNNELS IN FREE AIR:		
Brakemen and Trackmen.....	\$ 29.44	15.60

Miners, Motormen, Mucking Machine Operators, Nozzlemen, Grout Men, Shaft and Tunnel, Steel and Rodmen, Shield and Erector, Arm Operator, Cable Tenders.....	\$ 30.32	15.60
TUNNELS, CAISSON AND CYLINDER WORK IN COMPRESSED AIR:		
Blaster.....	\$ 35.213	15.60
Brakemen, Trackmen, Groutman, Laborers, Outside Lock Tender, Gauge Tenders.....	\$ 35.036	15.60
Change House Attendants, Powder Watchmen, Top on Iron Bolts.....	\$ 33.268	15.60
Mucking Machine Operator...	\$ 35.745	15.60

a. PAID HOLIDAYS: On tunnel work only: New Year's Day,
Memorial Day, Independence Day, Labor Day, Thanksgiving Day
and Christmas Day.

No employee shall be eligible for holiday pay when he fails,
without cause, to work the regular work day preceding the
holiday or the regular work day following the holiday.

LABO0056-013 04/03/2011

	Rates	Fringes
LABORER (HEAVY CONSTRUCTION)		
GROUP 1.....	\$ 25.75	15.60
GROUP 2.....	\$ 26.00	15.60
GROUP 3.....	\$ 26.25	15.60
GROUP 4.....	\$ 26.75	15.60
GROUP 5.....	\$ 27.50	15.60
GROUP 6.....	\$ 27.75	15.60
GROUP 7.....	\$ 16.00	15.60

LABORERS CLASSIFICATIONS

GROUP 1: Laborers (Unskilled), acetylene burner, concrete
specialist

GROUP 2: Chain saw operators, fence and guard rail erectors,
pneumatic tool operators and powdermen.

GROUP 3: Pipelayers, Jackhammer/Pavement breaker (handheld),
mason
tenders/catch basin builders, asphalt rakers, air track
operators, block paver and curb setter

GROUP 4: Asbestos/lead removal

GROUP 5: Blasters

GROUP 6: Toxic waste remover

GROUP 7: Traffic control signalman

PAIN0011-003 06/01/2011

	Rates	Fringes
Painters: (BRIDGE CONSTRUCTION)		
Brush, Roller, Blasting (Sand, Water, etc.) Spray...	\$ 41.35	16.35

PAIN0011-018 06/01/2010

	Rates	Fringes
PAINTER		
Blast and Spray.....	\$ 31.47	15.40
Brush and Roll.....	\$ 28.47	15.40
Tanks, Towers, Swing.....	\$ 30.47	15.40

PLUM0777-002 06/01/2011

	Rates	Fringes
PLUMBER/PIPEFITTER.....	\$ 38.67	24.46

TEAM0064-001 04/03/2011

	Rates	Fringes
Truck drivers:		
2 Axle Ready Mix.....	\$ 27.98	15.71+a
2 Axle.....	\$ 27.88	15.71+a
3 Axle Ready Mix.....	\$ 28.03	15.71+a
3 Axle.....	\$ 27.98	15.71+a
4 Axle Ready Mix.....	\$ 28.13	15.71+a
4 Axle.....	\$ 28.08	15.71+a
Heavy Duty Trailer 40 tons and over.....	\$ 28.33	15.71+a
Heavy Duty Trailer up to 40 tons.....	\$ 28.08	15.71+a
Specialized (Earth moving equipment other than conventional type on-the- road trucks and semi- trailers, including Euclids).....	\$ 28.13	15.71+a

Hazardous waste removal work receives additional \$1.25 per hour.

a. PAID HOLIDAYS: New Year's Day, Memorial Day, Independence Day, Labor Day, Thanksgiving Day, Christmas Day and Good Friday, provided the employee has at least 31 calendar days of service and works the last scheduled day before and the first scheduled day after the holiday, unless excused.

WELDERS - Receive rate prescribed for craft performing operation to which welding is incidental.
=====

Unlisted classifications needed for work not included within the scope of the classifications listed may be added after award only as provided in the labor standards contract clauses (29 CFR 5.5(a)(1)(ii)).

--

In the listing above, the "SU" designation means that rates listed under the identifier do not reflect collectively bargained wage and fringe benefit rates. Other designations indicate unions whose rates have been determined to be prevailing.

--

WAGE DETERMINATION APPEALS PROCESS

- 1.) Has there been an initial decision in he matter? This can be:
- * an existing published wage determination
 - * a survey underlying a wage determination
 - * a Wage and Hour Division letter setting forth a position on a wage determination matter
 - * a conformance (additional classification and rate) ruling

On survey related matters, initial contact, including requests for summaries of surveys, should be with the Wage and Hour Regional Office for the area in which the survey was conducted because those Regional Offices have responsibility for the Davis-Bacon survey program. If the

response from this initial contact is not satisfactory, then the process described in 2.) and 3.) should be followed.

With regard to any other matter not yet ripe for the formal process described here, initial contact should be with the Branch of Construction Wage Determinations. Write to:

Branch of Construction Wage Determinations
Wage and Hour Division
U.S. Department of Labor
200 Constitution Avenue, N.W.
Washington, DC 20210

2.) If the answer to the question in 1.) is yes, then an interested party (those affected by the action) can request review and reconsideration from the Wage and Hour Administrator (See 29 CFR Part 1.8 and 29 CFR Part 7). Write to:

Wage and Hour Administrator
U.S. Department of Labor
200 Constitution Avenue, N.W.
Washington, DC 20210

The request should be accompanied by a full statement of the interested party's position and by any information (wage payment data, project description, area practice material, etc.) that the requestor considers relevant to the issue.

3.) If the decision of the Administrator is not favorable, an interested party may appeal directly to the Administrative Review Board (formerly the Wage Appeals Board). Write to:

Administrative Review Board
U.S. Department of Labor
200 Constitution Avenue, N.W.
Washington, DC 20210

4.) All decisions by the Administrative Review Board are final.

END OF GENERAL DECISION

Project: Installation And Revision Of Traffic Control Signal In District III

3) Divers	37.57	20.29
4) Painters: (Bridge Construction) Brush, Roller, Blasting (Sand, Water, etc.), Spray	41.35	16.35
4a) Painters: Brush and Roller	29.17	16.35
4b) Painters: Spray Only	31.47	15.40
4c) Painters: Steel Only	30.47	15.40
4d) Painters: Blast and Spray	32.17	16.35
4e) Painters: Tanks, Tower and Swing	31.17	16.35
5) Electrician (Trade License required: E-1,2 L-5,6 C-5,6 T-1,2 L-1,2 V-1,2,7,8,9)	36.40	21.31

Project: Installation And Revision Of Traffic Control Signal In District III

6) Ironworkers: (Ornamental, Reinforcing, Structural, and Precast Concrete Erection	33.00	26.58 + a
---	-------	-----------

7) Plumbers (Trade License required: (P-1,2,6,7,8,9 J-1,2,3,4 SP-1,2) and Pipefitters (Including HVAC Work) (Trade License required: S-1,2,3,4,5,6,7,8 B-1,2,3,4 D-1,2,3,4 G-1, G-2, G-8, G-9)	38.67	24.46
--	-------	-------

----LABORERS---- - Last updated 4/27/11

8) Group 1: Laborer (Unskilled), Common or General, acetylene burner, concrete specialist	25.75	15.60
---	-------	-------

9) Group 2: Chain saw operators, fence and guard rail erectors, pneumatic tool operators, powdermen, air tool operator	26.00	15.60
--	-------	-------

10) Group 3: Pipelayers (Installation of water, storm drainage or sewage lines outside of the building line with P6, P7 license)	26.25	15.60
--	-------	-------

11) Group 4: Jackhammer/Pavement breaker (handheld); mason tenders (cement/concrete), catch basin builders, asphalt rakers, air track operators, block pavers and curb setters	26.25	15.60
--	-------	-------

12) Group 5: Toxic waste removal (non-mechanical systems)	27.75	15.60
---	-------	-------

Project: Installation And Revision Of Traffic Control Signal In District III

13) Group 6: Blasters	27.50	15.60
Group 7: Asbestos Removal, non-mechanical systems (does not include leaded joint pipe)	26.75	15.60
Group 8: Traffic control signalmen	16.00	15.60
----LABORERS (TUNNEL CONSTRUCTION, FREE AIR). Shield Drive and Liner Plate Tunnels in Free Air.---- Last updated 4/27/11----		
13a) Miners, Motormen, Mucking Machine Operators, Nozzle Men, Grout Men, Shaft & Tunnel Steel & Rodmen, Shield & Erector, Arm Operator, Cable Tenders	30.32	15.60 + a
13b) Brakemen, Trackmen	29.44	15.60 + a
----CLEANING, CONCRETE AND CAULKING TUNNEL----Last updated 4/27/11----		
14) Concrete Workers, Form Movers, and Strippers	29.44	15.60 + a

Project: Installation And Revision Of Traffic Control Signal In District III

15) Form Erectors	29.74	15.60 + a
-------------------	-------	-----------

----ROCK SHAFT LINING, CONCRETE, LINING OF SAME AND
TUNNEL IN FREE AIR:----Last updated 4/27/11----

16) Brakemen, Trackmen, Tunnel Laborers, Shaft Laborers	29.44	15.60 + a
---	-------	-----------

17) Laborers Topside, Cage Tenders, Bellman	29.33	15.60 + a
---	-------	-----------

18) Miners	30.32	15.60 + a
------------	-------	-----------

----TUNNELS, CAISSON AND CYLINDER WORK IN COMPRESSED
AIR: ----Last updated 4/27/11----

18a) Blaster	35.213	15.60 + a
--------------	--------	-----------

19) Brakemen, Trackmen, Groutman, Laborers, Outside Lock Tender, Gauge Tenders	35.036	15.60 + a
---	--------	-----------

Project: Installation And Revision Of Traffic Control Signal In District III

20) Change House Attendants, Powder Watchmen, Top on Iron Bolts	33.268	15.60 + a
---	--------	-----------

21) Mucking Machine Operator	35.745	15.60 + a
------------------------------	--------	-----------

----TRUCK DRIVERS----(*see note below)

Two axle trucks	27.88	15.71 + a
-----------------	-------	-----------

Three axle trucks; two axle ready mix	27.98	15.71 + a
---------------------------------------	-------	-----------

Three axle ready mix	28.03	15.71 + a
----------------------	-------	-----------

Four axle trucks, heavy duty trailer (up to 40 tons)	28.08	15.71 + a
--	-------	-----------

Four axle ready-mix	28.13	15.71 + a
---------------------	-------	-----------

Project: Installation And Revision Of Traffic Control Signal In District III

Heavy duty trailer (40 tons and over)	28.33	15.71 + a
Specialized earth moving equipment other than conventional type on-the road trucks and semi-trailer (including Euclids)	28.13	15.71 + a

----POWER EQUIPMENT OPERATORS----

Group 1: Crane handling or erecting structural steel or stone, hoisting engineer (2 drums or over), front end loader (7 cubic yards or over), Work Boat 26 ft. & Over. (Trade License Required)	35.05	19.40 + a
Group 2: Cranes (100 ton rate capacity and over); Backhoe/Excavator over 2 cubic yards; Piledriver (\$3.00 premium when operator controls hammer). (Trade License Required)	34.73	19.40 + a
Group 3: Excavator/Backhoe under 2 cubic yards; Cranes (under 100 ton rated capacity), Gradall; Master Mechanic; Hoisting Engineer (all types of equipment where a drum and cable are used to hoist or drag material regardless of motive power of operation), Rubber Tire Excavator (Drott-1085 or similar); Grader Operator; Bulldozer Fine Grade (slopes, shaping, laser or GPS, etc.). (Trade License Required)	33.99	19.40 + a
Group 4: Trenching Machines; Lighter Derrick; Concrete Finishing Machine; CMI Machine or Similar; Koehring Loader (Skooper)	33.60	19.40 + a
Group 5: Specialty Railroad Equipment; Asphalt Paver; Asphalt Spreader; Asphalt Reclaiming Machine; Line Grinder; Concrete Pumps; Drills with Self Contained Power Units; Boring Machine; Post Hole Digger; Auger; Pounder; Well Digger; Milling Machine (over 24" Mandrell)	33.01	19.40 + a

Project: Installation And Revision Of Traffic Control Signal In District III

Group 5 continued: Side Boom; Combination Hoe and Loader; Directional Driller.	33.01	19.40 + a
Group 6: Front End Loader (3 up to 7 cubic yards); Bulldozer (rough grade dozer).	32.70	19.40 + a
Group 7: Asphalt Roller; Concrete Saws and Cutters (ride on types); Vermeer Concrete Cutter; Stump Grinder; Scraper; Snooper; Skidder; Milling Machine (24" and Under Mandrel).	32.36	19.40 + a
Group 8: Mechanic, Grease Truck Operator, Hydroblaster, Barrier Mover, Power Stone Spreader; Welder; Work Boat under 26 ft.; Transfer Machine.	31.96	19.40 + a
Group 9: Front End Loader (under 3 cubic yards), Skid Steer Loader regardless of attachments (Bobcat or Similar); Fork Lift, Power Chipper; Landscape Equipment (including hydroseeder).	31.53	19.40 + a
Group 10: Vibratory Hammer, Ice Machine, Diesel and Air Hammer, etc.	29.49	19.40 + a
Group 11: Conveyor, Earth Roller; Power Pavement Breaker (whiphammer), Robot Demolition Equipment.	29.49	19.40 + a
Group 12: Wellpoint Operator.	29.43	19.40 + a

Project: Installation And Revision Of Traffic Control Signal In District III

Group 13: Compressor Battery Operator.	28.85	19.40 + a
Group 14: Elevator Operator; Tow Motor Operator (Solid Tire No Rough Terrain).	27.71	19.40 + a
Group 15: Generator Operator; Compressor Operator; Pump Operator; Welding Machine Operator; Heater Operator.	27.30	19.40 + a
Group 16: Maintenance Engineer/Oiler	26.65	19.40 + a
Group 17: Portable asphalt plant operator; portable crusher plant operator; portable concrete plant operator.	30.96	19.40 + a
Group 18: Power Safety Boat; Vacuum Truck; Zim Mixer; Sweeper; (minimum for any job requiring CDL license).	28.54	19.40 + a

**NOTE: SEE BELOW

----LINE CONSTRUCTION----(Railroad Construction and Maintenance)----Last updated 9/3/2010----

Project: Installation And Revision Of Traffic Control Signal In District III

20) Lineman, Cable Splicer, Dynamite Man 44.36 3% + 13.70

21) Heavy Equipment Operator 39.92 3% + 13.70

22) Equipment Operator, Tractor Trailer Driver, Material Men 37.71 3% + 13.70

23) Driver Groundmen 33.27 3% + 13.70

----LINE CONSTRUCTION----Last updated 4/17/09----

24) Driver Groundmen 30.92 6.5% + 9.70

25) Groundmen 22.67 6.5% + 6.20

26) Heavy Equipment Operators 37.10 6.5% + 10.70

Project: Installation And Revision Of Traffic Control Signal In District III

27) Linemen, Cable Splicers, Dynamite Men	41.22	6.5% + 12.20
28) Material Men, Tractor Trailer Drivers, Equipment Operators	35.04	6.5% + 10.45

Project: Installation And Revision Of Traffic Control Signal In District III

Welders: Rate for craft to which welding is incidental.

**Note: Hazardous waste removal work receives additional \$1.25 per hour for truck drivers.*

***Note: Hazardous waste premium \$3.00 per hour over classified rate*

- Crane with 150 ft. boom (including jib) - \$1.50 extra
- Crane with 200 ft. boom (including jib) - \$2.50 extra
- Crane with 250 ft. boom (including jib) - \$5.00 extra
- Crane with 300 ft. boom (including jib) - \$7.00 extra
- Crane with 400 ft. boom (including jib) - \$10.00 extra

All classifications that indicate a percentage of the fringe benefits must be calculated at the percentage rate times the "base hourly rate".

Apprentices duly registered under the Commissioner of Labor's regulations on "Work Training Standards for Apprenticeship and Training Programs" Section 31-51-d-1 to 12, are allowed to be paid the appropriate percentage of the prevailing journeymen hourly base and the full fringe benefit rate, providing the work site ratio shall not be less than one full-time journeyman instructing and supervising the work of each apprentice in a specific trade.

~~Connecticut General Statute Section 31-55a: Annual Adjustments to wage rates by contractors doing state work ~~

The Prevailing wage rates applicable to this project are subject to annual adjustments each July 1st for the duration of the project.

Each contractor shall pay the annual adjusted prevailing wage rate that is in effect each July 1st, as posted by the Department of Labor.

It is the contractor's responsibility to obtain the annual adjusted prevailing wage rate increases directly from the Department of Labor's website.

The annual adjustments will be posted on the Department of Labor's Web page: www.ct.gov/dol.

The Department of Labor will continue to issue the initial prevailing wage rate schedule to the Contracting Agency for the project.

All subsequent annual adjustments will be posted on our Web Site for contractor access.

As of: Thursday, September 15, 2011

Project: Installation And Revision Of Traffic Control Signal In District III

Effective October 1, 2005 - Public Act 05-50: any person performing the work of any mechanic, laborer, or worker shall be paid prevailing wage

All Person who perform work ON SITE must be paid prevailing wage for the appropriate mechanic, laborer, or worker classification.

All certified payrolls must list the hours worked and wages paid to All Persons who perform work ON SITE regardless of their ownership i.e.: (Owners, Corporate Officers, LLC Members, Independent Contractors, et. al)

Reporting and payment of wages is required regardless of any contractual relationship alleged to exist between the contractor and such person.

~~Unlisted classifications needed for work not included within the scope of the classifications listed may be added after award only as provided in the labor standards contract clause (29 CFR 5.5 (a) (1) (ii)).

Please direct any questions which you may have pertaining to classification of work and payment of prevailing wages to the Wage and Workplace Standards Division, telephone (860)263-6790.

CONNECTICUT DEPARTMENT OF LABOR
Wage and Workplace Standards Division

FOOTNOTES

Please Note: If the “Benefits” listed on the schedule for the following occupations includes a letter(s) (+ a or + a+b for instance), refer to the information below.

Benefits to be paid at the appropriate prevailing wage rate for the listed occupation.

If the “Benefits” section for the occupation lists only a dollar amount, disregard the information below.

Bricklayers, Cement Masons, Cement Finishers, Plasters, Stone Masons
(Building Construction)
(Residential- Hartford, Middlesex, New Haven, New London and Tolland Counties)

- a. Paid Holiday: Employees shall receive 4 hours for Christmas Eve holiday provided the employee works the regularly scheduled day before and after the holiday. Employers may schedule work on Christmas Eve and employees shall receive pay for actual hours worked in addition to holiday pay.

Bricklayer (Residential- Fairfield County)

- a. Paid Holiday: If an employee works on Christmas Eve until noon he shall be paid for 8 hours.

Electricians

Fairfield County: West of the Five Mile River in Norwalk

- a. \$2.00 per hour not to exceed \$14.00 per day.

Elevator Constructors: Mechanics

- a. Paid Holidays: New Year’s Day, Memorial Day, Independence Day, Labor Day, Thanksgiving Day, Christmas Day, plus the Friday after Thanksgiving.
- b. Vacation: Employer contributes 8% of basic hourly rate for 5 years or more of service or 6% of basic hourly rate for 6 months to 5 years of service as vacation pay credit.

Glaziers

- a. Paid Holidays: Labor Day and Christmas Day.

Power Equipment Operators

(Heavy and Highway Construction & Building Construction)

- a. Paid Holidays: New Year's Day, Good Friday, Memorial day, Independence Day, Labor Day, Thanksgiving Day and Christmas Day, provided the employee works 3 days during the week in which the holiday falls, if scheduled, and if scheduled, the working day before and the working day after the holiday. Holidays falling on Saturday may be observed on Saturday, or if the employer so elects, on the preceding Friday.

Ironworkers

- a. Paid Holiday: Labor Day provided employee has been on the payroll for the 5 consecutive workdays prior to Labor Day.

Laborers (Tunnel Construction)

- a. Paid Holidays: New Year's Day, Memorial Day, Independence Day, Labor Day, Thanksgiving Day and Christmas Day. No employee shall be eligible for holiday pay when he fails, without cause, to work the regular workday preceding the holiday or the regular workday following the holiday.

Roofers

- a. Paid Holidays: July 4th, Labor Day, and Christmas Day provided the employee is employed 15 days prior to the holiday.

Sprinkler Fitters

- a. Paid Holidays: Memorial Day, July 4th, Labor Day, Thanksgiving Day and Christmas Day, provided the employee has been in the employment of a contractor 20 working days prior to any such paid holiday.

Truck Drivers

(Heavy and Highway Construction & Building Construction)

- a. Paid Holidays: New Year's Day, Memorial Day, Independence Day, Labor Day, Thanksgiving Day, Christmas day, and Good Friday, provided the employee has at least 31 calendar days of service and works the last scheduled day before and the first scheduled day after the holiday, unless excused.

Revised: March 12, 2008

Informational Bulletin

Occupational Classifications

The Connecticut Department of Labor has the responsibility to properly determine "job classification" on prevailing wage projects covered under C.G.S. Section 31-53.

✓Note: This information is intended to provide a sample of some occupational classifications for guidance purposes only. It is not an all-inclusive list of each occupation's duties. This list is being provided only to highlight some areas where a contractor may be unclear regarding the proper classification.

On any construction project, an assortment of workers are needed to carry out all of the required tasks. Employees include various skilled crafts people, machine operators, general laborers, and apprentices. Prevailing wage rate schedules identify the classes of workers likely to be employed on each of the four types of construction projects. (If a contractor wants to use a class of worker not listed in a wage determination, there is a process for requesting the U.S. Department of Labor to establish a prevailing wage rate for that additional classification). (Contact U.S. Department of Labor at 202.693.0062 or 215.861.5800)

A registered apprentice is not a separate prevailing wage job classification. Apprentices are paid a percentage of the base rate received by the craft that they are training to become and the full fringe rate. This percentage increases in steps, as the apprentice advances through the stages of the apprenticeship process.

 Any questions regarding the proper classification should be directed to the Contract Compliance Unit, Wage and Workplace Standards Division, Connecticut Department of Labor, 200 Folly Brook Blvd, Wethersfield, CT 06109 at 860.263.6543.

Below are additional clarifications of specific job duties performed for certain classifications:

⇒ ASBESTOS WORKERS/INSULATORS:

- ▶ Handle, install, apply, fabricate, distribute, prepare, alter, repair, or dismantle heat and frost insulation, including penetration and fire stopping work on all penetration fire stop systems.

⇒ BOILERMAKERS:

- ▶ Erects hydro plants, incomplete vessels, steel stacks, storage tanks for water, fuel, etc. Builds incomplete boilers, repairs heat exchanges and steam generators.

⇒ BRICKLAYERS, CEMENT MASONS, CEMENT FINISHERS, MARBLE MASONS, PLASTERERS, STONE MASONS, PLASTERERS, STONE MASONS, TERRAZZO WORKERS, TILE SETTERS:

- ▶ Lays building materials such as brick, structural tile and concrete cinder, glass, gypsum, terra cotta block. Cuts, tools and sets marble, sets stone, finishes concrete, applies decorative steel, aluminum and plastic tile, applies cements, sand, pigment and marble chips to floors, stairways, etc.

⇒ CARPENTERS, MILLWRIGHTS, PILEDRIVERMEN, LATHERS, RESILIENT FLOOR LAYERS, DOCK BUILDERS, DIVERS, DIVER TENDERS:

- ▶ Constructs, erects, installs and repairs structures and fixtures of wood, plywood and wallboard. Installs, assembles, dismantles, moves industrial machinery. Drives piling into ground to provide foundations for structures such as buildings and bridges, retaining walls for earth embankments, such as cofferdams. Fastens wooden, metal or rockboard lath to walls, ceilings and partitions of buildings, acoustical tile layer, concrete form builder. Applies firestopping materials on fire resistive joint systems only. Installation of curtain/window walls only where attached to wood or metal studs.
- ▶ Assembly and installation of modular furniture/furniture systems.
[New] a. Free-standing furniture is not covered. This includes: student chairs, study top desks, book box desks, computer furniture, dictionary stand, atlas stand, wood shelving, two- position information access station, file cabinets, storage cabinets, tables, etc.

⇒ CLEANING LABORER:

- ▶ The clean up of any construction debris and the general cleaning, including sweeping, wash down, mopping, wiping of the construction facility, washing, polishing, dusting, etc., prior to the issuance of a certificate of occupancy falls under the *Labor classification*.

⇒DELIVERY PERSONNEL:

- ▶ If delivery of supplies/building materials is to one common point and stockpiled there, prevailing wages are not required. If the delivery personnel are involved in the distribution of the material to multiple locations within the construction site then they would have to be paid prevailing wages for the type of work performed: laborer, equipment operator, electrician, ironworker, plumber, etc.
- ▶ An example of this would be where delivery of drywall is made to a building and the delivery personnel distribute the drywall from one "stockpile" location to further sub-locations on each floor. Distribution of material around a construction site is the job of a laborer/tradesman and not a delivery personnel.

⇒ELECTRICIANS:

- ▶ Install, erect, maintenance, alteration or repair of any wire, cable, conduit, etc., which generates, transforms, transmits or uses electrical energy for light, heat, power or other purposes. ***License required per Connecticut General Statutes: E-1,2 L-5,6 C-5,6 T-1,2 L-1,2 V-1,2,7,8,9.**

⇒ELEVATOR CONSTRUCTORS:

- ▶ Install, erect, maintenance and repair of all types of elevators, escalators, dumb waiters and moving walks. ***License required by Connecticut General Statutes: R-1,2,5,6.**

⇒FORK LIFT OPERATOR:

- ▶ Laborers Group 4) Mason Tenders - operates forklift solely to assist a mason to a maximum height of nine (9) feet only.
- ▶ Power Equipment Operator Group 9 - operates forklift to assist any trade, and to assist a mason to a height over nine (9) feet.

⇒GLAZIERS: [updated]

- ▶ Installs light metal sash, head sills, and 2-story aluminum commercial storefronts.

⇒IRONWORKERS:

- ▶ Handling, sorting, and installation of reinforcing steel (rebar).
- ▶ Installation of aluminum window walls and curtain walls.
- ▶ Metal bridge rail (traffic), metal bridge handrail, and decorative security fence installation.
- ▶ Installation of handrails, stairs, and platforms installed on Wastewater Treatment Plant projects. [new]

⇒INSULATOR:

- ▶ Installing fire stopping systems/materials for "Penetration Firestop Systems": transit to cables, electrical conduits, insulated pipes, sprinkler pipe penetrations, ductwork behind radiation, electrical cable trays, fire rated pipe penetrations, natural polypropylene, HVAC ducts, plumbing bare metal, telephone and communication wires, and boiler room ceilings. Past practice using the applicable licensed trades, Plumber, Sheet Metal, Sprinkler Fitter, and Electrician, is not inconsistent with the Insulator classification and would be permitted.

⇒LEAD PAINT REMOVAL:

- ▶ Painter Rate -
 - 1) Removal of lead paint from bridges.
 - 2) Removal of lead paint as preparation of any surface to be repainted.
 - 3) Where removal is on a *Demolition* project prior to reconstruction.
- ▶ Laborer Rate-
 - 1) Removal of lead paint from any surface *NOT* to be repainted.
 - 2) Where removal is on a *TOTAL* Demolition project only.

⇒LABORERS:

- ▶ Acetylene burners, asphalt rakers, chain saw operators, concrete and power buggy operator, concrete saw operator, fence and guard rail erector, hand operated concrete vibrator operator, mason tenders, pipelayers (installation of water, storm drainage or sewage lines outside of the building line with P6, P7 license), pneumatic drill operator, pneumatic gas and electric drill operator, powermen and wagon drill operator, air track operator, block paver, curb setters, blasters, concrete spreaders.

⇒PAINTERS:

- ▶ Maintenance, preparation, cleaning, blasting (water and sand, etc.), painting or application of any protective coatings of every description on all bridges and appurtenances of highways, roadways, and railroads. Painting, decorating, hardwood finishing, paper hanging, sign writing, scenic art work and drywall finishing for any and all types of building and residential work.

⇒PLUMBERS AND PIPEFITTERS:

- ▶ Installation, repair, replacement, alteration or maintenance of all plumbing, heating, cooling and piping. ***License required per Connecticut General Statutes: P-1,2,6,7,8,9 J-1,2,3,4 SP-1,2. S-1,2,3,4,5,6,7,8 B-1,2,3,4 D-1,2,3,4.**

⇒POWER EQUIPMENT OPERATORS:

- ▶ Operates several types of power construction equipment such as compressors, pumps, hoists, derricks, cranes, shovels, tractors, scrapers or motor graders, etc. Repairs and maintains equipment. ***License required, crane operators only, per Connecticut General Statutes.**

⇒ROOFERS:

- ▶ Preparation of surface, tear-off and/or removal of any type of roofing, and/or clean-up of any areas where a roof is to be relaid.

⇒SHEET METAL WORKER:

- ▶ Fabrication, handling, assembling, erecting, altering, repairing, etc. of coated metal material panels and composite metal material panels when used on building exteriors and interiors as soffits, fascia, louvers, partitions, wall panel siding, canopies, cornice, column covers, awnings, beam covers, cladding, sun shades, lighting troughs, spires, ornamental roofing, metal ceilings, mansards, copings, ornamental and ventilation hoods, vertical and horizontal siding panels, trim, etc. The sheet metal classification also applies to the vast variety of coated metal material panels and composite metal material panels that have evolved over the years as an alternative to conventional ferrous and non-ferrous metals like steel, iron, tin, copper, brass, bronze, aluminum, etc. Insulated metal and insulated composite panels are still installed by the Iron Worker. Fabrication, handling, assembling, erecting, altering, repairing, etc. of architectural metal roof, standing seam roof, composite metal roof, metal and composite bathroom/toilet partitions, aluminum gutters, metal and composite lockers and shelving, kitchen equipment, and walk-in coolers.

⇒SPRINKLER FITTERS:

Installation, alteration, maintenance and repair of fire protection sprinkler systems. ***License required per Connecticut General Statutes: F-1,2,3,4.**

⇒TILE, MARBLE AND TERRAZZO FINISHERS:

Assists and tends the tile setter, marble mason and terrazzo worker in the performance of their duties.

⇒TRUCK DRIVERS:

- ▶ Truck Drivers delivering asphalt are covered under prevailing wage while on the site and directly involved in the paving operation.
- ▶ Material men and deliverymen are not covered under prevailing wage as long as they are not directly involved in the construction process. If, they unload the material, they would then be covered by prevailing wage for the classification they are performing work in: laborer, equipment operator, etc.
- ▶ Hauling material off site is not covered provided they are not dumping it at a location outlined above.
- ▶ Driving a truck on site and moving equipment or materials on site would be considered covered work, as this is part of the construction process.

Statute 31-55a

Last Updated: June 02, 2008

You are here: [DOL Web Site](#) ▶ [Wage and Workplace Issues](#) ▶ Statute 31-55a

- Special Notice -

To All State and Political Subdivisions, Their Agents, and Contractors

Connecticut General Statute 31-55a - Annual adjustments to wage rates by contractors doing state work.

Each contractor that is awarded a contract on or after October 1, 2002, for (1) the construction of a state highway or bridge that falls under the provisions of section 31-54 of the general statutes, or (2) the construction, remodeling, refinishing, refurbishing, rehabilitation, alteration or repair of any public works project that falls under the provisions of section 31-53 of the general statutes shall contact the Labor Commissioner on or before July first of each year, for the duration of such contract, to ascertain the prevailing rate of wages on an hourly basis and the amount of payment or contributions paid or payable on behalf of each mechanic, laborer or worker employed upon the work contracted to be done, and shall make any necessary adjustments to such prevailing rate of wages and such payment or contributions paid or payable on behalf of each such employee, effective each July first.

- The prevailing wage rates applicable to any contract or subcontract awarded on or after October 1, 2002 are subject to annual adjustments each July 1st for the duration of any project which was originally advertised for bids on or after October 1, 2002.
- Each contractor affected by the above requirement shall pay the annual adjusted prevailing wage rate that is in effect each July 1st, as posted by the Department of Labor.
- It is the *contractor's* responsibility to obtain the annual adjusted prevailing wage rate increases directly from the Department of Labor's Web Site. The annual adjustments will be posted on the Department of Labor Web page: www.ctdol.state.ct.us. For those without internet access, please contact the division listed below.
- The Department of Labor will continue to issue the initial prevailing wage rate schedule to the Contracting Agency for the project. All subsequent annual adjustments will be posted on our Web Site for contractor access.

Any questions should be directed to the Contract Compliance Unit, Wage and Workplace

Standards Division, Connecticut Department of Labor, 200 Folly Brook Blvd.,
Wethersfield, CT 06109 at (860)263-6790.

[Workplace Laws](#)

Published by the Connecticut Department of Labor, Project Management Office

November 29, 2006

Notice
To All Mason Contractors and Interested Parties
Regarding Construction Pursuant to Section 31-53 of the
Connecticut General Statutes (Prevailing Wage)

The Connecticut Labor Department Wage and Workplace Standards Division is empowered to enforce the prevailing wage rates on projects covered by the above referenced statute.

Over the past few years the Division has withheld enforcement of the rate in effect for workers who operate a forklift on a prevailing wage rate project due to a potential jurisdictional dispute.

The rate listed in the schedules and in our Occupational Bulletin (see enclosed) has been as follows:

Forklift Operator:

- **Laborers (Group 4) Mason Tenders** - operates forklift solely to assist a mason to a maximum height of nine feet only.
- **Power Equipment Operator (Group 9)** - operates forklift to assist any trade and to assist a mason to a height over nine feet.

The U.S. Labor Department conducted a survey of rates in Connecticut but it has not been published and the rate in effect remains as outlined in the above Occupational Bulletin.

Since this is a classification matter and not one of jurisdiction, effective January 1, 2007 the Connecticut Labor Department will enforce the rate on each schedule in accordance with our statutory authority.

Your cooperation in filing appropriate and accurate certified payrolls is appreciated.

Informational Bulletin

THE 10-HOUR OSHA CONSTRUCTION SAFETY AND HEALTH COURSE

(applicable to public building contracts entered into *on or after July 1, 2007*, where the total cost of all work to be performed is at least \$100,000)

- (1) This requirement was created by Public Act No. 06-175, which is codified in Section 31-53b of the Connecticut General Statutes (pertaining to the prevailing wage statutes);
- (2) The course is required for public building construction contracts (projects funded in whole or in part by the state or any political subdivision of the state) entered into on or after July 1, 2007;
- (3) It is required of private employees (not state or municipal employees) and apprentices who perform manual labor for a general contractor or subcontractor on a public building project where the total cost of all work to be performed is at least \$100,000;
- (4) The ten-hour construction course pertains to the ten-hour Outreach Course conducted in accordance with federal OSHA Training Institute standards, and, for telecommunications workers, a ten-hour training course conducted in accordance with federal OSHA standard, 29 CFR 1910.268;
- (5) The internet website for the federal OSHA Training Institute is http://www.osha.gov/fso/ote/training/edcenters/fact_sheet.html;
- (6) The statutory language leaves it to the contractor and its employees to determine who pays for the cost of the ten-hour Outreach Course;
- (7) Within 30 days of receiving a contract award, a general contractor must furnish proof to the Labor Commissioner that all employees and apprentices performing manual labor on the project will have completed such a course;
- (8) Proof of completion may be demonstrated through either: (a) the presentation of a *bona fide* student course completion card issued by the federal OSHA Training Institute; *or* (2) the presentation of documentation provided to an employee by a trainer certified by the Institute pending the actual issuance of the completion card;
- (9) Any card with an issuance date more than 5 years prior to the commencement date of the construction project shall not constitute proof of compliance;

- (10) Each employer shall affix a copy of the construction safety course completion card to the certified payroll submitted to the contracting agency in accordance with Conn. Gen. Stat. § 31-53(f) on which such employee's name first appears;
- (11) Any employee found to be in non-compliance shall be subject to removal from the worksite if such employee does not provide satisfactory proof of course completion to the Labor Commissioner by the fifteenth day after the date the employee is determined to be in noncompliance;
- (12) Any such employee who is determined to be in noncompliance may continue to work on a public building construction project for a maximum of fourteen consecutive calendar days while bringing his or her status into compliance;
- (13) The Labor Commissioner may make complaint to the prosecuting authorities regarding any employer or agent of the employer, or officer or agent of the corporation who files a false certified payroll with respect to the status of an employee who is performing manual labor on a public building construction project;
- (14) The statute provides the minimum standards required for the completion of a safety course by manual laborers on public construction contracts; any contractor can exceed these minimum requirements; and
- (15) Regulations clarifying the statute are currently in the regulatory process, and shall be posted on the CTDOL website as soon as they are adopted in final form.
- (16) Any questions regarding this statute may be directed to the Wage and Workplace Standards Division of the Connecticut Labor Department via the internet website of <http://www.ctdol.state.ct.us/wgwkstnd/wgemenu.htm>; or by telephone at (860)263-6790.

THE ABOVE INFORMATION IS PROVIDED EXCLUSIVELY AS AN EDUCATIONAL RESOURCE, AND IS NOT INTENDED AS A SUBSTITUTE FOR LEGAL INTERPRETATIONS WHICH MAY ULTIMATELY ARISE CONCERNING THE CONSTRUCTION OF THE STATUTE OR THE REGULATIONS.

Sec. 31-53b. Construction safety and health course. Proof of completion required for employees on public building projects. Enforcement. Regulations. (a) Each contract entered into on or after July 1, 2007, for the construction, remodeling, refinishing, refurbishing, rehabilitation, alteration or repair of any public building project by the state or any of its agents, or by an political subdivision of the state or any of its agents, where the total cost of all work to be performed by all contractors and subcontractors in connection with the contract is at least one hundred thousand dollars, shall contain a provision requiring that, not later than thirty days after the date such contract is awarded, each contractor furnish proof to the Labor Commissioner that all employees performing manual labor on or in such public building, pursuant to such contract, have completed a course of at least ten hours in duration in construction safety and health approved by the federal Occupational Safety and Health Administration or, in the case of telecommunications employees, have completed at least ten hours of training in accordance with 29 CFR 1910.268.

(b) Any employee required to complete a construction safety and health course required under subsection (a) of this section who has not completed the course shall be subject to removal from the worksite if the employee does not provide documentation of having completed such course by the fifteenth day after the date the employee is found to be in noncompliance. The Labor Commissioner or said commissioner's designee shall enforce this section.

(c) Not later than January 1, 2007, the Labor Commissioner shall adopt regulations, in accordance with the provisions of chapter 54, to implement the provisions of subsections (a) and (b) of this section. Such regulations shall require that the ten-hour construction safety and health courses required under subsection (a) of this section be conducted in accordance with federal Occupational Safety and Health Administration Training Institute standards, or in accordance with 29 CFR 1910.268, as appropriate. The Labor Commissioner shall accept as sufficient proof of compliance with the provisions of subsection (a) or (b) of this section a student course completion card issued by the federal Occupational Safety and Health Administration Training Institute, or such other proof of compliance said commissioner deems appropriate, dated no earlier than five years before the commencement date of such public works project.

(d) For the purposes of this section, "public building" means a structure, paid for in whole or in part with state funds, within a roof and within exterior walls or fire walls, designed for the housing, shelter, enclosure and support or employment of people, animals or property of any kind, including, but not limited to, sewage treatment plants and water treatment plants, "Public building" does not include site work, roads or bridges, rail lines, parking lots or underground water, sewer or drainage systems including pump houses or other utility systems.

